

**BAKER CENTER (CITY FILE #DR/PAR 20-02)**  
**TABLE OF CONTENTS**  
**(PLANNING COMMISSION MEETING 8-10-20)**

Title	Page No.
Staff Report	1
Attachment A – Land Use Application– Site and Design, Review, Type III	17
Attachment B – Land Use Application—Partition, Type III	18
Attachment C – Application Narrative and Criteria Responses	19
Attachment D – Preliminary Plat Map	99
Attachment E – Combined Plan Set	100
Attachment F – Pre-Application Conference Minutes	114
Attachment G – Neighborhood Meeting Minutes	122
Attachment H – Draft Transportation Impact Analysis (TIA)	125
Attachment I – Public and Agency Comments	257
Baker Center Final Findings	266

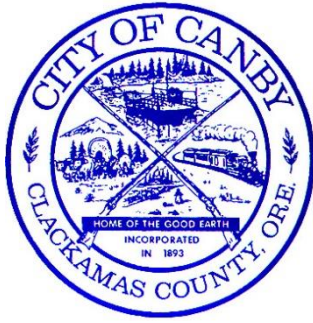

# City of Canby

## Staff Report File #: DR 20-02 / PAR 20-02 – Baker Center

**HEARING DATE:** August 10, 2020

**STAFF REPORT DATE:** July 31, 2020

**TO:** Planning Commission

**STAFF:** Ryan Potter, AICP, Senior Planner

### Applicant Request

The applicant is seeking Planning Commission approval to partition a 20.2-acre property into three parcels (City File PAR 20-02) and construct three speculative light industrial buildings ranging from 46,800 to 210,600 square feet (City File DR 20-02). Each building would be located on its own parcel but the development would share a vehicular circulation system that connects the buildings' respective parking areas.

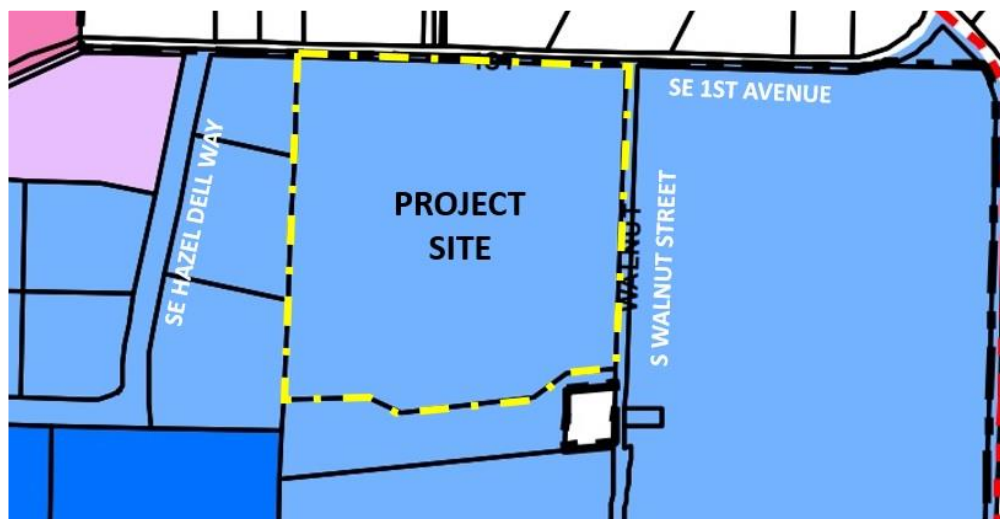

### Staff Recommendation

Based on the application submitted and the facts, findings, and conclusions of this report, staff recommends **Approval** of DR 20-02 and PAR 20-02 pursuant to the Conditions of Approval identified in Section V of this Staff Report.

### **Property/Owner Information**

**Location:** SE 1st Avenue between SE Hazel Dell Way and S Walnut Road  
**Tax Lots:** 31E34 00300  
**Property Size:** 20.21 acres  
**Comprehensive Plan:** LI – Light Industrial  
**Current Zoning:** M-1 – Light Industrial; I-O – Canby Industrial Area Overlay Zone  
**Owner:** TC/EIL Baker, LLC  
**Applicant:** VLMK Engineering + Design  
**Application Type:** Site and Design Review (Type III); Partition (Type III)  
**City File Numbers:** DR 19-02; PAR 20-02

### **Attachments**

- A. Land Use Application – Site and Design Review, Type III
- B. Land Use Application – Partition, Type III
- C. Application Narrative and Criteria Responses
- D. Preliminary Plat Map
- E. Combined Plan Set
- F. Pre-Application Conference Minutes
- G. Neighborhood Meeting Minutes
- H. Draft Transportation Impact Analysis (TIA)
- I. Public and Agency Comments

### **Existing Conditions**

The 20.21-acre project site is located at the corner of SE 1st Avenue and S Walnut Street in the Canby Pioneer Industrial Park. SE Hazel Dell Way is located to the west but is not directly adjacent to the subject property. The subject property is currently used for agricultural purposes; is devoid of buildings or structures; and is largely flat. It is zoned M-1, Light Industrial; is within the Canby Industrial Park Area Overlay (I-O) zone; and is designated for Light Industrial (LI) uses in the City of Canby Comprehensive Plan.

Surrounding parcels are similarly zoned M-1 but feature a mix of vacant land and industrial, residential, and agricultural uses. Across SE 1st Avenue to the north are rural residential uses in the unincorporated County (i.e., outside the City Limits); across S Walnut Road to the east is the Columbia Distributing, a 530,000-square-foot beverage distribution facility and warehouse that is nearing completion. To the immediate south is Zoar Lutheran Cemetery (an unincorporated island parcel with the City) and a light industrial property largely used for outdoor storage of vehicles and materials. To the west are manufacturing uses in concrete “tilt-up” buildings, and a vacant property adjacent to SE 1st Avenue. Elsewhere in the nearby vicinity are large light industrial uses that have been recently completed, recently approved, or are under construction.

### **Project Overview**

The proposed project would involve the construction and operation of a speculative development intended to accommodate a combination of warehouse and light manufacturing tenants. Phasing of the three-building development would be initiated with infrastructure improvements and street frontage improvements along SE 1<sup>st</sup> Avenue and S Walnut Street. This would be followed by the development of one or more of the three buildings. The project applicant anticipates that buildout of the development would occur within five years.

In order to better facilitate the phased approach to the site’s development and occupation by multiple tenants, the proposed project also includes the subject property’s partition into three separate parcels. The table below summarizes the proposed parcels and buildings. Note that the difference between the total acreage quoted above and that in the table below is due to right-of-way dedication along the adjacent roadways.

Parcel	Parcel Area		Building	Building Area (Square Feet)	# of Suites
	Square Feet	Acres			
1	150,435	3.45	A	46,800	2
2	228,664	5.25	B	75,600	2
3	487,482	11.19	C	210,600	4
<b>Total</b>	<b>866,581</b>	<b>19.89</b>	<b>N/A</b>	<b>333,000</b>	<b>8</b>

The three proposed buildings would have ancillary office space for each tenant space and would have loading berths on the entirety of their west-facing elevations. The proposed buildings would be of concrete “tilt-up” construction similar to those in nearby developments in the Canby Pioneer Industrial Park. Parking would be arranged the perimeter of the project site, with parking areas located on each of the three proposed parcels.

**Analysis and Findings**

**I. Applicable Criteria**

Applicable criteria used in evaluating this application are listed in the following sections of the City of Canby’s *Land Development and Planning Ordinance*:

- 16.08: General Provisions
- 16.10: Off-street Parking and Loading
- 16.32: M-1 – Light Industrial Zone
- 16.35: Canby Industrial Area Overlay (I-O) Zone
- 16.42: Signs
- 16.43: Outdoor Lighting Standards
- 16.46: Access Limitations on Project Density
- 16.49: Site and Design Review
- 16.60: Partitions
- 16.86: Street Alignments
- 16.89: Application and Review Procedures
- 16.120: Parks, Open Space, and Recreational Land

**II. Facts and Findings**

The following analysis evaluates the proposed project’s conformance with applicable approval criteria and other municipal code sections, as listed above in Section I. Due to their importance in the assessment of large development projects, Site and Design Review Criteria are analyzed first. Additional applicable sections of the Canby Municipal Code are then analyzed in the order that they appear in the code.



## **A. Site and Design Review Criteria (Municipal Code Section 16.49)**

Section 16.49 of the Zoning Code provides review criteria to be used in the design review process. Note that some portions of this section are superseded by provisions of the Municipal Code tailored specifically to the Canby Pioneer Industrial Park (as noted in this Staff Report).

In review of a Type III Site and Design Review Application, the Board shall, in exercising or performing its powers, duties or functions, determine whether there is compliance with the following:

1. The proposed site development, including the site plan, architecture, landscaping and graphic design, is in conformance with the standards of this and other applicable city ordinances insofar as the location, height and appearance of the proposed development are involved; and
2. The proposed design of the development is compatible with the design of other developments in the same general vicinity; and
3. The location, design, size, color and materials of the exterior of all structures and signs are compatible with the proposed development and appropriate to the design character of other structures in the same vicinity.
4. The proposed development incorporates the use of LID best management practices whenever feasible based on site and soil conditions. LID best management practices include, but are not limited to, minimizing impervious surfaces, designing on-site LID stormwater management facilities, and retaining native vegetation.
5. The Board shall, in making its determination of compliance with this Ordinance, shall use the matrix in Table 16.49.040 to determine compatibility unless this matrix is superseded by another matrix applicable to a specific zone or zones under this title. An application is considered to be compatible with the standards of Table 16.49.040 if the following conditions are met: a. The development accumulates a minimum of 60 percent of the total possible number of points from the list of design criteria in Table 16.49.040; and b. At least 10 percent of the points used to comply with (a) above must be from the list of LID Elements in Table 16.49.040.
6. Street lights installation may be required on any public street or roadway as part of the Design Review Application.

City Staff finds that the proposed project, including its site plan, architecture, and landscaping, is compatible with the surrounding context of the project site, which is an industrial park intended for light industrial uses such as warehousing and light manufacturing uses. Accordingly, the area is planned to accommodate large buildings and businesses. While the size, height, and bulk of the proposed building would represent a substantial change from the existing visual character on the project site—which is currently vacant—this change is anticipated by the Canby Comprehensive Plan and applicable Concept Plan.

The proposed project features an onsite storm water system consisting of dry wells and detention vaults. Most of the LID best management practices listed above (e.g., minimizing impervious surfaces and retaining native vegetation) are not feasible due to the nature of the proposed project (a large-scale light industrial facility requiring large maneuvering areas for delivery trucks) and the site's existing conditions (lacking native vegetation). However, impervious surfaces have been minimized to the extent feasible.

*Finding 1:* For the above reasons, Planning Staff finds this request is consistent with applicable provisions of the Canby Municipal Code.

Other subsections of Section 16.49:

- **Site Design Review Matrix.** The site and design review matrix provided in Subsection 16.49.040 applies to most locations in the City but is superseded by a more specific matrix for projects in the I-O Overlay Zone (Canby Pioneer Industrial Park). For an analysis of the proposed project’s achievement of criteria in this matrix, see “Section 16.35: Canby Industrial Area Overlay (I-O) Zone”, below.
- **Bicycle and Pedestrian Facilities.** The submitted materials generally demonstrate compliance with standards related to pedestrian facilities. To the extent feasible, the proposed internal walkway system facilitates connections to the surrounding area. Sidewalks link the main entrances of Buildings A and B directly to the public sidewalks along S Walnut Street and SE 1st Avenue. Sidewalks on the western portion of the site would link main entrances of Building C to the public sidewalk along SE 1<sup>st</sup> Avenue. Note that these sidewalk connections cross drive aisles in several locations but are separated from vehicular circulation as much as feasible.

Submitted design drawings for the proposed project do not identify bicycle parking, provision of which is required by the Canby Municipal Code. Section V of this Staff Report includes a condition of approval requiring that the project design be modified to include bicycle parking as required.

- **Landscaping.** The submitted materials, including the Landscaping Calculation Form in Attachment C to this Staff Report, generally demonstrate general compliance with City landscaping standards. The project site is required to have a minimum of 15 percent landscaped area (130,008 square feet<sup>1</sup>) and the proposed project provides 130,522 square feet. As identified in the code, landscaping and exterior improvements shall be completed prior to issuance of certificates of occupancy.

As shown in the submitted Landscape Plan, the proposed project would have layered landscaping along its two street frontages, include street trees in the planter strip and a combination of trees, bushes, and other plantings between the sidewalk and parking areas. This is consistent with Subsection 16.49.120 (G) of the Municipal Code, which states that “screening of parking and loading areas is required.”

Subsection 16.49.120 (E) requires all parking areas with more than 16 spaces shall include landscaping islands to “break up the parking area into rows of not more than 8 contiguous parking spaces.” This requirement is not met by the proposed project, which includes rows containing 9 to 12 spaces. Section V of this Staff Report includes a condition of approval requiring that the project design be modified to comply with this standard.

---

<sup>1</sup> Note that Row 8 in the Landscape Calculation Form provided by the applicant should identify a requirement of 130,008 square feet.

*Finding 2:* For the above reasons, Planning Staff finds this request, as conditioned, is consistent with applicable provisions of the Canby Municipal Code to the extent feasible.

## **B. Other Applicable Code Sections**

Below are additional sections of the Canby Municipal Code that apply to the proposed project.

### **Section 16.08.070: *Illegally Created Lots***

In no case shall a lot created in violation of state statute or City ordinance be considered as a lot of record for development purposes, until such violation has been legally remedied. The project applicant has submitted documentation that identifies the project site (Tax Lot 31E34 00300) as a legally created lot this is eligible for partition and development.

*Finding 3:* For the above reasons, Planning Staff finds this request is consistent with applicable provisions of the Canby Municipal Code.

### **Section 16.08.150: *Traffic Impact Study***

A Transportation Impact Analysis (TIA) was prepared for the proposed project by DKS Associates in April 2020. Using existing traffic data and projections for the generation of new vehicle trips by the proposed project, the TIA analyzes impacts of the proposed project on the area's circulation network, including roadways and intersections. The report's methodology and assumptions are identified in the TIA, which is attached to this Staff Report as an attachment.

The TIA projects that the proposed project would generate 132 AM peak hour trips, 144 PM peak hour trips, and 949 overall daily vehicle trips. These estimates are based on trip generation rates for Manufacturing and Warehousing uses. As shown in Table 4 of the TIA, approximately 19 percent of these 949 daily trips (179 trips) would be truck trips.

As shown in Tables 6 and 7 in the TIA, under the 2022 With Project scenario, the vehicle trips generated by the proposed project and surrounding development are not anticipated to trigger unacceptable levels of service or volume/capacity ratios at the studied intersections. The intersection of Highway 99E at Haines Road would operate at an unacceptable level as it would under a 2022 No Project scenario; no additional intersections fail to meet mobility standards when compared to 2022 background conditions.

As shown in Tables 6 and 7 in the TIA, the re-routed traffic associated with the planned extension of S Walnut Street to Highway 99E is expected to have little impact on intersection operations when compared to a scenario without that segment.

Because the TIA for the proposed project was prepared prior to land use approval of the nearby Caruso Produce and Stanton Furniture projects, these large developments are not included in those counted as generating "background traffic" in the 2022 scenarios contemplated by the TIA (see Page 16 of the TIA for a list of developments used in the analysis). However, the traffic consultant (DKS) has advised Planning Staff that these projects, when combined with the proposed project, would not be expected to trigger new unacceptable impacts at area intersections.

To test this, the traffic consultant conducted rough calculations adding trips generated by the proposed project to those analyzed in the recent TIA for the Redwood Landing II project, which included Caruso Produce and Stanton Furniture as background projects.

This resulted in only an approximately 2 percent increase in trips traveling through the Highway 99E/N Redwood/Sequoia Parkway intersection, which would be the intersection most impacted by the combined operation of the four development projects (Baker Center, Caruso Produce, Stanton Furniture, and Redwood Landing II). Other nearby intersections would be expected to see smaller fluctuations in overall traffic.

*Finding 4:* For the above reasons, Planning Staff finds this request is consistent with applicable provisions of the Canby Municipal Code.

#### **Section 16.08.160: Safety and Functionality Standards**

The City will not issue any development permits unless the proposed development complies with the City's basic transportation safety and functionality standards, the purpose of which is to ensure that development does not occur in areas where the surrounding public facilities are inadequate. At the time of development permit application submittal, the applicant shall demonstrate that the property has or will have the following:

- A. Adequate street drainage;
- B. Provides safe access and clear vision at intersections;
- C. Public utilities are available and adequate to serve the project;
- D. Access onto a public street with the minimum paved widths as stated in Subsection E below.
- E. Adequate frontage improvements as follows:
  - b. For collector and arterial streets, a minimum paved width of 20 feet along the site's frontage.
- F. Compliance with mobility standards identified in the TSP. If a mobility deficiency already exists, the development shall not create further deficiencies. (Ord 1340, 2011)

The adequacy of public utilities and future public improvements to serve the proposed project was discussed at the pre-application conference held on July 9, 2019. While electrical, water, and sanitary sewer service are capable of serving the project site, street improvements and extensions of infrastructure would be required. Water and wastewater infrastructure to serve the proposed project would be extended in SE 1<sup>st</sup> Avenue along the project site's northern frontage.

As detailed in the conditions of approval provided by the City Engineer (see Section V of this Staff Report), half-street and frontage improvements would be required on SE 1<sup>st</sup> Avenue and S Walnut Street consistent with existing improvements to those roadways and their designated street classifications. With these improvements, circulation to, from, and in the general vicinity of the project site would be consistent with the City's TSP. As discussed above under the response to code Subsection 16.08.150, traffic generated by the proposed project would not "create further deficiencies" where existing deficiencies exist.

*Finding 5:* For the above reasons, Planning Staff finds this request, as conditioned, is consistent with applicable provisions of the Canby Municipal Code.

#### **Section 16.10: Off-Street Parking and Loading**

As identified in Section 16.10.050 of the Municipal Code, both warehousing and manufacturing uses are required to provide the following off-street parking spaces: two

spaces per 1,000 gross square feet of office space plus one space per 1,000 gross square feet of non-office space.

The table below demonstrates that the 392 proposed parking spaces meet the 354 total spaces required by the code. Note that Parcels 1 and 3 have more spaces than required, while Parcel 2 is deficient by two spaces. Because the overall project site is designed to function as one development, Staff concludes that the provided parking is sufficient to serve the development.

	Parcel	Proposed Square Feet	Development Standard	Required Spaces	Provided Spaces
1	Office	3,000	2 spaces/1,000 square feet	6	73
	Manufacturing/Warehousing	43,800	1 space/1,000 square feet	44	
	Total	46,800	N/A	50	
2	Office	5,428	2 spaces/1,000 square feet	11	79 <sup>2</sup>
	Manufacturing/Warehousing	70,172	1 space/1,000 square feet	70	
	Total	75,600	N/A	81	
3	Office	11,880	2 spaces/1,000 square feet	24	240
	Manufacturing/Warehousing	198,720	1 space/1,000 square feet	199	
	Total	210,600	N/A	223	
<b>Grand Total</b>		<b>333,000</b>	<b>N/A</b>	<b>354</b>	<b>392<sup>3</sup></b>

The development’s proposed number of loading berths (84)<sup>4</sup> is well above that required for industrial uses of 60,000 or more square feet (a minimum of three). Subsection 16.10.060 requires that loading facilities be screen from “public view, from public streets, and adjacent properties.” Loading berths in Buildings A and B would face the interior of the site. Loading berths in Building C would face the rear of adjacent properties to the west. However, these would be screened by fencing, landscaping, and trees; they would also be set back over a hundred feet from the western property boundary.

As discussed on Page 5 of this Staff Report, the surface parking proposed for the project site will be required to be reconfigured in order to provide additional landscaped islands as required by the Canby Municipal Code. This may affect the project’s overall parking count. However, because the project design currently has substantially more parking than required, this reconfiguration is not expected to result in an overall deficiency in parking. Final site plans for the proposed project shall demonstrate this compliance.

<sup>2</sup> Parcel 2 also provides a grouping of 14 tandem (stacked) truck parking spaces.

<sup>3</sup> Calculated by Staff. This total differs from the total number of spaces identified by the applicant, which is 407 spaces.

<sup>4</sup> Calculated by Staff. This total differs from the applicant’s narrative, which states 87 total berths.

For industrial park uses, Subsection 16.10.100 of the Canby Municipal Code requires a minimum of two bicycle parking spaces per development, or 0.1 space per 1,000 square feet, whichever is greater. The proposed project therefore requires 33 bicycle parking spaces, which must be "...within fifty (50) feet of the main entrance to a building." Bicycle parking is not currently shown on the site plan for the proposed project. Section V of this Staff Report includes a condition of approval requiring that bicycle parking be provided as required.

*Finding 6:* For the above reasons, Planning Staff finds this request, as conditioned, is consistent with applicable provisions of the Canby Municipal Code.

### **Section 16.32: M-1 Light Industrial Zone**

As listed in Section 16.32.010 of the Canby Municipal Code, uses permitted outright in the M-1 Zone include a broad range of manufacturing, processing, distribution, and storage uses. Because the proposed project is a speculative development, the exact number and types of tenants that would occupy the three buildings is unknown.

However, the building typology proposed (large, open-plan, concrete tilt-up light industrial spaces with loading docks) is consistent with the land uses envisioned for the M-1 Zone and would accommodate the types of businesses found elsewhere in the Canby Pioneer Industrial Park. Future tenants would be subject to the provisions of the code related to permitted and prohibited land uses. Existing City and County review processes, including business license approvals, site plan release letters for tenant improvements, and certificate of occupancy approvals, would ensure that individual uses proposed to do business in the development are allowed in the M-1 Zone.

Furthermore, the proposed project is consistent with the development standards required of land uses in the M-1 Zone. Its lot area is well above 5,000 square feet (19.89 acres after ROW dedication) and its maximum height is below 45 feet tall (the tallest building is Building C at 41 feet). The M-1 Zone has no maximum lot coverage requirement and no interior or rear yard requirement when the parcel is not adjacent to a residential zone.

*Finding 7:* For the above reasons, Planning Staff finds this request is consistent with applicable provisions of the Canby Municipal Code.

### **Section 16.35: Canby Industrial Area Overlay (I-O) Zone**

The Industrial Area Overlay allows land uses which are permitted by the underlying zone districts. As indicated above, the proposed partition is consistent with the range of land uses permitted in the M-1 Zone. The I-O Zone has no minimum lot area or minimum lot width/frontage requirements.

The proposed building is shorter than the maximum height of 45 feet, as identified in Section 16.35. As required, the building also provides "one public entrance facing the street." This is achieved by five tenant office entrances facing the public realm: one facing SE 1<sup>st</sup> Avenue on Building C and four office entrances facing S Walnut Street on Buildings A and B). All of these have a "direct pedestrian connection" between the building entrance and the public sidewalk. While three offices in Building C do not directly face the public realm, they are linked to SE 1<sup>st</sup> Avenue by the project site's pedestrian circulation system. Staff notes that based on the proposed building typology (very large rectilinear buildings punctuated by large rows of loading berths), building entrances face the public realm to the extent feasible.



The proposed building would be of concrete tilt-up construction, which is consistent with the overlay zone's prohibition of metal building exteriors.

Section 16.35 provides a design review matrix specific to the I-0 Zone that substitutes for the matrix used for projects elsewhere in the City. Projects must meet the minimum acceptable score unless Planning Staff determines that certain provisions do not apply. The applicant's self-assessment of consistency with the design review matrix indicates that the project meets most minimum scores per category except for "Parking."

- **Parking:** Staff finds that because roughly half of the parking is "located to the side or rear of buildings as viewed from the public right-of-way" and because consolidating a greater proportion of the project's parking at the rear of the site would move handicapped spaces too far from main office entrances, the project earns one point on the first parking-related matrix criterion.
- **Transportation/Circulation:** Staff concurs with the project applicant's assessment in this area.
- **Landscaping:** The project applicant's submittal materials do not demonstrate that the project provides an outdoor amenity such as "water features, plazas, seating areas, and similar features" that is for general public use. However, a loss of one point under this criterion does not result in a score that is below the acceptable minimum.
- **Building Appearance and Orientation:** Although the proposed buildings do not provide physical articulation via building massing, their elevations utilize panel articulation, storefront glazing, façade materials, paint, and recessed entries to accentuate building entrances. Therefore, Staff concurs with the project applicant's assessment of this criterion.

*Finding 8:* For the above reasons, Planning Staff finds this request is consistent with applicable provisions of the Canby Municipal Code.

#### **Section 16.42: Signs**

Although the proposed facility would have signage, no signs are proposed at this time and approval of the proposed land use does not extend to building numbering conceptually shown on the applicant's submitted materials. Chapter 16.42, *Signage*, of the Municipal Code identifies requirements that will apply to signs proposed for the project at a future date.

*Finding 9:* For the above reasons, Planning Staff finds this request is consistent with applicable provisions of the Canby Municipal Code.

#### **Section 16.43: Outdoor Lighting Standards**

Because of its location in the Pioneer Industrial Park and its M-1 zoning, the project site is designated Lighting Zone 2 (LZ 2) by the Municipal Code. The code identifies requirements related to the placement, shielding, height, and intensity of light of outdoor light fixtures. As shown in the applicant's submittal materials, the proposed project would include outdoor lighting affixed to the proposed building, 14 pole-mounted lighting fixtures illuminating the parking and internal circulation areas, and nine pole-mounted street lights along the site's two street frontages.

As currently proposed, Staff does not anticipate a lack of compliance with City lighting standards. The provided photometric plan demonstrates that light overspill onto surrounding properties is minimal (between 0 and 1 foot candles). Furthermore,

landscaping has been designed to minimize glare from headlights onto the site from surrounding streets and vice-versa. However, prior to site plan approval, the project applicant will be required to submit a lighting plan to the City of Canby consistent with Section 16.43.110 of the Municipal Code. Section V of this Staff Report includes a condition of approval requiring that a more comprehensive lighting plan to be submitted showing how the proposed light fixtures and luminaires meet the requirements (e.g., shielding) of this section.

*Finding 10:* For the above reasons, Planning Staff finds this request, as conditioned, is consistent with applicable provisions of the Canby Municipal Code.

#### **Section 16.46: Access Limitations on Project Density**

Section 16.46.040 of the Municipal Code addresses the spacing of accesses onto public streets. For collector streets such as SE 1<sup>st</sup> Avenue, the minimum required spacing between roadways and driveways, and between two driveways, is 100 feet (measured centerline to centerline; see Table 16.46.030). The spacing between the driveways proposed for the proposed project are well above these minimums. Note that the I-O Overlay Zone, applicable to the project site, identifies a more restrictive standard of 200-foot spacing for collector roadways. This standard is also met by the proposed project. Because Walnut Street is designated as a local street, lesser spacing distances (50 feet between roadways and driveways; 10 feet between driveways) are required and would be met by the proposed project.

*Finding 11:* For the above reasons, Planning Staff finds this request is consistent with applicable provisions of the Canby Municipal Code.

#### **Section 16.60: Partitions**

The proposed partition is consistent with the definition of “partition” found in Section 16.04.470 of the Canby Land Development and Planning Ordinance, as it would divide the subject property into “two or three parcels.” Section 16.60.030, *Partitions*, of the Canby Municipal Code state that an application for a partition shall be evaluated upon the following standards and criteria:

##### **A. Conformance with the text and applicable maps of the comprehensive plan.**

The adopted City of Canby Comprehensive Plan designates the subject property and surrounding parcels for Light Industrial (LI) uses. The proposed partition does not involve rezoning or re-designation of the property; therefore the general vicinity’s concentration of industrial land would remain intact, consistent with the Comprehensive Plan’s intention for the area to function as an industrial park. The proposed partition has been designed to facilitate development of the proposed lots with light industrial uses in the near future and the proposed lot dimensions are sufficiently large to allow a variety of light industrial uses.

##### **B. Conformance with all other applicable requirements of the Land Development and Planning Ordinance.**

Because the proposed project involves Site and Design Review in addition to a land partition, the proposed project has been analyzed for consistency with other applicable requirements of the Canby Municipal Code, including Sections 16.08, 16.10, 16.32, 16.35, 16.42, 16.43, 16.46, 16.49, 16.86, 16.89, and 16.120. This analysis is found above and below within this Staff Report.



**C. The overall design and arrangement of parcels shall be functional and shall adequately provide building sites, utility easements, and access facilities deemed necessary for the development of the subject property without unduly hindering the use or development of adjacent properties.**

As discussed above, the three proposed parcels are sufficiently large enough to accommodate a wide range of land uses consistent with the M-1 Light Industrial Zone. The surrounding parcels, while currently featuring a mix of land uses and vacant lands, are intended by the City's Comprehensive Plan and Pioneer Industrial Park Master Plan to function as an industrial park. Therefore, partition of the subject property in preparation for development with industrial development would not hinder use or development of adjacent properties. All three parcels would front onto public streets and would have access to public utilities. Although a small cemetery is located to the immediate south of the subject property, operation of the proposed project would not prevent continued operation of the cemetery.

Staff finds that the overall design and arrangement of the proposed parcels would function adequately without unduly hindering the development or use of adjacent properties. Therefore, staff finds this criterion has been met.

**D. No partitioning shall be allowed where the sole means of access is by private road, unless it is found that adequate assurance has been provided for year-round maintenance sufficient to allow for unhindered use by emergency vehicles, and unless it is found that the construction of a street to City standards is not necessary to insure safe and efficient access to the parcels.**

The three proposed parcels would all be accessed by public streets: Parcel 1 would front SE 1<sup>st</sup> Avenue and S Walnut Street; Parcel 2 would front on S Walnut Street; and Parcel 3 would front SE 1<sup>st</sup> Avenue. Overall, there would be four vehicular access points from the subject property to public streets. Therefore this criterion has been met.

**E. It must be demonstrated that all required public facilities and services are available or will become available through the development, to adequately meet the needs of the proposed land division.**

At the pre-application meeting held on July 9, 2019, the subject property's access to public services and utilities was discussed. While electrical, water, and sewer service are capable of serving the proposed parcels, improvements and extensions of infrastructure would be required, as conditioned in Section V of this Staff Report.

The project applicant shall work with Canby Utility and the Canby Public Works Department in order to provide the appropriate connections to all required utilities as well as demonstrate final utility easement placement, prior to final map recordation. Therefore, as conditioned, this criteria has been met.

*Finding 12:* For the above reasons, Planning Staff finds this request, as conditioned, is consistent with applicable provisions of the Canby Municipal Code.

**Section 16.86: Street Alignments**

This section of the zoning code requires that adequate space be provided for the planned expansion, extension, or realignment of public streets consistent with Canby's TSP. Because the project site fronts and gains access from two existing roadways (SE 1<sup>st</sup> Avenue and S Walnut Street), half-street improvements to these roadways are

required. Section V of this Staff Report lists conditions of approval provided by the Canby City Engineer that identify street improvements required to expand the two streets to their desired final street section.

The intersection of the two aforementioned streets is the current terminus of S Walnut Street, which is planned to be extended from that location to Highway 99E. Although the future extension of S Walnut Street (and a turnabout to aid S Walnut Street's transition from a local street section to an industrial collector street) is a standalone project not contingent on the proposed project, some right-of-way dedication at the intersection of SE 1<sup>st</sup> and S Walnut Street will be required. Section V of this Staff Report identifies a condition of approval related to this requirement, which likely requires modifications to the northeastern corner of the proposed project's final design.

*Finding 13:* For the above reasons, Planning Staff finds this request, as conditioned, is consistent with applicable provisions of the Canby Municipal Code.

### **Section 16.120: Parks, Open Space, and Recreational Land**

This section of the Canby Municipal Code requires dedication of parkland or payment of system development charges (SDCs) to compensate for the increased demand for recreational amenities generated by new land uses. The proposed project does not dedicate public park space; if approved, the City will provide the applicant with an itemized summary of applicable SDCs.

*Finding 14:* For the above reasons, Planning Staff finds this request is consistent with applicable provisions of the Canby Municipal Code.

## **III. Public and Agency Comments**

Notice of this application and the opportunity to provide comment was forwarded to property owners and residents within a 500-foot radius and to applicable public agencies. At the time of this writing, one public comment and two agency comments were received:

### **A. Public Comments**

1. **Steve B. Morgan of Zoar Lutheran Church, dated July 27, 2020.** A representative from the entity who owns and manages the small cemetery directly south of the project site (Zoar Cemetery) submitted comments regarding its adjacency to the proposed project. The commenter expressed concerns about construction impacts, smoking near the cemetery, impacts to trees, and the possible presence of gravesites outside the cemetery property.

Section V of this Staff Report includes a condition of approval related to the discovery of gravesites or human remains on the project site.

### **B. Agency Comments**

1. **Canby Fire Department (M. English), dated July 9, 2020.** The Canby Fire Department Division Chief provided a list of requirements related to fire protection and provision of emergency services to land uses on the project site. These requirements are referenced below under Section V of this Staff Report. Canby Fire's comments also include a conceptual plan for fire hydrant locations.
2. **City Engineer (H. Ibrahim), dated July 16, 2020.** The City Engineer provided a memo outlining requirements for public improvements, including half-street improvements on SE 1<sup>st</sup> Avenue and S Walnut Street, and for utility improvements to serve the project site and adjacent parcels. These

requirements are listed below under Section V of this Staff Report as conditions of approval.

#### **IV. Conclusion**

Staff has reviewed the applicant's narrative and submitted application materials and finds that this Site and Design Review application conforms to the applicable review criteria and standards, subject to the conditions of approval noted in Section V of this report.

#### **V. Conditions of Approval**

##### **Street and Utility Improvements:**

1. Public improvements shall comply with all applicable City of Canby Public Works Design Standards. Identified street improvements and right-of-way dedications must be designed and constructed (or bonded) to the satisfaction of the City Engineer. (R. Potter)
2. The street classification of this roadway has been updated from a Local Street to an Industrial Collector Street; the existing right-of-way is 40 feet, or 20 feet on each side of the centerline. The applicant shall dedicate an additional 17 feet of right-of-way on SE 1<sup>st</sup> Avenue to accommodate buildout of a street section consistent with an Industrial Collector street classification. Half-street improvements shall be required along the entire site frontage of SE 1<sup>st</sup> Avenue where the curb line is placed at 25 feet from the right-of-way centerline. Improvements shall include 5-foot planter strips and 6-foot-wide concrete sidewalks, street lights, and street trees. The applicant shall identify a 12-foot-wide public utility easement (PUE) abutting the new right-of-way dedication on SE 1<sup>st</sup> Avenue. (H. Ibrahim)
3. The minimum centerline horizontal radius for collector streets shall be 270 feet. (H. Ibrahim).
4. The sanitary sewer in SE 1<sup>st</sup> Avenue shall be extended from Hazel Dell Way to the intersection with S Walnut Street. The location of the manhole shall not conflict with the turnabout configuration while the depth of the manhole at S Walnut Street needs to be a minimum of 14 feet to accommodate serving the properties on both sides of the future S Walnut Street extension to Highway 99E. (H. Ibrahim)
5. A public 8-inch sewer line shall be extended along the westerly property line of the project site and extended to the southerly property line, terminating with a minimum of an 8-foot deep manhole to serve the remaining undeveloped properties to the south. (H. Ibrahim)
6. Right-of-way dedication shall be required at the intersection of SE 1<sup>st</sup> Avenue and S Walnut Street to accommodate the future turnabout as part of a planned extension of S Walnut Street to Highway 99E. Prior to approval of construction documents for public improvements related to the proposed project, the project design shall be modified to reflect the design of the future turnabout as shown in construction drawings provided to the project applicant by the City Engineer. (H. Ibrahim)
7. Consistent with the City of Canby Industrial Area Master Plan prepared by OTAK Engineering, date October 1998, and the City Transportation System Plan (TSP), half-street improvements to S Walnut along the project site's eastern frontage shall be constructed to a local street standard as per the Public Works Design Standards. Half-street improvements shall be constructed along the entire site frontage from the south terminus half-street improvements to SE 1<sup>st</sup> Avenue to match the ultimate

existing paved street width of 32 feet to include a planter strip and 6-foot-wide concrete sidewalk. A 12-foot public utility easement (PUE) shall be provided. (H. Ibrahim)

8. Access driveways along Walnut Street shall be industrial type with large-radius curb returns to account for truck traffic. (H. Ibrahim)
  9. Driveways widths shall be a maximum of 40-feet wide as per City of Canby Municipal Code unless specifically allowed by the City Engineer. (H. Ibrahim)
  10. All driveways shall have an industrial driveway approach consisting of 8-inch minimum concrete thickness with reinforcements or mesh welded wire fabric. (H. Ibrahim)
  11. The curb return radii at intersections and driveways shall be large enough to allow for AASHTO WB-67 vehicle turning movements. The property line shall be concentric with this return. The applicant's engineer shall submit to the City truck turning movement templates demonstrating that the turning movement requirements are met. (H. Ibrahim)
  12. All private storm drainage shall be disposed onsite. The design methodology shall be in conformance with the City of Canby December 2019 Public Works Standards. (H. Ibrahim)
  13. The applicant shall demonstrate how the storm runoff generated from the new impervious surfaces will be disposed. If drywells (UIC) are used as a means to discharge storm runoff from private streets, they must meet the following criteria:
    - a. The UIC structures' location shall meet at least of the two conditions:
      - i. The vertical separation distance between the UIC and seasonal high groundwater is more than 2.5 feet, or
      - ii. The horizontal separation distance between the UIC and any water well is a minimum of 267 feet in accordance with the City of Canby Stormwater Master Plan, Appendix "C", *Groundwater Protectiveness Demonstration and Risk Prioritization for Underground Injection Control Devices*.
- The storm water drainage report shall be in conformance with the requirements as stated in Chapter 4 of the City of Canby Public Works Design Standards dated December 2019. (H. Ibrahim)
14. Any existing domestic or irrigation wells shall be abandoned in conformance with OAR 690-220-0030. A copy of an Oregon Water Rights Department (OWRD) abandonment certificate shall be submitted to the City. (H. Ibrahim)
  15. Any existing onsite sewage disposal system shall be abandoned in conformance with DEQ and Clackamas County Water Environmental Services (WES) regulations. A copy of the septic tank removal certificate shall be submitted to the City. (H. Ibrahim)
  16. Water services and fire protection shall be constructed in conformance with Canby Utility and Canby Fire Department requirements. (H. Ibrahim)
  17. The project applicant shall coordinate with CFD to identify appropriate locations for fire hydrants. Prior to site plan approval, the project applicant shall provide an updated site plan identifying hydrant locations to the satisfaction of CFD. (M. English/R. Potter)

**Site Access:**

18. Circulation of truck traffic to or from the project site via S Haines Road shall be generally limited to extraordinary or emergency use. The future property owners of the three proposed parcels shall distribute information to their tenants on a regular basis identifying a requirement that truck trips generated by the project site use SE 1<sup>st</sup> Avenue/SE Hazel Dell Way and S Walnut Street to access Sequoia Parkway until either: (1) the alternative industrial access road to Highway 99E from S Walnut Street is completed, or (2) S Haines Road has been brought up to a collector street standard up to Highway 99E. (R. Potter)

**Partition/Final Plat and Survey Accuracy:**

19. The partition plat shall reflect additional right-of-way dedication required to accommodate a future turnabout at the intersection of SE 1<sup>st</sup> Avenue and S Walnut Street. This right-of-way dedication shall be consistent with the construction drawings provided to the project applicant by the City Engineer. (H. Ibrahim/R. Potter)
20. All public improvements are typically installed prior to the recordation of the final plat. If the applicant wishes to forgo construction of any portion of the public improvements until after the recordation of the final plat, then the applicant shall provide the City with appropriate performance security (subdivision performance bond or cash escrow) in the amount of 110% of the cost of the remaining public improvements to be installed and enter into an agreement outlining the timing of the bonded improvements. (R. Potter)
21. The applicant shall apply for final plat approval at the City and pay any applicable City fees to gain approval of the final partition plat. Prior to the recordation of the final plat at Clackamas County, it must be approved by the City and all other applicable agencies. The City will distribute the final plat to applicable agencies for comment prior to signing off on the final plat if deemed necessary. (R. Potter)
22. All public improvements or submittal of necessary performance security assurance shall be made prior to the signing and release of the final plat for filing of record. (R. Potter)
23. The final plat shall conform to the necessary information requirements of CMC 16.68.030, 16.68.040(B), and 16.68.050. The City Engineer or County Surveyor shall verify that these standards are met prior to the recordation of the plat. (R. Potter)
24. The applicant shall work with Canby Utility and Canby Public Works Department in order to provide the appropriate connections to all required utilities as well as demonstrate final utility easement placement, prior to final map recordation. (R. Potter)
25. Clackamas County Surveying reviews pending partition plat documents for Oregon Statutes and County requirements. A final plat prepared in substantial conformance with the approved tentative plat must be submitted to the City for approval within one year of approval of the tentative plat or formally request an extension of up to 6-months with a finding of good cause. (R. Potter)
26. The project applicant shall record the final plat at Clackamas County within 6 months of the date of the signature of the Planning Director. (R. Potter)



27. The applicant shall assure that the City is provided with a copy of the final plat in a timely manner after it is recorded at Clackamas County, including any CC&Rs, if applicable, recorded in conjunction with the final plat. (R. Potter)
28. The placement of utility easements, including 12-foot-wide public utility easements along SE 1<sup>st</sup> Avenue and S Walnut Street, shall be noted on the final plat. Utility easements may be combined with other easements and shall be measured from the property boundary. (R. Potter)
29. The County Surveyor shall verify that the survey accuracy and monumentation requirements set forth in Oregon Revised Statutes and CMC 16.64.070(M) are met prior to the recordation of the final plat. Installation of the front lot monumentation (along and within street rights-of-way) and the replacement of any existing monuments destroyed during improvement installation shall be confirmed by the City Engineer or County Surveyor prior to the recordation of the final partition plat. (R. Potter)
30. Monuments shall be reestablished and protected in monument boxes at every street intersection and all points of curvature and points of tangency of street centerlines as required by Oregon Revised Statutes Chapter 92. The City Engineer or County Surveyor shall verify compliance with this condition prior to the recordation of the final plat. (R. Potter)

**Project Design/Site Plan Approval:**

31. Consistent with Subsection 16.10.100, *Bicycle Parking*, of the Municipal Code, the proposed project shall be modified to provide bicycle parking within 50 feet of the main entrance of each building. Prior to site plan approval, the project applicant shall submit a final site plan demonstrating that the location and design of proposed bicycle parking conforms to the aforementioned code section. (R. Potter)
32. Consistent with Subsection 16.49.120, *Parking Lot Landscaping Standards*, the proposed surface parking shall be redesigned to “break up the parking area into rows of not more than 8 contiguous spaces.” Prior to site plan approval, the applicant shall submit to the City a revised site plan demonstrating compliance with this condition, along with revised landscaping calculations reflecting the change in site design/lot coverage. (R. Potter)
33. Prior to site plan approval, a lighting plan shall be submitted to the City consistent with Chapter 16.43, *Outdoor Lighting Standards*, of the Municipal Code. This shall include an exhibit(s) demonstrating that the proposed light fixtures would be shielded and that light generated would not exceed the maximum lumens identified in Table 16.43.070 of the Canby Municipal Code. (R. Potter)
34. Prior to site plan approval, the project applicant shall provide Canby Public Works with construction drawings compliant with the Canby Municipal Code and Canby Public Works Standards, to the satisfaction of the City Engineer. (R. Potter)

**Building Permits:**

35. Prior to the pre-construction meeting and issuance of grading permits, the applicant shall comply with all applicable Canby Fire District (CFD) requirements as identified in the memo received from CFD and attached to this Staff Report. Please contact the CFD Division Chief at 503-266-5851 for further information. (M. English)
36. The project applicant shall secure a Street Opening and/or Driveway Construction permit for all paved driveway or utility installations associated with the proposed

development or offsite improvements. Said permits shall comply with the City's Public Works Design Standards. (R. Potter)

37. The design engineer shall submit to the City of Canby for review and approval at the time of final construction plan approval a storm drainage analysis and report applicable to the defined development area detailing how storm water disposal from both the building and the parking areas is being handled. Any drainage plan shall conform to an acceptable methodology for meeting adopted storm drainage design standards as indicated in the Public Works design standards. (R. Potter)
38. Construction plans shall be designed and stamped by a Professional Engineer registered in the State of Oregon. (R. Potter)
39. Prior to occupancy, sight distance at all access points will need to be verified, documented, and stamped by a registered professional Civil or Traffic Engineer licensed in the State of Oregon. (R. Potter)
40. The project applicant shall apply for a City of Canby Site Plan Permit, Clackamas County Building permits, and a City of Canby Erosion Control Permit from the Canby Public Works Department. (R. Potter)
41. Clackamas County Building Codes Division will provide structural, electrical, plumbing, and mechanical plan review and inspection services for construction of the project. (R. Potter)
42. The applicant shall file a sign permit for any future signs that shall be limited to the size and height standards applicable to the I-O (Canby Industrial Area Overlay Zone) as indicated in Section 16.42.050, Table 7, of the sign ordinance. Proposed signs, after been found to conform to the sign ordinance, must secure a building permit from Clackamas County Building Inspection prior to their installation. (R. Potter)

**During Construction:**

43. If a gravesite is discovered during earthmoving or construction activities, the applicant or contractor shall notify the City and Zoar Lutheran Church prior to further disturbance of the discovery. The applicant and contractors shall comply with all applicable state and federal regulations pertaining to discovery and treatment (e.g., removal or preservation-in-place) of human remains. (R. Potter)

**Prior to Occupancy:**

44. Prior to occupancy of the facility, all landscaping plant material indicated on the submitted landscape plan shall either be installed and irrigated as proposed, or sufficient security (bonding, escrow, etc.) shall be provided pursuant to the provisions of CMC 16.49.100 (B). The applicant should be aware that the City street tree fee is now \$250 per tree if planted by the City, and the City recommends submittal of a separate Street Tree Plan to assist in the location, species, and total tree count. (R. Potter)



City of Canby  
 Planning Department  
 222 NE 2<sup>nd</sup> Avenue  
 P.O. Box 930  
 Canby, OR 97013  
 Ph: 503-266-7001  
 Fax: 503-266-1574

# LAND USE APPLICATION

## MINOR PARTITION Process Type III MAJOR PARTITION Process Type III

**APPLICANT INFORMATION:** (Check ONE box below for designated contact person regarding this application)

Applicant Name: VLMK Engineering + Design-Jennifer Kimura Phone: 503.222.4453  
 Address: 3933 SW Kelly Avenue Email: jenniferk@vlmk.com  
 City/State: Portland, Oregon Zip: 97239

Representative Name: \_\_\_\_\_ Phone: \_\_\_\_\_  
 Address: \_\_\_\_\_ Email: \_\_\_\_\_  
 City/State: \_\_\_\_\_ Zip: \_\_\_\_\_

Property Owner Name: TC/EIL Baker, LLC Phone: 503.946.4980  
a Delaware limited liability company  
 Signature: Steven J Wells Digitally signed by Steven J Wells  
Date: 2020.04.27 15:59:39 -07'00'  
 Address: 1300 SW 5TH Suite 3350 Email: SSieber@trammellcrow.com  
 City/State: Portland, OR Zip: 97201

Property Owner Name: \_\_\_\_\_ Phone: \_\_\_\_\_  
 Signature: \_\_\_\_\_  
 Address: \_\_\_\_\_ Email: \_\_\_\_\_  
 City/State: \_\_\_\_\_ Zip: \_\_\_\_\_

NOTE: Property owners or contract purchasers are required to authorize the filing of this application and must sign above

- ① All property owners represent they have full legal capacity to and hereby do authorize the filing of this application and certify that the information and exhibits herewith submitted are true and correct.
- ② All property owners understand that they must meet all applicable Canby Municipal Code (CMC) regulations, including but not limited to CMC Chapter 16.49 Site and Design Review standards.
- ③ All property owners hereby grant consent to the City of Canby and its officers, agents, employees, and/or independent contractors to enter the property identified herein to conduct any and all inspections that are considered appropriate by the City to process this application.

**PROPERTY & PROJECT INFORMATION:**

<u>Southeast 1st Avenue between S. Hazel Dell Way and S. Walnut Street</u>	<u>20.21 acres</u>	<u>31E34 00300</u>
Street Address or Location of Subject Property	Total Size of Property	Assessor Tax Lot Numbers
<u>N/A</u>	<u>M1-IO</u>	
Existing Use, Structures, Other Improvements on Site	Zoning	Comp Plan Designation

Proposed construction of (3) new spec buildings, associated site work and partition that will include 3 separate parcels  
 Describe the Proposed Development or Use of Subject Property

STAFF USE ONLY				
FILE #	DATE RECEIVED	RECEIVED BY	RECEIPT #	DATE APP COMPLETE





City of Canby  
 Planning Department  
 222 NE 2<sup>nd</sup> Avenue  
 PO Box 930  
 Canby, OR 97013  
 (503) 266-7001

# LAND USE APPLICATION

---

## SITE AND DESIGN REVIEW

### General Type III

---

**APPLICANT INFORMATION:** (Check ONE box below for designated contact person regarding this application)

Applicant Name: VLMK Engineering + Design-Jennifer Kimura Phone: 503.222.4453  
 Address: 3933 SW Kelly Avenue Email: jenniferk@vlmk.com  
 City/State: Portland, Oregon Zip: 97239

Representative Name: \_\_\_\_\_ Phone: \_\_\_\_\_  
 Address: \_\_\_\_\_ Email: \_\_\_\_\_  
 City/State: \_\_\_\_\_ Zip: \_\_\_\_\_

Property Owner Name: TC/EIL Baker, LLC Phone: 503.946.4980  
a Delaware limited liability company  
 Signature: Steven J Wells Digitally signed by Steven J Wells  
Date: 2020.04.27 15:57:31 -07'00'  
 Address: 1300 SW 5TH Suite 3350 Email: \_\_\_\_\_  
 City/State: Portland, OR Zip: 97201

Property Owner Name: \_\_\_\_\_ Phone: \_\_\_\_\_  
 Signature: \_\_\_\_\_  
 Address: \_\_\_\_\_ Email: \_\_\_\_\_  
 City/State: \_\_\_\_\_ Zip: \_\_\_\_\_

NOTE: Property owners or contract purchasers are required to authorize the filing of this application and must sign above

- All property owners represent they have full legal capacity to and hereby do authorize the filing of this application and certify that the information and exhibits herewith submitted are true and correct.
- All property owners understand that they must meet all applicable Canby Municipal Code (CMC) regulations, including but not limited to CMC Chapter 16.49 Site and Design Review standards.
- All property owners hereby grant consent to the City of Canby and its officers, agents, employees, and/or independent contractors to enter the property identified herein to conduct any and all inspections that are considered appropriate by the City to process this application.

**PROPERTY & PROJECT INFORMATION:**

<u>Southeast 1st Avenue between S. Hazel Dell Way and S. Walnut Street</u>	<u>20.21 acres</u>	<u>31E34 00300</u>
Street Address or Location of Subject Property	Total Size of Property	Assessor Tax Lot Numbers
<u>N/A</u>	<u>M1-IO</u>	
Existing Use, Structures, Other Improvements on Site	Zoning	Comp Plan Designation

Proposed construction of (3) new spec buildings, associated site work and partition that will include 3 separate parcels  
 Describe the Proposed Development or Use of Subject Property

STAFF USE ONLY				
FILE #	DATE RECEIVED	RECEIVED BY	RECEIPT #	DATE APP COMPLETE



## PROJECT NARRATIVE

---

<i>Project Name:</i>	Baker Center	<i>Applicant:</i>	VLMK Engineering + Design
<i>Project Address:</i>	SE 1 <sup>st</sup> Ave and S Walnut Canby, OR 97013	<i>Contact:</i>	503.222.4453 Greg Blefgen, VLMK
		<i>Developer:</i>	Steve Sieber, Trammell Crow Company

---

The Baker Center Industrial Project encompasses Tax Lot #31E34 00300 which is located at Southeast 1st Avenue between S. Hazel Dell Way and S. Walnut Street. The development will include a partition of the 20.21 acre parcel that will create 3 separate parcels and the phased construction of three new speculative buildings that will be designed to accommodate a combination of warehouse and light manufacturing tenants. The phasing of the development will be initiated with the frontage and infrastructure improvements followed by the development of 1 or more of the buildings with anticipated completion to occur within a 5 year development period.



**DESIGN CRITERIA RESPONSE**

*Project Name:* Baker Center  
*Project Address:* SE 1<sup>st</sup> Ave and S Walnut  
Canby, OR 97013

*Applicant:* VLMK Engineering + Design  
503.222.4453  
*Contact:* Greg Blefgen, VLMK  
*Developer:* Steve Sieber, Trammell Crow  
Company

**TABLE OF CONTENTS**

Chapter 16.08 General Provisions ..... 4  
    16.08.010 Compliance with title. .... 4  
    16.08.20 Zoning map. .... 4  
    16.08.040 Zoning of annexed areas. .... 4  
    16.08.050 Prohibited parking. .... 4  
    16.08.070 Illegally created lots. .... 5  
    16.08.80 Area and yard reductions. .... 5  
    16.08.90 Sidewalks required..... 6  
    16.08.100 Height allowances. .... 6  
    16.08.110 Fences. .... 6  
    16.08.115 Arbors ..... 8  
    16.08.120 Siting and review process for Wireless Telecommunications Systems Facilities. .... 9  
    16.08.130 Standard transportation improvements..... 14  
    16.08.140 Temporary vendor..... 16  
    16.08.150 Traffic Impact Study (TIS)..... 18  
    16.08.160 Safety and Functionality Standards..... 22  
Chapter 16.10 Off-Street Parking and Loading ..... 24  
    16.10.10 Off-street parking required – exceptions..... 24  
    16.10.20 Definitions. .... 25  
    16.10.30 General requirements. .... 25  
    16.10.040 Prohibited near intersections..... 27  
    16.10.050 Parking standards designated..... 27  
TABLE 16.10.050 ..... 27  
    16.10.60 Off-street loading facilities..... 29

16.10.70 Parking lots and access..... 31

16.10.080 Street tree plan. .... 41

16.10.90 Drive-up uses. .... 41

16.10.100 Bicycle Parking. .... 42

Chapter 16.32 M-1 Light Industrial Zone ..... 43

    16.32.10 Uses permitted outright. .... 43

    16.32.20 Conditional uses. .... 46

    16.32.30 Development standards..... 46

Chapter 16.35 Canby Industrial Overlay (I-O) Zone..... 48

    16.35.010 Purpose. .... 48

    16.35.20 Applicability..... 48

    16.35.25 Pre-application review and conditions of approval..... 49

    16.35.030 Uses permitted outright. .... 50

    16.35.40 Conditional uses. .... 50

    16.35.45 Prohibited uses. .... 52

    16.35.50 Development standards..... 53

    16.35.60 Design guidelines..... 56

    16.35.70 I-O Design review matrix. .... 57

Chapter 16.42 SIGNS..... 58

Chapter 16.43 Outdoor Lighting Standards ..... 58

    16.43.40 Lighting Zones. .... 58

    Table 16.43.040 Lighting Zone Descriptions..... 59

    16.43.60 Prohibited Light and Lighting. .... 59

    16.43.70 Luminaire Lamp Lumens, Shielding, and Installation Requirements..... 60

    Table 16.43.070 – Luminaire Maximum Lumens and Required Shielding ..... 61

    16.43.80 Height Limits..... 61

    Table 16.43.080 – Maximum Lighting Mounting Height ..... 62

    Figure 16.43.2: Mounting Height ..... 63

    16.43.090 Lighting Controls..... 63

    16.43.100 Exceptions to Standards..... 63

    16.43.110 Lighting Plan Required ..... 64

Chapter 16.46 Access Limitations ..... 64

    16.46.10 Number of units in residential development..... 64

16.46.20 Ingress and egress. .... 66

16.46.30 Access connection..... 67

TABLE 16.46.30 Access Management Guidelines for City Streets\* ..... 67

16.46.035 Restricted access. .... 67

16.46.40 Joint and cross access. .... 68

16.46.50 Nonconforming access features..... 69

16.46.060 Amount of access points. .... 69

16.46.70 Exception standards. .... 69

16.46.80 State highway standards..... 71

16.46.90 Shared access onto state highway. .... 71

Chapter 16.49 Site and Design Review ..... 71

Chapter 16.50 Conditional Uses..... 71

Chapter 16.60 Partitions ..... 72

    16.60.030 Partitions ..... 72

Chapter 16.89 Application and Review Procedures ..... 72

Chapter 16.120 Parks, Open Space, and Recreational Land ..... 72

    16.120.010 Purpose ..... 72

    16.120.20 Minimum standard for park, open space and recreation land ..... 73

    16.120.30 Dedication procedures..... 75

    16.120.40 Cash in lieu of dedication of land ..... 76

    16.120.050 Review procedure ..... 78

    16.120.60 Partial credit for private park, open space and recreational facilities/areas:..... 78

## DESIGN CRITERIA RESPONSE

### CHAPTER 16.08 GENERAL PROVISIONS

#### 16.08.010 COMPLIANCE WITH TITLE.

No building, structure, or land shall hereafter be used or occupied, and no building, structure or part thereof shall hereafter be erected, constructed, reconstructed, moved or structurally altered contrary to the provisions of this title. No lot area, yard, or required off-street parking or loading area existing on or after the effective date of the ordinance codified in this title shall be reduced in area, dimension, or size below the minimums required by this title, nor shall any lot area, yard, or required off-street parking or loading area that is required by this title for one use be used to satisfy the lot area, yard, off-street parking or loading area requirement for any other use, except as may be provided in this title. (Ord. 740 section 10.3.05(A), 1984)

#### 16.08.20 ZONING MAP.

- A. The location and boundaries of the zones designated in this division are established as shown on the map entitled "Zoning Map of the City of Canby" dated with the effective date of the ordinance codified in this title and signed by the Mayor and the city recorder and hereafter referred to as the zoning map.

***Findings:** The property is situated in the I-O Canby Industrial Area Overlay zone (Pioneer Industrial Park) which permits uses in the underlying M-1 zone. The M-1 Zone states in 16.32.010 that uses permitted outright in the M-1 Zone includes (A) "Manufacturing," (T) "Warehouse," and (X) "Business or Professional Office, When Related and Incidental to the Primary Industrial Uses of the Area."*

- B. The signed copy of the zoning map shall be maintained on file in the office of the city recorder and is made a part of this title. (Ord. 740 section 10.3.05(B), 1984)

#### 16.08.040 ZONING OF ANNEXED AREAS.

Zoning of newly annexed areas shall be considered by the Planning Commission in its review and by the Council in conducting its public hearing for the annexation. (Ord. 740 section 10.3.05(D), 1984) (Ord. 1294, 2008)

***Findings:** This criterion does not apply to this project. The proposed development has previously been annexed.*

#### 16.08.050 PROHIBITED PARKING.

In addition to the provisions of the motor vehicle laws of Oregon regulating parking, no person shall park any vehicle, except an automobile, motorcycle, van or pickup truck rated no larger than one ton, on any public street or alley within any residential zone, except for an emergency or for the purpose of loading or unloading. (Ord. 740 section 10.3.05(E), 1984)

***Findings:*** *This criterion does not apply to this project. The proposed development is not located within a residential zone.*

**16.08.070 ILLEGALLY CREATED LOTS.**

In no case shall a lot which has been created in violation of state statute or city ordinance be considered as a lot of record for development purposes, until such violation has been legally remedied. (Ord. 740 section 10.3.05(G), 1984)

***Findings:*** *The proposed development meets or exceeds these Required Conditions. The proposed development will occur on a lot that has been properly recorded in accordance with the statutes of governing jurisdictions. All proposed lots to be created by the development will be established in accordance with jurisdictional requirements.*

**16.08.80 AREA AND YARD REDUCTIONS.**

- A. When there are existing dwellings on the lots situated immediately to each side of a given lot and each of those neighboring lots has less than the required street yard depth, the street yard of the subject property may be reduced to the average street yard of those two abutting lots.

***Findings:*** *This criterion does not apply to this project. The proposed development does not propose to reduce the required yard depth with all proposed parcels meeting this requirement.*

- B. When there is an existing dwelling situated on a lot immediately to either side of a given lot which fronts on the same street, and such existing dwelling has a street yard which is less than half of that required in the zone, the street yard of the subject property may be reduced to a depth which is halfway between that normally required in the zone and that of the existing dwelling on the neighboring lot.

***Findings:*** *This criterion does not apply to this project. The proposed development does not propose to reduce the required yard depth with all proposed parcels meeting this requirement.*

- C. If, on the effective date of the ordinance codified in this title, a lot or the aggregate of contiguous lots held in a single ownership has less than the required area or width, the lot or lots may be occupied by a permitted use subject to the other requirements of the zone; provided that if the deficiency is one of area, residential uses shall be limited to single-family dwellings; and further provided that if the deficiency is one of width, each required interior yard may be reduced by one foot for each four feet of deficient width. In no case, however, shall such reduction result in an interior yard of less than five feet.

***Findings:*** *This criterion does not apply to this project. The proposed development does not propose to reduce the required yard area with all proposed parcels meeting this requirement.*

- D. Where two or more contiguous substandard recorded lots are in common ownership and are of such size to constitute at least one conforming zoning lot, such lots or portions thereof shall

be so joined, developed, and used for the purpose of forming an effective and conforming lot or lots. Such contiguous substandard lots in common ownership shall be considered as being maintained in common ownership after the effective date of the ordinance codified in this title for zoning purposes. (Ord. 740 section 10.3.05(H), 1984; Ord. 1237, 2007)

***Findings:*** *This criterion does not apply to this project. The existing and proposed lots are not substandard and are conforming zoned lots.*

#### **16.08.90 SIDEWALKS REQUIRED.**

- A. In all commercially zoned areas, the construction of sidewalks and curbs (with appropriate ramps for the handicapped on each corner lot) shall be required as a condition of the issuance of a building permit for new construction or substantial remodeling, where such work is estimated to exceed a valuation of twenty thousand dollars, as determined by the building code. Where multiple permits are issued for construction on the same site, this requirement shall be imposed when the total valuation exceeds twenty thousand dollars in any calendar year.

***Findings:*** *The proposed development meets or exceeds these Required Conditions. The proposed development includes City standard sidewalks, curbs and ramps.*

- B. The Planning Commission may impose appropriate sidewalk and curbing requirements as a condition of approving any discretionary application it reviews. (Ord. 740 section 10.3.05(I), 1984)

***Findings:*** *The proposed development meets or exceeds these Required Conditions. The proposed development includes City standard sidewalks, curbs and ramps.*

#### **16.08.100 HEIGHT ALLOWANCES.**

The following types of structures or structural posts are not subject to the building height limitations: chimneys, cupolas, tanks, church spires, belfries, derricks, fire and hose towers, flagpoles, water tanks, elevators, windmills, utility poles and other similar projections. The height of wireless telecommunications systems facilities shall be in accordance with section 16.08.120. (Ord. 740 section 10.3.05(J), 1984; Ord. 981 section 18, 1997)

***Findings:*** *This criterion does not apply to this project. The proposed development does not include any of the above listed exceptions to the height limitations. If such an item is desired by the owner, it is understood that as part of this section it will be allowed.*

#### **16.08.110 FENCES.**

- A. Fences not more than three and one-half feet in height may be constructed within the street setbacks of any R-1, R-1.5, R-2 or C-1 zone. Fences not more than six feet in height may be constructed in any interior yard, rear yard, or street yard along an alley; provided, however, that in no case shall a fence be constructed in violation of the requirements of a vision clearance area.



**Findings:** *This criterion does not apply to this project. The proposed development does not lie within the above listed zones and fences are not proposed within the street setback.*

- B. On corner lots, the 3.5-foot height limit will apply within the required setback along both street-facing yards.

**Findings:** *This criterion does not apply to this project. The proposed development does not lie on a corner lot and fences are not proposed within the street setback.*

- C. No more than one row of fencing is allowed within a required street yard setback.

**Findings:** *The proposed development is not proposing to have a fence installed within the required street yard setback.*

- D. The Planning Commission may require sight-blocking or noise mitigating fences for any development it reviews.

**Findings:** *The proposed development meets or exceeds these Required Conditions. Screening of parking and loading areas shall be achieved with landscape buffers. The truck courts are being screened with dense evergreen plantings within a supplemental landscape strip at the entrance into the truck court.*

- E. Fences of up to eight feet in height are permitted for any development in C-2, C-M, M-1 or M-2, or Planned Unit Development zones.

**Findings:** *Fencing meeting the requirements of the development code will be provided along the south and west property lines with safety fencing provided as appropriate at the retaining walls.*

- F. No fence/wall shall be constructed throughout a subdivision, planned unit development or be part of a project that is/was subject to site and design review approval where the effect or purpose is to wall said project off from the rest of the community unless reviewed and approved by the Planning Commission. (Ord. 890 section 8, 1993; Ord. 740 section 10.3.05(K), 1984; Ord. 955 section 2, 1996; Ord. 981 section 43, 1997)

**Findings:** *This criterion does not apply to this project. The proposed development does not propose to construct any wall or fence for the purpose of 'walling' off the development from the rest of the City.*

- G. In all zones, private fences along a public pedestrian/bicycle pathway shall comply with the following in order to provide security and visibility for pathway users while maintaining privacy for the residence.

1. Fencing installed as part of a new subdivision shall comply with either (a) or (b) below.

2. Fencing installed by a property owner on an individual lot shall comply with either (a), (b), or (c) below.
  - a. Solid fencing shall be no greater than four (4) feet in height; or
  - b. Fencing shall be constructed with black open wire material, wooden slats, or some other material that allows visual access between the pathway and adjacent uses; or
  - c. Solid fencing shall be set back at least three (3) feet from the property line that abuts the pathway.

**Findings:** *This criterion does not apply to this project. The proposed development does not include any fencing along the public pedestrian/bicycle pathway.*

#### **H. Use of hazardous materials.**

Fences and walls shall not be constructed of or contain any material which will do bodily harm, such as electric or barbed wire, razor wire, broken glass, spikes, or any other hazardous or dangerous material, except as follows:

- a. Barbed wire or electrified fences enclosing livestock are permitted in any zone permitting farm use. Electrified fences shall be posted or flagged at not less than 25-foot intervals with clearly visible warnings of the hazard when adjacent to developed areas.
- b. In commercial and industrial zones barbed wire is permitted attached to the top of a fence that is at least six foot in height above grade; provided, that barbed wire shall not extend over a street, sidewalk, alley or roadway. The attached barbed wire shall be placed at least six inches above the top of the fence. (Ord. 890 section 8, 1993; Ord. 740 section 10.3.05(K), 1984; Ord. 955 section 2, 1996; Ord. 981 section 43, 1997; Ord. 1338, 2010; Ord. 1514, 2019)

**Findings:** *The proposed development meets or exceeds these Required Conditions. Proposed fencing will be a chain link type with the possibility of barbed wire at the top as permitted in this section.*

#### **16.08.115 ARBORS**

- A. Arbors that are constructed of proper design (height and setbacks) and in accordance with, the design standards of the particular zone where it is located are allowed with the following limitations:
  1. Arbors shall be stand-alone structures and shall not be attached to a fence.
  2. The arbor shall not exceed eight feet in height and shall maintain a five foot setback from the property line.

3. If the vegetation becomes too full or too high, the owner is financially responsible to rectify the situation, and to maintain the vegetation, and arbor;
4. The primary purpose of the arbor is to support and sustain foliage/vegetation, provide shade, recreational space, and ascetic amenity. (Ord. 1514, 2019)

**Findings:** *This criterion does not apply to this project. The proposed development does not include any proposed Arbors.*

### **16.08.120 SITING AND REVIEW PROCESS FOR WIRELESS TELECOMMUNICATIONS SYSTEMS FACILITIES.**

- A. The purpose of this section is to provide standards and review process for wireless telecommunications systems facilities locating within the City of Canby. This purpose shall be realized by implementing new provisions of the Canby Land Development and Planning Ordinance that will:
  1. Regulate the placement, appearance and number of wireless telecommunications systems facilities;
  2. Ensure that the citizens of Canby will have access to a variety of wireless telecommunications systems and providers;
  3. Reduce the visual impact of certain wireless telecommunications systems facilities by encouraging collocation;
  4. Establish a graduated system of review that will expedite facilities placement in preferred locations; and
  5. Implement the applicable provision of the Federal Telecommunications Act of 1996.
- B. The siting and review process for WTS facilities is based on the type of facility (lattice, monopole, attached, stealth design or collocation) and its proposed location in a Preferred Site (M-1 or M-2 zoning districts), Acceptable Site (C-2 or C- M zoning districts), or Conditionally Suitable Site (C-R, C-C or C-1 zoning districts).
- C. The development review process for wireless telecommunications systems (WTS) facilities shall be as follows:
  1. Building and Electrical Permits only:
    - a. An attached WTS facility (existing structure, including collocation on cell tower), including equipment shelters, buildings and cabinets housing WTS land line switching/connection equipment, on a Preferred Site or Acceptable Site, where

the height of the attached WTS facility is no more than 10 feet higher than the existing structure.

- b. A detached WTS facility (monopole), including equipment shelters, buildings and cabinets housing WTS land line switching/connection equipment, on a Preferred Site, set back at least 660 feet from Highway 99E or land either planned or zoned for residential use, and less than 150 feet in height, including antennas.
  - c. A detached, stealth design WTS facility (monopole), including equipment shelters, buildings and cabinets housing WTS land line switching/connection equipment, on an Acceptable Site, set back from all property lines a distance equal to or greater than the height of the tower, and less than 60 feet high.
2. Building and Electrical Permits, and Site and Design Review (16.49):
- a. An attached WTS facility (existing structure, including collocation on cell tower), including equipment shelters, buildings and cabinets housing WTS land line switching/connection equipment, on a Preferred Site or Acceptable Site, where the height of the attached WTS facility is more than 10 feet higher than the existing structure.
  - b. A detached WTS facility (monopole), including equipment shelters, buildings and cabinets housing WTS land line switching/connection equipment, on a Preferred Site, set back at least 660 feet from Highway 99E or land either planned or zoned for residential use, and equal to or over 150 feet in height, including antennas.
  - c. A detached WTS facility (monopole), including equipment shelters, buildings and cabinets housing WTS land line switching/connection equipment, on a Preferred Site, within 660 feet from Highway 99E or land either planned or zoned for residential use, and under 100 feet in height, including antennas.
  - d. A detached WTS facility (lattice tower), including equipment shelters, buildings and cabinets housing WTS land line switching/connection equipment, on a Preferred Site, set back at least 660 feet from Highway 99E or land either planned or zoned for residential use, and under 150 feet in height, including antennas.
  - e. A detached, stealth design WTS facility (monopole), including equipment shelters, buildings and cabinets housing WTS land line switching/connection equipment, on an Acceptable Site, set back from all property lines a distance equal to or greater than the height of the tower, and less than 100 feet high, including antennas.
3. Building and Electrical Permits, Site and Design Review (16.49), and Conditional Use Permit (16.50):

- a. A detached WTS facility (monopole), including equipment shelters, buildings and cabinets housing WTS land line switching/connection equipment, on a Preferred Site, within 660 feet from Highway 99E or land either planned or zoned for residential use, and equal to or over 100 feet in height, including antennas.
- b. A detached WTS facility (lattice tower), including equipment shelters, buildings and cabinets housing WTS land line switching/connection equipment, on a Preferred Site, set back at least 660 feet from Highway 99E or land either planned or zoned for residential use, and equal to or over 150 feet in height, including antennas.
- c. A detached, stealth design WTS facility (monopole), including equipment shelters, buildings and cabinets housing WTS land line switching/connection equipment, on an Acceptable Site, set back from all property lines a distance equal to or greater than the height of the tower, including, unless it is demonstrated that locating the proposed facility within the required setback area will take advantage of an existing natural or artificial feature to conceal the facility or minimize its visual impacts, and equal to or over 100 feet high, with a maximum height of 130 feet.
- d. An attached WTS facility (existing structure, including collocation on cell tower) on a Conditionally Suitable Site, including equipment shelters, buildings and cabinets housing WTS land line switching/connection equipment, where the height of the attached WTS facility is no more than 10 feet higher than the existing structure.

D. Standards for siting WTS facilities shall be as follows:

1. Site and Design Review standards and criteria (section 16.49.040) shall apply to all WTS facilities requiring Site and Design approval.
2. Conditional Use Permit standards and criteria (section 16.50.010) shall apply to all WTS facilities requiring Conditional Use Permit approval.
3. All WTS facilities shall observe minimum lot size, lot coverage, building height and building setback requirements of the underlying zoning district unless specifically exempted or otherwise regulated by this section. Underground facilities may encroach upon required yards or may be placed in appropriate easements.
4. All detached WTS facilities shall be landscaped at the base of the towers/poles, and completely around the equipment shelters. The landscaping shall conform to the ODOT standards for plant size and spacing.

5. Lighting for all WTS facilities shall be as required by the FAA or recommended by ODOT Aeronautics Division. All other lighting must be deflected away from adjoining property.
6. All detached WTS facilities shall be screened from the public right-of-way and abutting property by a security fence or wall at least 6 feet in height consisting of chain link fencing with vinyl slats, solid wood fencing, concrete masonry unit block, or brick.
7. Attached WTS facilities shall be painted to match the color of the mechanical screen wall or building to which it is attached.
8. Equipment shelters, buildings and cabinets housing radio electronics equipment shall be concealed, camouflaged or placed underground.
9. Any WTS facility sited on or designed with any of the following attributes shall first receive FCC approval, as specified in FCC Rules 1.1301 - 1.1319, as a condition of city approval prior to construction; Wilderness Area; Wildlife Preserve; Endangered Species; Historical Site; Indian Religious Site; Flood Plain; Wetlands; High Intensity White lights in residential neighborhoods; Excessive radio frequency radiation exposure.

E. Application requirements for WTS facilities shall be as follows:

1. WTS providers whose proposals conforms with the provisions of subsection (C)(1) of this section (16.08.120) shall submit the following information with the application for permits:
  - a. A copy of that portion of the lease agreement (or lease memo) with the property owner, facility removal within 90 days of the abandonment and a bond to guarantee removal shall be submitted for review prior to development permit approval.
  - b. A map of the city showing the approximate geographic limits of the cell to be created by the facility. This map shall include the same information for all other facilities owned or operated by the applicant within the city, or extending within the city from a distant location, and any existing detached WTS facilities of another provider within 1,000 feet of the proposed site.
  - c. A plot plan showing:
    - i. The lease area;
    - ii. Antenna structure;
    - iii. Height above grade and setback from property lines;

- iv. Equipment shelters and setback from property lines;
  - v. Access;
  - vi. Connection point with land line system; and
  - vii. All landscape areas associated with the WTS facility.
- d. Anticipated capacity of the WTS facility (including number and types of antennas which can be accommodated).
  - e. The method(s) of stealth design (where applicable).
  - f. An engineer's statement that the radio frequency emissions at grade, or at the nearest habitable space when attached to an existing structure comply with FCC rules for such emissions; the cumulative radio frequency emissions if collocated.
  - g. The radio frequency range in megahertz and the wattage output of the equipment.
  - h. A description of the type of service offered (voice, data, video, etc.) and the consumer receiving equipment.
  - i. Identification of the provider and backhaul provider, if different.
  - j. A facilities maintenance regimen.
  - k. The zoning and comprehensive plan designation of the proposed site.
  - l. The FAA determination.
  - m. The distance from the nearest WTS facility.
2. WTS providers whose proposals conforms with the provisions of subsection (C)(2) and (C)(3) of this section (16.08.120) shall submit, in addition to the requirements of 16.49.035 and/or 16.50.020 of the Land Development and Planning Ordinance, the following additional information:
- n. Items in section (E) above.
  - o. Alternatives for locating/relocating support structures within 250 feet of the proposed site.

- p. Photo simulations of the proposed WTS facility from the four cardinal compass points and/or abutting right-of-way, whichever provides the most accurate representation of the proposed facility from a variety of vantage points.
  - q. An engineer's statement demonstrating the reasons why the WTS facility must be located at the proposed site (service demands, topography, dropped coverage, etc.).
  - a. An engineer's statement demonstrating the reasons why the WTS facility must be constructed at the proposed height.
  - b. Verification of good faith efforts made to locate or design the proposed WTS facility to qualify for a less rigorous approval process (building permit and/or building permit and site and design review approval).
- F. Private amateur radio (HAM) antennas, their support structures, and direct to home satellite receiving antennas are exempt from this section (16.08.120), but shall otherwise comply with the applicable provisions of the underlying zoning district in which they are located to the extent that such provisions comply with Federal Communications Commission policy. (Ord. 981 section 19, 1997)

***Findings:*** *This criterion does not apply to this project. The proposed development does not include any proposed wireless telecommunications facilities.*

### **16.08.130 STANDARD TRANSPORTATION IMPROVEMENTS.**

- A. Pursuant to the Transportation Planning Rule, projects that are specifically identified in the Canby Transportation System Plan, for which the City has made all the required land use and goal compliance findings, are permitted outright and subject only to the standards established by the Transportation System Plan. This section pertains to additional transportation projects that may not be identified in the Canby Transportation System Plan, and whether the use is permitted outright or permitted subject to the issuance of a conditional use permit.
- 1. Except where otherwise specifically regulated by this ordinance, the following improvements are permitted outright:
    - a. Normal operation, maintenance, repair, and preservation of existing transportation facilities.
    - b. Installation of culverts, pathways, medians, fencing, guardrails, lighting, and similar types of improvements within the existing right-of-way.
    - c. Projects specifically identified in the Transportation System Plan as not requiring further land use regulation.
    - d. Landscaping as part of a transportation facility.



- e. Emergency measures necessary for safety and the protection of property.
  - f. Acquisition of right-of-way for public roads, highways, and other transportation improvements designated in the Transportation System Plan, except for those that are located in exclusive farm use or forest zones.
  - g. Construction of a local street or road as part of subdivision or land partition approved consistent with this Ordinance.
2. Except where otherwise specifically regulated by this ordinance, the following improvements are permitted as a conditional use:
- a. Construction, reconstruction, or widening, and other projects authorized by the Transportation System Plan but not included in the list of projects in the Transportation System Plan. These projects shall comply with the Transportation System Plan and applicable standards, and shall address the following criteria. For State projects that require an Environmental Impact Statement (EIS) or Environmental Assessment (EA), the draft EIS or EA shall be reviewed and used as the basis for findings to comply with the following criteria:
    - i. The project is designed to be compatible with existing land use and social patterns, including noise generation, safety, and zoning.
    - ii. The project is designed to minimize avoidable environmental impacts to identified wetlands, wildlife habitat, air and water quality, cultural resources, and scenic qualities.
    - iii. The project preserves or improves the safety and function of the facility through access management, traffic calming, or other design features.
    - iv. The project includes provision for bicycle and pedestrian circulation as consistent with the Comprehensive Plan and other requirements of this ordinance.
  - b. If review under this section indicates that the use or activity is not clearly authorized by the Transportation System Plan or this ordinance, a plan amendment shall be undertaken prior to or in conjunction with the conditional use permit review. (Ord. 1043 Section 3, 2000)

***Findings:*** *The proposed development meets or exceeds these Required Conditions. SE 1<sup>st</sup> Ave and S Walnut st. will be improved along the property frontages in compliance with the City development / design standards.*

### **16.08.140 TEMPORARY VENDOR.**

Any person who exhibits goods or services for sale or for offer in a temporary manner on private property, from a vehicle, trailer, tent, canopy, shipping container, or other temporary structure, or from one's person or displayed on the ground or off the ground, shall first obtain permit approval in compliance with the following standards, and shall operate in compliance with this section and with all other applicable sections of the Canby Municipal Code.

A. Exemptions. The following temporary activities do not require a Temporary Vendor permit, and are exempt from the standards in this section:

1. Any person engaged in the mere delivery of any goods or services to a site, which were purchased from a regular place of business inside or outside the city;
2. Any person engaged in delivery, exhibition, sale or offering of food on a site for a period of time not to exceed 2 hours during any 24 hour period;
3. Any contractor who is engaged in constructing, maintaining, or repairing a structure, utility, equipment, or landscaping on a site; or
4. Any person conducting a garage sale per Section 5.04.020.

B. Permit process.

1. A request for a Temporary Vendor permit shall be processed as a Type I decision pursuant to the procedures set forth in Chapter 16.89. A Temporary Vendor permit applicant shall demonstrate that the proposed activity meets all fire and life safety codes, and is in compliance with this section and with all other applicable sections of the Canby Municipal Code.
2. An application for a Temporary Vendor permit shall include a site plan drawn to scale, which includes all existing lot lines, setbacks, structures, landscaped areas, paved areas, and parking and loading spaces; and illustrates the proposed location and layout of all the Temporary Vendor's structures, equipment, furnishings, signage, and inventory.
3. The Temporary Vendor activity (e.g., retail, restaurant, etc) shall be an outright permitted use in the zoning district in which it is located; Or if the use is conditionally permitted in the zoning district, a Conditional Use Permit approval shall be required prior to issuance of a Temporary Vendor permit.
4. A "Site and Design Review" permit is not required for a permitted Temporary Vendor.
5. Any signage displayed by the Temporary Vendor must be in compliance with Chapter 16.42 sign standards, and all required Sign permits must be obtained.

6. A Temporary Vendor must obtain a City of Canby business license.
- C. Duration. A Temporary Vendor permit may be granted for a site for up to 90 consecutive calendar days, and then may be renewed twice upon request for an additional 90 days, provided that the temporary vendor activity has been conducted in compliance with all applicable codes, and no public safety incidents have occurred on the site related to the temporary vendor activity. In no case shall a site be permitted to host Temporary Vendor activity for more than 270 days in any 12 month period.
  - D. A Temporary Vendor shall be located on a paved surface with adequate vehicular and pedestrian ingress and egress, in compliance with Section 16.10.070. Inventory and equipment shall not be displayed or stored in any landscaped areas.
  - E. A Temporary Vendor shall comply with all required development standards, such as height limitations, setbacks, vision clearance areas, and applicable conditions of any previous land use decisions for the site.
  - F. Equipment such as trash cans, fuel tanks, or generators shall be screened such that it is not visible from any abutting public right-of-way.
  - G. A Temporary Vendor shall not displace any vehicle parking spaces that are required to meet the minimum off-street parking requirements of another use on site or on a nearby site. A Temporary Vendor shall not encroach into required loading space areas, driveways, or vehicle maneuvering areas.
  - H. A Temporary Vendor that displaces one or more vehicle parking spaces is prohibited for any site that:
    1. Is non-conforming in terms of meeting minimum required vehicle parking or loading space requirements; or
    2. Has been granted a vehicle parking exception, and currently has less than the required minimum number of off-street vehicle parking spaces.
  - I. The property owner and the temporary vendor permit holder shall be jointly and separately responsible for any violation of this section or other applicable sections of the Canby Municipal Code. Any such violation may result in the immediate revocation or non-renewal of a temporary vendor permit, and may result in the denial of any future temporary vendor permit for the site upon which the violation occurred. (Ord 1315, 2009; Ord. 1520, 2019)

**Findings:** *This criterion does not apply to this project. The proposed development does not include any proposed Temporary Vendors as identified by this section.*

**16.08.150 TRAFFIC IMPACT STUDY (TIS).**

- A. Purpose. The purpose of this section of the code is to implement Section 660-012- 0045(2)(b) of the State Transportation Planning Rule, which requires the city to adopt a process to apply conditions to development proposals in order to minimize adverse impacts to and protect transportation facilities. This section establishes the standards to determine when a proposal must be reviewed for potential traffic impacts; when a Traffic Impact Study must be submitted with a development application in order to determine whether conditions are needed to minimize impacts to and protect transportation facilities: what information must be included in a Traffic Impact Study; and who is qualified to prepare the Study.
- B. Initial scoping. During the pre-application conference, the city will review existing transportation data to determine whether a proposed development will have impacts on the transportation system. It is the responsibility of the applicant to provide enough detailed information for the city to make a determination. If the city cannot properly evaluate a proposed development's impacts without a more detailed study, a transportation impact study (TIS) will be required to evaluate the adequacy of the transportation system to serve the proposed development and determine proportionate mitigation of impacts. If a TIS is required, the city will provide the applicant with a "scoping checklist" to be used when preparing the TIS.
- C. Determination. Based on information provided by the applicant about the proposed development, the city will determine when a TIS is required and will consider the following when making that determination.
1. Changes in land use designation, zoning designation, or development standard.
  2. Changes in use or intensity of use.
  3. Projected increase in trip generation.
  4. Potential impacts to residential areas and local streets.
  5. Potential impacts to priority pedestrian and bicycle routes, including, but not limited to school routes and multimodal street improvements identified in the TSP.
  6. Potential impacts to intersection level of service (LOS).
- D. TIS General Provisions
1. All transportation impact studies, including neighborhood through-trip and access studies, shall be prepared and certified by a registered Traffic or Civil Engineer in the State of Oregon.
  2. Prior to TIS scope preparation and review, the applicant shall pay to the city the fees and deposits associated with TIS scope preparation and review in accordance with the adopted fee schedule. The city's costs associated with TIS scope preparation and

review will be charged against the respective deposits. Additional funds may be required if actual costs exceed deposit amounts. Any unused deposit funds will be refunded to the applicant upon final billing.

3. For preparation of the TIS, the applicant may choose one of the following:
    - a. The applicant may hire a registered Oregon Traffic or Civil Engineer to prepare the TIS for submittal to the city. The city Traffic Engineer will then review the TIS and the applicant will be required to pay to the city any fees associated with the TIS review; or
    - b. The applicant may request that the city Traffic Engineer prepare the TIS. The applicant will pay to the city any fees associated with preparation of the TIS by the city Traffic Engineer.
  4. The TIS shall be submitted with a concurrent land use application and associated with application materials. The city will not accept a land use application for process if it does not include the required TIS.
  5. The city may require a TIS review conference with the applicant to discuss the information provided in the TIS once it is complete. This conference would be in addition to any required pre-application conference. If such a conference is required, the city will not accept the land use application for processing until the conference has taken place. The applicant shall pay the TIS review conference fee at the time of conference scheduling, in accordance with the adopted fee schedule.
  6. A TIS determination is not a land use action and may not be appealed.
- E. TIS Scope. The city shall determine the study area, study intersections, trip rates, traffic distribution, and required content of the TIS based on information provided by the applicant about the proposed development.
1. The study area will generally comprise an area within a ½-mile radius of the development site. If the city determines that development impacts may extend more than ½ mile from the development site, a larger study area may be required. Required study intersections will generally include (in addition to the primary access points) collector/collector and above intersections with an anticipated peak hour traffic increase of five-percent from the proposed project.
  2. If notice to ODOT or other agency is required pursuant to noticing requirements in Chapter 16.89, the city will coordinate with those agencies to provide a comprehensive TIS scope. ODOT may also require a TIS directly to support an OR 99E approach permit application.

- F. TIS Content. A project-specific TIS checklist will be provided to the applicant by the city once the city has determined the TIS scope. A TIS shall include all of the following elements, unless waived by the city.
1. Introduction and Summary. This section shall include existing and projected trip generation including vehicular trips and mitigation of approved development not built to date; existing level and proposed level of service standard for city and county streets and volume to capacity for state roads; project build year and average growth in traffic between traffic count year and build year; summary of transportation operations; traffic queuing and delays at study area intersections; and proposed mitigation(s).
  2. Existing Conditions. This section shall include a study area description, including information about existing study intersection level of service.
  3. Impacts. This section should include the proposed site plan, evaluation of the proposed site plan, and a project-related trip analysis. A figure showing the assumed future year roadway network (number and type of lanes at each intersection) also shall be provided. For subdivision and other developments, the future analysis shall be for the year of proposed site build-out. For proposed comprehensive plan and/or zoning map amendments, the future analysis year shall be 20 years from the date of the City's adopted TSP, or 15 years, whichever is greater.
  4. Mitigation. This section shall include proposed site and area-wide specific mitigation measures. Mitigation measures shall be roughly proportional to potential impacts. See Subsection K below for rough proportionality determination.
  5. Appendix. This section shall include traffic counts, capacity calculations, warrant analysis, and any other information necessary to convey a complete understanding of the technical adequacy of the TIS.
- G. TIS Methodology. The City will include the required TIS methodology with the TIS scope.
- H. Neighborhood Through-Trip Study. Any development projected to add more than 30 through-vehicles in a peak hour or 300 through-vehicle per day to an adjacent residential local street or neighborhood route will be require assessment and mitigation of residential street impacts. Through-trips are defined as those to and from a proposed development that have neither an origin nor a destination in the neighborhood. The through-trip study may be required as a component of the TIS or may be a stand-alone study, depending on the level of study required in the scoping checklist. The through-trip study shall include all of the following:
1. Existing number of through-trips per day on adjacent residential local streets or neighborhood routes.

2. Projected number of through-trips per day on adjacent residential local streets or neighborhood routes that will be added by the proposed development.
3. Traffic management strategies to mitigate for the impacts of projected through-trip consistent.

If a residential street is significantly impacted, mitigation shall be required. Thresholds used to determine if residential streets are significantly impacted are:

1. Local residential street volumes should not increase above 1,200 average daily trips
  2. Local residential street speeds should not exceed 28 miles per hour (85th percentile speed).
- I. Mitigation. Transportation impacts shall be mitigated at the time of development when the TIS identifies an increase in demand for vehicular, pedestrian, bicycle, or transit transportation facilities within the study area. Mitigation measures may be suggested by the applicant or recommended by ODOT or Clackamas County in circumstances where a state or county facility will be impacted by a proposed development. The city shall determine if the proposed mitigation measures are adequate and feasible. ODOT must be consulted to determine if improvements proposed for OR 99E comply with ODOT standards and are supported by ODOT. The following measures may be used to meet mitigation requirements:
1. On-and off-site improvements beyond required standard frontage improvements.
  2. Development of a transportation demand management program.
  3. Payment of a fee in lieu of construction, if construction is not feasible.
  4. Correction of off-site transportation deficiencies within the study area that are substantially exacerbated by development impacts.
  5. Construction of on-site facilities or facilities located within the right-of-way adjoining the development site that exceed minimum required standards and that have a transportation benefit to the public.
- J. Conditions of Approval. The city may deny, approve, or approve with appropriate conditions a development proposal in order to minimize impacts and protect transportation facilities.
1. Where the existing transportation system will be impacted by the proposed development, dedication of land for streets, transit facilities, sidewalks, bikeways, paths, or accessways may be required to ensure that the transportation system is adequate to handle the additional burden caused by the proposed use.



2. Where the existing transportation system is shown to be burdened by the proposed use, improvements such as paving, curbing, installation or contribution to traffic signals, traffic channelization, construction of sidewalks, bikeways, accessways, paths, or street that serve the proposed use may be required.
  3. The city may require the development to grant a cross-over access easement(s) to adjacent parcel(s) to address access spacing standards on arterials and collector roadways or site-specific safety concerns. Construction of shared access may be required at the time of development if feasible, given existing adjacent land use. The access easement must be established by deed.
- K. Rough Proportionality Determination. Improvements to mitigate impacts identified in the TIS shall be provided in rough proportion to the transportation impacts of the proposed development.
1. The TIS shall include information regarding how the proportional share of improvements was calculated, using the ratio of development trips to growth trips and the anticipated cost of the full Canby Transportation System Plan. The calculation is provided below:

Proportionate Share Contribution =  $[\text{Net New Trips} / (\text{Planning Period Trips} - \text{Existing Trips})] \times \text{Estimated Construction Cost}$ .

- a. Net new trips means the estimated number of new trips that will be created by the proposed development within the study area.
- b. Planning period trips means the estimated number of total trips within the study area within the planning period identified in the TSP.
- c. Existing trips means the estimated number of existing trips within the study area at the time of TIS preparation.
- d. Estimated construction cost means the estimated total cost of construction of identified improvements in the TSP. (Ord 1340, 2011)

**Findings:** *The proposed development will satisfy the requirements of this code section and incorporate recommendations provided by the traffic impact study. The completed Traffic Impact Study is included with this submittal.*

### **16.08.160 SAFETY AND FUNCTIONALITY STANDARDS.**

The City will not issue any development permits unless the proposed development complies with the city's basic transportation safety and functionality standards, the purpose of which is to ensure that development does not occur in areas where the surrounding public facilities are inadequate. Upon submission of a development permit application, an applicant shall demonstrate that the development property has or will have the following:

- A. Adequate street drainage, as determined by the city.

***Findings:*** *The proposed development meets or exceeds these Required Conditions. The proposed development includes design for adequate street drainage with sediment manholes and drywells as requested by the City of Canby operations group.*

- B. Safe access and clear vision at intersections, as determined by the city.

***Findings:*** *The proposed development meets or exceeds these Required Conditions. The proposed development includes site distance reviews with landscape and site design features located to provide safe and clear vision at entrances and exits.*

- C. Adequate public utilities, as determined by the city.

***Findings:*** *The proposed development meets or exceeds these Required Conditions. The proposed development includes the design and extension of public utilities that will adequately serve the subject project and provide services for future neighboring developments.*

- D. Access onto a public street with the minimum paved widths as stated in Subsection E below.

***Findings:*** *The proposed development meets or exceeds these Required Conditions. The proposed development includes design of half street improvements to meet the City Design Standards.*

- E. Adequate frontage improvements as follows:

1. For local streets and neighborhood connectors, a minimum paved width of 16 feet along the site's frontage.

***Findings:*** *The proposed development will include completion of the half street improvements along S. Walnut street to provide an overall paved street width of 32ft.*

2. For collector and arterial streets, a minimum paved width of 20 feet along the site's frontage.

***Findings:*** *The proposed development will include half street improvements along SE 1<sup>st</sup> Ave. to provide an overall paved street width of 36ft. The existing paving along this stretch of road is being improved as part of the neighboring Shakespeare development and includes reconstruction of the existing 22ft wide roadway. This development will expand the existing roadway with an additional 14ft of paving along the property frontage.*

3. For all streets, a minimum horizontal right-of-way clearance of 20 feet along the site's frontage.

***Findings:*** *The proposed development meets or exceeds these Required Conditions. The proposed development includes design of half street improvements and ROW dedications to provide 37ft of ROW along SE 1<sup>st</sup> Ave and 28ft of ROW along S Walnut St.*

- F. Compliance with mobility standards identified in the TSP. If a mobility deficiency already exists, the development shall not create further deficiencies. (Ord 1340, 2011)

***Findings:*** *The proposed development meets or exceeds these Required Conditions. Sidewalks with ADA ramps will be provided with the proposed street improvements to mitigate existing mobility deficiencies along the frontage of the development.*

## **CHAPTER 16.10 OFF-STREET PARKING AND LOADING**

### **16.10.10 OFF-STREET PARKING REQUIRED – EXCEPTIONS.**

- A. At the time of establishment of a new structure or use, change in use, or change in use of an existing structure, within any planning district of the city, off-street parking spaces and off-street loading berths shall be as provided in this and following sections, unless greater requirements are otherwise established by the conditional use permit or the site and design review process, based upon clear and objective findings that a greater number of spaces are necessary at that location for protection of public health, safety and welfare. A lesser number of spaces may be permitted by the Planning Commission based on clear and objective findings that a lesser number of parking spaces will be sufficient to carry out the objective of this section.

***Findings:*** *The proposed development will meet or exceed the parking requirements of this section.*

- B. No off-street parking shall be required for any use permitted outright within the C-1 zone in the rectangular area bounded by N. Ivy Street on the east, NW First Avenue on the south, N. Elm Street on the west, and NW Third Avenue on the north.

***Findings:*** *This exception does not apply to this project. The proposed development does not lie within the C-1 zone.*

- C. At the time of enlargement of an existing structure or use, the provisions of this section shall apply to the enlarged structure or use only. (Ord. 1304, 2009; Ord. 1237, 2007; Ord. 890 section 9, 1993; Ord. 872, 1992; Ord. 854 section 2, 1991; Ord. 848, Part V, section 1, 16.10.010(A)(B), 1990)

***Findings:*** *This exception does not apply to this project. The proposed development does not contain existing structures.*

### 16.10.20 DEFINITIONS.

- A. Floor Area. Except where otherwise specified, the floor area measured shall be the gross floor area of the building primary to the function of the particular use of the property other than space devoted to off-street parking or loading.
- B. Employees. Where employees are specified, the term shall apply to all persons, including proprietors, working on the premises during the peak shift. (Ord. 854 section 2, 1991; Ord. 848, Part V, section 1, 16.10.020(A)(B), 1990)

### 16.10.30 GENERAL REQUIREMENTS.

- A. Should the owner or occupant of a structure change the use to which the building is put, thereby increasing parking or loading requirements, the increased parking/loading area shall be provided prior to commencement of the new use.

***Findings:*** *This criterion does not apply to this project. Sufficient parking is provided to accommodate the anticipated light industrial uses being considered with this development. Any future change in use will conform to the requirements of this section.*

- B. Parking and loading requirements for structures not specifically listed herein shall be determined by the City Planner, based upon requirements of comparable uses listed.

***Findings:*** *The proposed development meets or exceeds these Required Conditions. Parking and loading requirements for light industrial uses to include manufacturing and warehouse with ancillary office are noted on the site plan.*

- C. In the event several uses occupy a single structure, the total requirements for off-street parking shall be the sum of the requirements of the several uses computed separately. If the applicant can demonstrate that the uses do not have overlapping parking needs (based on days and hours of operation) and can share parking, the total requirement for combined uses may be reduced by up to 60 percent.

***Findings:*** *The proposed development meets or exceeds these Required Conditions. The proposed development will calculate required parking minimums utilizing anticipated light industrial uses including warehouse and manufacturing with ancillary office.*

- D. Off-street parking spaces for dwellings shall be located on the same lot, or adjacent lot, with the dwelling. Parking spaces located within an on-site garage shall count toward the minimum parking requirement for residential uses. Other required parking spaces may be located on a separate parcel, provided the parcel is not greater than five hundred (500) feet from the entrance to the building to be served, measured along the shortest pedestrian route to the building. The applicant must prove that the parking located on another parcel is functionally located and that there is safe vehicular and pedestrian access to and from the site.

***Findings:*** *This criterion does not apply to this project. The proposed development does not contain any proposed dwellings.*

- E. Required parking spaces shall be available for the parking of operable passenger automobiles of residents, customers, patrons and employees and shall not be used for storage of vehicles or materials or for the parking of trucks used in conducting the business.

***Findings:*** *The proposed development meets or exceeds these Required Conditions. The proposed development will ensure that required parking spaces will remain available for the parking of operable passenger autos, customer vehicles and that required spaces for patrons and employees shall not be used for storage of vehicles or materials or for the parking of trucks used in conducting the business.*

- F. Institution of on-street parking shall not be allowed for off-street parking, where none is previously provided, and shall not be done solely for the purpose of relieving crowded parking lots in commercial or industrial planning districts.

***Findings:*** *This criterion does not apply to this project. The proposed development does not propose the use of on-street parking.*

- G. Parking facilities may be shared by users on adjacent parcels if all of the following standards are met, or the Planning Commission determines a lesser combination meets the intent of the ordinance:
  - 1. One of the parcels has excess parking spaces, considering the present use of the property; and the other parcel lacks sufficient area for required parking spaces. Excess parking spaces can be determined by considering when the uses need the parking spaces, such as time of day or day of week.
  - 2. The total number of parking spaces meets the standards for the sum of the number of spaces that would be separately required for each use. If the applicant can demonstrate that the uses do not have overlapping parking needs (based on days and hours of operation) and can share parking, the total requirement for combined uses may be reduced by up to 60 percent.
  - 3. Legal documentation, to the satisfaction of the City Attorney, shall be submitted verifying present use of the excess parking area on one lot by patrons of the uses deficient in required parking areas.
  - 4. Physical access between adjoining lots shall be such that functional and reasonable access is provided to uses on the parcel deficient in parking spaces.
  - 5. Adequate directional signs shall be installed specifying the joint parking arrangement.

***Findings:*** *This criterion does not apply to this project. The proposed development does not propose to share parking facilities with the adjacent parcels.*

H. The number of vehicular spaces required in Table 16.10.050 may be reduced by up to 10% if one of the following is demonstrated to the satisfaction of the Planning Director or Planning Commission:

1. Residential densities greater than nine units per gross acre (limit parking to no less than one space per unit for multi-family structures); or
2. The proposed development is pedestrian-oriented by virtue of a location which is within convenient walking distance of existing or planned neighborhood activities (such as schools, parks, shopping, etc.) and the development provides additional pedestrian amenities not required by the code which, when taken together, significantly contribute to making walking convenient (e.g., wider sidewalks, pedestrian plazas, pedestrian scale lighting, benches, etc.). (Ord. 890 section 10, 1993; Ord. 854 section 2 [part], 1991; Ord. 848, Part V, section 16.10.030, 1990; Ord. 1043 section 3, 2000; Ord. 1338, 2010)

**Findings:** *This criterion does not apply to this project. The proposed development does not propose any reductions to the minimum required number of parking spaces.*

**16.10.040 PROHIBITED NEAR INTERSECTIONS.**

In no case will off-street parking be allowed within a vision clearance area of an intersection. (Ord. 740 section 10.3.10(D), 1984)

**Findings:** *This criterion does not apply to this project. The proposed development does not propose the use of on-street parking.*

**16.10.050 PARKING STANDARDS DESIGNATED.**

The parking standards set out in Table 16.10.050 shall be observed. (Ord. 854 section 2, [part], 1991; Ord. 848 section 1, 16.10.050, 1990; Ord. 740 section 10.3.10(E), 1984; Ord. 981 section 20, 1997)

**TABLE 16.10.050**

Off-street Parking Provisions - The following are the minimum standards for off-street vehicle parking:

USE	PARKING REQUIREMENT
<b>Residential Uses:</b>	
a. Single-family dwellings	2.00 spaces per dwelling unit for new construction. (Existing single-family dwellings having only a single parking space shall not be considered to be nonconforming.)
b. Two-family dwellings	2.00 spaces per dwelling unit.
c. Multi-family dwellings in complexes with private internal driveways	One space per studio or 1-bedroom unit. 2.00 spaces per 2-bedroom or larger unit. One additional guest parking space shall be provided for every five units for each development often or more units.

d. Retirement/assisted living	1.0 spaces per unit
e. Residential day care facility and	1.00 space per employee
<b>Institutions:</b>	
a. Convalescent home, nursing home or sanitarium	1.00 spaces per two beds for patients or residents, plus 1.00 space per employee
b. Hospital	4.00 spaces per two beds
<b>Places of Public Assembly:</b>	
a. Library, reading room	1.00 space per 400 square feet of public area
b. Nursery, primary/elementary, or junior high school	2.00 spaces per employee
c. Senior high school	1.00 space per classroom, plus 1.00 space per six students
d. Other places of public assembly, including churches	1.00 space per four seats or eight feet of bench length
<b>Commercial Amusement:</b>	
a. Theater	1.00 per six seats
b. Bowling alley	3.0 spaces per 1,000 square feet of floor area
c. Dance hall, skating rink	3.0 spaces per 1,000 square feet of floor area
d. Racquet courts, health clubs	3.0 spaces per 1,000 square feet of floor area
<b>Commercial</b>	
a. Retail shops (under 100,000 sq. ft.)	2.00 spaces per 1,000 square feet of floor area
b. Retail store handling exclusively bulky merchandise such as furniture, automobile and service repair shops	1.00 space per 1,000 square feet of sales floor area
c. Shopping center (over 100,000 square feet of gross leasable area)	3.00 spaces per 1,000 square feet of gross leasable area
d. Banks/savings and loans	2.00 spaces per 1,000 gross square feet of floor area
e. Medical/dental offices	3.00 spaces per 1,000 gross square feet of floor area
f. General offices	2.00 spaces per 1,000 gross square feet of floor area
g. Real estate offices	2.00 spaces per 1,000 gross square feet of floor area
h. Government offices	3.50 spaces per 1,000 gross square feet of floor area
i. Restaurant	8.00 spaces per 1,000 gross square feet of floor area
j. Take-out restaurant	8.00 spaces per 1,000 gross square feet of floor area
k. Motel	0.75 spaces per rentable room
l. Residential hotel, rooming house,	0.75 spaces per rentable room
m. Hotel	0.75 spaces per rentable room
n. Club or lodge	1.00 space per 200 square feet of floor area
o. Day care , adult or child care; does not include Family Daycare (12 or fewer children) under ORS	1.00 space per 500 square feet of floor area



657A.250	
p. All others	1.00 space per 550 square feet
q. Wireless telecommunication systems	1.00 space per site
r. Self-Storage (Mini) Warehouse	2.00 spaces per 1,000 gross square feet of office space
<b>Industrial:</b>	
a. Manufacturing	2.00 spaces per 1,000 gross square feet of office space, plus 1.00 space per 1,000 gross square feet of non-office manufacturing space. Minimum of 5 parking spaces overall.
b. Warehousing	2.00 spaces per 1,000 gross square feet of office space, plus 1.00 space per 1,000 gross square feet of non-office warehousing space. Minimum of 5 parking spaces overall.
c. Wholesale establishments	2.00 spaces per 1,000 gross square feet of office space, plus 1.50 spaces per 1,000 gross square feet of non-office wholesale space. Minimum of 5 parking spaces overall.

(Ord 1296, 2008, Ord. 1338, 2010; Ord. 1514, 2019)

**Findings:** *The proposed development meets or exceeds these Required Conditions. The proposed development will calculate parking using warehouse/manufacturing as the primary use with accessory office as listed in the above table.*

**16.10.60 OFF-STREET LOADING FACILITIES**

A. The minimum number of off-street loading berths for commercial and industrial uses is as follows:

SQUARE FEET OF FLOOR AREA	NUMBER OF BERTHS
Less than 5,000	0
5000 – 25,000	1
25,000 – 60,000	2
60,000 and over	3

**Findings:** *The proposed development exceeds these Required Conditions and includes a total of 87 loading berths.*

B. Loading berths shall conform to the following minimum size specifications:

1. Commercial uses – 13’ x 35’
2. Industrial uses – 12’ x 60’

3. Berths shall have an unobstructed minimum height of 14'.

***Findings:*** *The proposed development exceeds these Required Conditions.*

- C. Required loading areas shall be screened from public view, from public streets, and adjacent properties by means of sight-site obscuring landscaping, walls or other means, as approved through the site and design review process.

***Findings:*** *The proposed development meets these Required Conditions. The landscape setback at the SE 1<sup>st</sup> Ave frontage and the landscape island extensions which separate the vehicle access drive and parking areas from the truck yard will be planted with dense evergreen plantings to obscure the truck court from the street. Additional landscape buffer plantings have been added in the street setbacks in proximity of the truck courts.*

- D. Required loading facilities shall be installed prior to final building inspection and shall be permanently maintained as a condition of use.

***Findings:*** *The proposed development meets or exceeds these Required Conditions. The proposed loading facilities will be installed prior to final building inspection and will be permanently maintained.*

- E. A driveway designed for continuous forward flow of passenger vehicles for the purpose of loading and unloading children shall be located on the site of a school or day care center having a capacity greater than twenty-five (25) students.

***Findings:*** *This criterion does not apply to this project. The proposed development does not propose any schools or daycare centers.*

- F. The off-street loading facilities shall, in all cases, be on the same lot or parcel as the structure they are intended to serve. In no case shall the required off-street loading spaces be part of the area used to satisfy the off-street parking requirement.

***Findings:*** *The proposed development meets or exceeds these Required Conditions. The proposed loading facilities are designed to be located adjacent to the building on the site and clear of the on-site parking lot.*

- G. The Planning Commission may exempt a building from the loading berth requirement, or delay the requirement, based on findings that loading berths are not needed for a particular building or business. (Ord. 854 section 2[part], 1991; Ord. 848, Part V, section 1, 16.10.060, 1990; Ord. 1237, 2007)

***Findings:*** *This exception is not needed. The proposed development meets or exceeds the required loading berth requirements.*

### **16.10.70 PARKING LOTS AND ACCESS.**

A. Parking Lots. A parking lot, whether as accessory or principal use, intended for the parking of automobiles or trucks, shall comply with the following:

1. Parking lot design shall comply with the dimensional standards set forth in Figure 1 of this section.

***Findings:*** *The proposed development meets or exceeds these Required Conditions. The proposed development has designed the parking lot to comply with the dimensional standards outlined in figure 1 and Table 16.10.070 of this section.*

2. Parking stalls of eight (8) feet in width and sixteen (16) feet in length for compact vehicles may comprise up to a maximum of thirty (30) percent of the total number of parking stalls. Such parking stalls shall be marked "Compact Parking only" either on the parking surface or on a sign in front of the parking stalls.

***Findings:*** *This criterion does not apply to this project. The proposed development does not propose any compact parking spaces.*

3. Areas used for staging or maneuvering of vehicles shall have paved asphalt, concrete, solid concrete paver surfaces, or paved "tire track" strips maintained adequately for all weather use and so drained as to avoid the flow of water across sidewalks or into public streets, with the following exception:

***Findings:*** *The proposed development meets or exceeds these Required Conditions. The proposed development has designed the parking lot to be fully paved with asphalt throughout the auto parking/drives and within the truck courts with concrete aprons provided at the loading docks.*

- a. The Planning Director or Planning Commission may approve the use of an engineered aggregate system for outdoor storage and/or non-required parking areas provided that the applicant can demonstrate that City Standards related to:
  - i. minimizing dust generation,
  - ii. minimizing transportation of aggregate to city streets, and
  - iii. minimizing infiltration of environmental contaminants including, but not limited to, motor oils, fuels, volatile organic compounds (e.g. benzene, toluene, ethylbenzene, xylene), and ethylene glycol are met.

The decision maker may impose conditions as necessary to meet City Standards.

**Findings:** *This criterion does not apply to this project. The proposed development does not propose any engineered aggregate systems.*

- b. Use of permeable surfacing materials for parking lots and driveways is encouraged whenever site and soil conditions make permeable surfacing feasible. Permeable surfacing includes, but is not limited to: paving blocks, turf block, pervious concrete, and porous asphalt. All permeable surfacing shall be designed, constructed, and maintained in accordance with the Canby Public Works Design Standards and the manufacturer's recommendations. Maintenance of permeable surfacing materials located on private property are the responsibility of the property owner.

**Findings:** *The near surface soils on the site have negligible infiltration capabilities which would render any proposed permeable surfacing unfeasible. All surface water will be collected and filtered through an approved storm water quality system prior to being retained on-site. Storm water retention will include a combination of dry wells and storm chamber systems installed at the depth of the dense gravel which occurs 20-30ft below grade.*

4. The full width of driveways must be paved in accordance with (3) above:
  - a. For a minimum of 20 feet from the right-of-way line back into the private property to prevent debris from entering public streets, and
  - b. To within 150 feet of all portions of the exterior wall of the first story of any structure(s) served by the driveway to ensure fire and emergency service provision.

**Findings:** *The proposed development meets or exceeds these Required Conditions. The proposed development has designed the driveways to be paved with concrete and asphalt to the full width and depth exceeding the requirements outlined in this section.*

5. Except for parking to serve residential uses, parking areas adjacent to or within residential planning districts or adjacent to residential uses shall be designed to minimize disturbance of residents. Artificial lighting, which may be provided, shall be so deflected as not to shine or create glare in any residential planning district or on any adjacent dwelling, or any street right-of-way in such a manner as to impair the use of such way.

**Findings:** *This criterion does not apply to this project. The proposed development is not adjacent to a residential planning district or use. The parking areas have been located throughout the site to provide convenient access to the proposed office areas and to minimize maneuvering conflicts with truck traffic. As required by the applicable design standards, evergreen landscape screening is being provided in front of the parking stalls to minimize headlight glare onto the neighboring properties. The parking areas will be illuminated with a*

*combination of the street lighting required with the ROW improvements and wall mounted lighting on the buildings.*

6. Groups of more than four (4) parking spaces shall be so located and served by driveways that their use will require no backing movements or other maneuvering within a street right-of-way other than an alley.

***Findings:*** *The proposed development meets or exceeds these Required Conditions. The proposed development has designed the parking lot as to not require backing movements within a street right-of-way.*

7. Off-street parking areas, and the accesses to them, shall be designed and constructed to facilitate the flow of traffic, provide maximum safety of traffic access and egress and the maximum safety of pedestrian and vehicular traffic on the site and in adjacent roadways. The Planning Director or Planning Commission may require engineering analysis and/or truck turning diagrams to ensure safe and efficient traffic flow based on the number and type of vehicles using the site, the classification of the public roadway, and the design of the parking lot and access drives.

***Findings:*** *The proposed development meets or exceeds these Required Conditions. To the extent possible, the access drives, pedestrian connections, auto parking and truck staging/loading areas have been located to provide safe ingress/egress throughout the development. The truck driveways have been widened to 50ft to provide safe and efficient maneuvering into/out of the truck courts and to minimize turning/staging conflicts. Directional signage will be provided at the driveways denoting 'truck' or 'auto' entrances.*

8. Parking bumpers or wheel stops shall be provided to prevent cars from encroaching on the street right-of-way, adjacent landscaped areas, or adjacent pedestrian walkways.

***Findings:*** *The proposed development meets or exceeds these Required Conditions. The proposed development has designed the parking facilities to include the use of parking bumpers to prevent cars from encroaching on the adjacent landscaped areas or adjacent pedestrian walkways. No parking is proposed along the right-of-way that would require such provisions.*

9. Accessible parking shall be provided, constructed, striped, signed and maintained as required by ORS 447.233 and all Oregon Structural Specialty Code requirements.

***Findings:*** *The proposed development meets or exceeds these Required Conditions. The proposed development has designed the accessible parking to meet the requirements of ORS 447.233 and all Oregon Structural Specialty Code requirements.*

**TABLE 16.10.070**  
**Minimum dimensional Standard for Parking**

This table and Figure 16.10.070 provide the minimum dimensional standards for parking areas and spaces.

A = Parking angle in degrees  
B = Minimum stall width  
C = Minimum stall depth

D = Minimum clear aisle width  
E = Minimum clear stall distance at bay side  
F = Minimum clear bay width

A	B	C	D	E	F
0 (parallel)	8'0"	-	12'0"	22'0"	20'0"
30	8'6"	16'4"	12'0"	17'0"	28'4"
45	8'6"	18'9"	12'6"	12'0"	31'3"
60	8'6"	19'10"	18'0"	9'10"	37'10"
90	8'6"	18'0"	24'0"	8'6"	42'0"

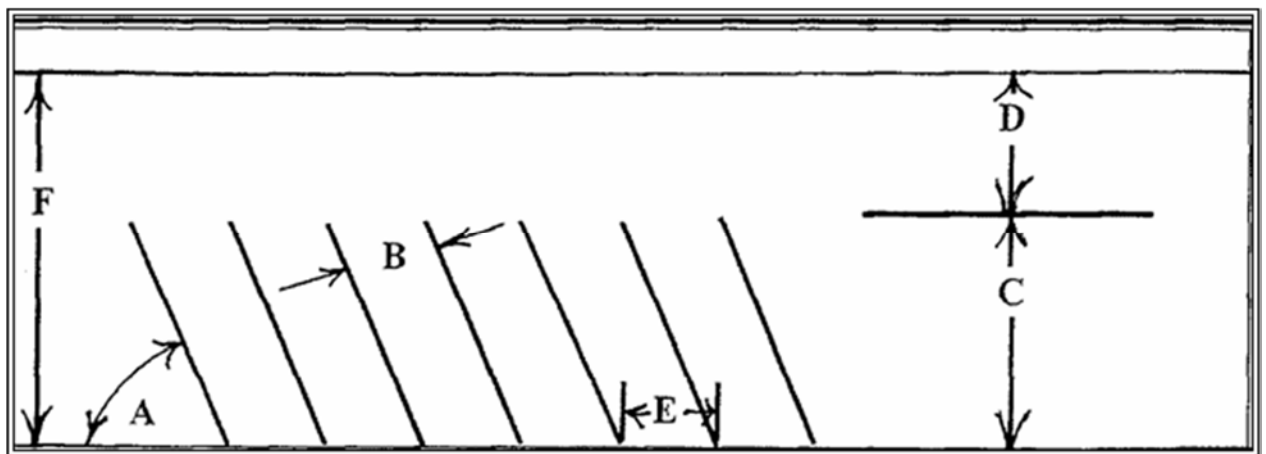

**B. Access**

1. The provision and maintenance of vehicular and pedestrian ingress and egress from private property to the public streets as stipulated in this ordinance are continuing requirements for the use of any structure or parcel of real property in the City of Canby. No building permit or other permits shall be issued until scale plans are presented that show how the ingress and egress requirement is to be fulfilled. Should the owner or occupant of a lot or building change the use to which the lot or building is put, thereby increasing ingress and egress requirements, it shall be unlawful and a violation of this ordinance to begin or maintain such altered use until the required increase in ingress and egress is provided.

**Findings:** *The proposed development meets or exceeds these Required Conditions. With the proposed development, the Engineer will submit design drawings to the City that demonstrate how the requirements of this section will be met. In the event that any modifications are to be made with future development, it is understood that revised drawings would need to be re-submitted and approved as required.*

2. The City of Canby encourages joint/shared access. Owners of two (2) or more uses, structures, or parcels of land may agree to, or may be required by the City to, utilized

jointly the same ingress and egress when the combined ingress and egress of both uses, structures, or parcels of land satisfies their combined requirements as designed in this ordinance, provided that satisfactory legal evidence is presented to the City Attorney in the form of deeds, easements, leases or contracts shall be placed on permanent files with the city recorder.

***Findings:*** *Joint/shared access is proposed for the driveway at Walnut St. which is centered between buildings A&B and for the driveway at SE 1<sup>st</sup> Ave between buildings A&C. Although the developer has had discussions with the neighbors to the south and to the west, they have not agreed to locating shared access drives on the common property lines.*

3. All ingress and egress shall connect directly with public streets.

***Findings:*** *The proposed development meets or exceeds these Required Conditions. The proposed development proposes three (4) ingress/egress driveways connecting the development directly with public streets.*

4. Vehicular access for residential uses shall be brought to within fifty (50) feet of the ground floor entrances or the ground floor landing of a stairway, ramp or elevator leading to dwelling units.

***Findings:*** *This criterion does not apply to this project. The proposed development does not contain any residential uses.*

5. Required sidewalks shall extend from the ground floor entrances or the ground floor landing of a stairs, ramps or elevators to the sidewalk or curb of the public street or streets that provide the required access and egress.

***Findings:*** *The proposed development meets or exceeds these Required Conditions. A total of 5 pedestrian connections are proposed along the street frontages to provide connections to the internal sidewalks and allow for efficient ingress/egress to the primary building entrances. The drive aisle crossings are located at the ends of the parking runs and delineated with striping on the asphalt to provide safe access to the building.*

6. To afford safe pedestrian access and egress for properties within the city, a sidewalk shall be constructed along all street frontages, prior to use or occupancy of the building or structure proposed for said property. The sidewalks required by this section shall be constructed to city standards except in the case of streets with inadequate right-of-way width or where the final street design and grade have not been established, in which case the sidewalks shall be constructed to a design, and in a manner approved by the Site and Design Review Board. Sidewalks approved by Board may include temporary sidewalks and sidewalks constructed on private property; provided, however, that such sidewalks shall provide continuity with sidewalks of adjoining commercial developments existing or proposed. When a sidewalk is to adjoin a future street improvement, the sidewalk construction shall



include construction of the curb and gutter section to grade and alignment established by the Site and Design Review Board.

**Findings:** *The proposed development meets or exceeds these Required Conditions. The proposed development has designed the City sidewalk within the right-of-way to be constructed to meet the City design standards. Per City Comments during the Pre-Application Conference, City sidewalk is to be constructed for the full frontage of the property along SE 1<sup>st</sup> Ave. and S. Walnut St. Curb and gutter will join the sidewalk at both ends, with the sidewalk to be extended with future development of the neighboring parcels (by others).*

- The standards set forth in this ordinance are minimum standards for access and egress, and may be increased through the site and design review process in any particular instance where the standards provided herein are deemed insufficient to protect the public health, safety and general welfare. (Ord. 890 section 12, 1993; Ord. 1237, 2007; Ord. 1338, 2010)

<b>Minimum Access Requirements</b>			
<b>16.10.070(B)(8): Minimum access requirements for residential uses - ingress and egress for residential uses shall not be less than the following (except that in the case of flag lots, section 16.64.0400) shall apply):</b>			
<i>Dwelling units</i>	<i>Minimum number of accesses required</i>	<i>Minimum access width</i>	<i>Sidewalks &amp; Curbs (in addition to driveways)</i>
1 or 2	1	12 feet	none required
3-19	1	20 feet	Minimum of one sidewalk connection to residences and parking areas; curb required if sidewalk adjacent to driveway.
20-49	Option A: 1 access OR Option B: 2 accesses	20 feet  12 feet	Minimum of one sidewalk connection to residences and parking areas; curb required if sidewalk adjacent to driveway.
50-499	Option A: 1 access OR Option B: 2 accesses	30 feet  20 feet	Curbs required; Minimum of one sidewalk connection to residences and parking areas
Over 500	As required by Site and Design Review Board		As required by Public Works Director
<b>16.10.070(B)(9): Minimum access requirements for commercial or institutional uses - ingress and egress for commercial uses shall not be less than the following:</b>			
<i>Parking spaces required</i>	<i>Minimum number of accesses required</i>	<i>Minimum access width</i>	<i>Sidewalks &amp; curbs (in addition to driveways)</i>

1-4	1	12 feet	<i>None required</i>
5-99	1	20 feet	Curbs required; sidewalk on one side minimum
100-249	2	20 feet	Curbs required; sidewalk on one side minimum
Over 250	As required by Site and Design Review Board	As required by Public Works Director	
<b>16.10.070(B)(10): Minimum access requirements for industrial uses - ingress and egress for industrial uses shall not be less than the following:</b>			
<i>Parking spaces required</i>	<i>Minimum number of accesses required</i>	<i>Minimum access width</i>	<i>Sidewalks &amp; curbs (in addition to driveways)</i>
1-250	1	24 feet	Curbs required; sidewalks on one side minimum
Over 250	As required by Public Works Director		

**Findings:** *The proposed development meets or exceeds these Required Conditions. The proposed development includes five (5) access drives with widths greater than 24ft.*

8. One-Way Ingress or Egress – The hard surfaced pavement of one-way drives shall not be less than twelve (12) feet for multi-family residential, commercial or industrial uses. (Ord. 1514, 2019)

**Findings:** *This criteria does not apply. All 5 access drives provide for 2-way access.*

**9. Driveways:**

- a. Access to private property shall be permitted with the use of driveway curb cuts. The access points with the street shall be the minimum necessary to provide access while not inhibiting the safe circulation and carrying capacity of the street. Driveways shall meet all applicable guidelines of the Americans with Disabilities Act (ADA). Driveway distance shall be measured from the curb intersection point [as measured for vision clearance area (16.04.670)]. Distances to an intersection shall be measured from the stop bar at the intersection.

**Findings:** *The proposed development meets or exceeds these Required Conditions. The driveway locations have been designed and located to comply with the City of Canby design standards to include intersection spacing, site distance and width. The driveway widths are 30ft and 50ft respectively for the drives at S. Walnut and SE 1<sup>st</sup> Ave with the wider drives designed to provide safe turning movements without crossing lanes of traffic for the associated industrial truck traffic. ADA approved ramps are included on each side of all driveways.*

- b. Driveways shall be limited to one per property except for certain uses which include large commercial uses such as large box stores, large public uses such as schools and parks, drive through facilities, property with a frontage of over 250-feet and similar uses.

**Findings:** *The proposed development meets or exceeds these Required Conditions. The proposed development includes (4) driveway accesses along the 2000ft of frontage for the 3 parcels. As previously noted, these access drives have been designed and located to accommodate the topographic constraints of the property and to provide safe and efficient maneuvering ingress/egress for the truck, auto, emergency and pedestrian traffic.*

- c. Double frontage lots and corner lots may be limited to access from a single street, usually the lower classification street. Single family residential shall not have access onto arterials, and shall have access onto collectors only if there is no other option.

**Findings:** *As previously noted, the proposed drives have been designed and located to accommodate the topographic constraints of the property and to provide safe and efficient maneuvering ingress/egress for the truck, auto, emergency and pedestrian traffic associated with the development. The partition of the property provides building A with double frontage with building B having frontage at Walnut and building C having frontage at SE 1<sup>st</sup> Ave. Cross access and drive circulation easements will be implemented between the properties to allow for shared use of these common areas. Due to the topographic constraints and access/circulation requirements, orienting the buildings to limit access to the lower classified street at Walnut is not feasible for the planned development.*

- d. If additional driveways are approved by the City Administrator or designee, a finding shall be made that no eminent traffic hazard would result and impacts on through traffic would be minimal. Restrictions may be imposed on additional driveways, such as limited turn movements, shared access between uses, closure of existing driveways, or other access management actions.

**Findings:** *The proposed development meets or exceeds these Required Conditions. The proposed driveways have been designed in accordance with the City design standards, with the approval of the City's planning staff and recommendations outlined in the accompanying Traffic Impact Study. Furthermore, the study demonstrates that traffic hazards will not be created by the proposed drive locations.*

- e. Within commercial, industrial, and multi-family areas, shared driveways and internal access between similar uses are encouraged to reduce the access points to the higher classified roadways, to improve internal site circulation, and to reduce local trips or movements on the street system. Shared driveways or internal access between uses will be established by means of common access easements at the time of development.

**Findings:** Joint/shared access is proposed for the driveway at Walnut St. which is centered between buildings A&B and for the driveway at SE 1<sup>st</sup> Ave between buildings A&C. Although we have had discussions with the neighbors to the south and to the west, they have not agreed to locating shared access drives on the common property lines.

f. Driveway widths shall be as shown on the following table.

<b>Driveway Widths (Minimum/Maximum, Ft.)</b>			
<b>Street Classification</b>	<b>Res.</b>	<b>Comm.</b>	<b>Ind.</b>
<b>Arterial:</b>	NA (1)	12/36	12/36
<b>Industrial:</b>	NA (1)	12/36	12/36
<b>Collector:</b>	12/24 (2)	12/36	12/36
<b>Neighborhood Route:</b>	12/24 (2)	12/36	12/36
<b>Local:</b>	12/24 (2)	12/36	12/36
<b>Cul-de-sac:</b>	12/24 (2)	12/36	12/36
<b>Public Alley</b>	12/24 (2)	NA	NA

Res. = Residential Zone  
 Comm. = Commercial Zone  
 Ind. = Industrial Zone

- Notes:**
- (1) Special conditions may warrant access.**
  - (2) 28' maximum width for 3-car garage.**

**Findings:** The proposed development proposes to apply for an exception to the minimum driveway width of 36ft along SE 1<sup>st</sup> Avenue. Previous developments in the area, located along similar collector streets have been approved to increase the driveway widths up to the proposed width of 50 feet. This will significantly improve the safety of these drives by reducing truck turning conflicts with vehicles maneuvering into and out of these drives.

g. Driveway spacing shall be as shown in the following table.

**Minimum Driveway Spacing**

<b><u>Street Classification</u></b>	<b><u>Intersection</u></b>	<b><u>Driveway</u></b>
<b>Arterial (2)</b>	330' (1)	330' (1)
<b>Industrial Streets (2)</b>	100' (1)	100' (1)
<b>Collector (2)</b>	100' (1)	100' (1)
<b>Neighborhood Route</b>	50' (1)(3)	10'
<b>Local (all)</b>	50' (1)(3)	10'
<b>Cul-de-sac</b>	50' (1)(3)	10'
<b>Public Alley</b>	50' (1)(3)	

- Notes:**
- (1) Minimum distance or no closer than 60% of parcel frontage unless this prohibits access to the site, in which case City Administrator or designee may approve a deviation.
  - (2) Direct access to this street will not be allowed if an alternative exists or is planned.
  - (3) For single-family residential houses, the minimum distance between driveways and an intersection shall be thirty (30) feet.

**Findings:** *The proposed development meets or exceeds these Required Conditions. The driveways at SE 1<sup>st</sup> Ave. are spaced 480ft apart with the western drive located 325ft from the intersection of SE Hazel Del and the eastern drive located 420ft from S Walnut St. The driveways at S Walnut St. are spaced 443ft apart with the north drive located 400ft from the SE 1<sup>st</sup> Ave intersection and the south drive located 76ft from the neighbors drive to the south.*

- h. Curb cuts shall be a minimum of five feet from the property line, unless a shared driveway is installed. Single driveways may be paved up to an adjacent property line but shall maintain a five (5) foot separation from the side property line where the driveway enters the property. Driveways shall not be constructed within the curb return of a street intersection. Deviations may be approved by the City Administrator or designee.

**Findings:** *The proposed development meets or exceeds these Required Conditions. The shared driveways are centered on the property line whereas the west drive at SE 1<sup>st</sup> and the south drive at S Walnut St. are located in close proximity to the associated property line.*

- i. For roads with a classification of Collector and above, driveways adjacent to street intersections shall be located beyond the required queue length for traffic movements at the intersection. If this requirement prohibits access to the site, a driveway with restricted turn movements may be permitted.

**Findings:** *The proposed development meets or exceeds these Required Conditions. The proposed driveways are located beyond the required queue length for traffic movements at the intersections at SE 1<sup>st</sup> & Hazel Del and S Walnut.*

- j. Multi-family access driveways will be required to meet the same access requirements as commercial driveways if the multi-family site generated 100 or more trips per day.

**Findings:** *This criterion does not apply to this project. The proposed development does not contain any multi-family driveways.*

- k. For circular type driveways, the minimum distance between the two driveway curb cuts on one single-family residential lot shall be thirty (30) feet. (Ord. 1514, 2019)

***Findings:*** *This criterion does not apply to this project. The proposed development does not contain any residential type circular driveways.*

10. When considering a public facilities plan that has been submitted as part of site and design review plan in accordance with this ordinance, the city Public Works Supervisor may approve the location of a driveway closer than fifty (50) feet from the intersection of collector or arterial streets, based on written findings of fact in support of the decision. Said written approval shall be incorporated into the recommended decision of the City Planner for the site and design review plan under the process set forth.

***Findings:*** *This criterion does not apply to this project. The proposed development does not contain any facilities with this application.*

11. Where an existing alley is 20 feet or less in width, the property line setback abutting the alley shall increase to provide a minimum of 24 feet for maneuvering and backing movements from, garages, carports, or parking areas. (Ord. 890 section 12, 1993; Ord. 872, 1991; Ord. 854 section 2 [part], 1991; Ord 848, Part V, section 16.10.070 (A)(B) 1990; Ord. 955 section 3 & 4 1996; Ord. 981 section 44, 1997; Ord. 1019 section 5, 1999; Ord 1237, 2007; Ord. 1514, 2019)

***Findings:*** *This criterion does not apply to this project. The proposed development does not contain an alley.*

#### **16.10.080 STREET TREE PLAN.**

A Street Tree Plan can be provided in lieu of meeting the requirement of planting a tree every 30 lineal feet of street frontage as stated in Ordinance 1385 Exhibit B. The Street Tree Plan can compensate for driveways, utilities, or other obstructions that inhibit the 30 foot spacing requirement. The requirement for the planting of street trees is required under Chapter 12.32 CMC. (Ord. 854, 1991; Ord. 848, Part VI, section 1, 1990; Ord. 1514, 2019)

***Findings:*** *The proposed development meets or exceeds these Required Conditions. The landscaping design submitted with application includes the planting of street trees as required.*

#### **16.10.90 DRIVE-UP USES.**

- A. Drive-up uses shall provide a minimum stacking area clear of the public right-of-way or parking lot aisle from the window service to the vehicles as follows:
  1. All drive-up uses. – Each lane shall provide a minimum capacity for two (2) to eight (8) automobiles, as determined by the Site and Design Review Board.
  2. For purposes of this section, an automobile shall be considered no less than twenty (20) feet in length. The width and turning radius of drive-up aisles shall be approved by the City Public Works Director.

- B. The stacking area shall not interfere with safe and efficient access to other parking areas on the property. Traffic aisles shall be wide enough to accommodate backing movements where adjacent to parking stalls. Parking maneuvers shall not occur in the stacking area. (Ord. 848, Part VII, section 16.10.090, 1990)

**Findings:** *This criterion does not apply to this project. The proposed development does not contain any drive-up uses.*

**16.10.100 BICYCLE PARKING.**

Bicycle parking shall be provided for all multi-family residential, institutional, commercial, and industrial uses.

- A. Dimensions and characteristics: Bicycle parking spaces shall be a minimum of six (6) feet long and two (2) feet wide, and overhead clearance in covered spaces shall be a minimum of seven (7) feet. A minimum five (5) foot aisle for bicycle maneuvering shall be provided and maintained beside or between each row of bicycle parking. Bicycle racks located on a sidewalk shall provide a minimum of two (2) feet between the rack and a wall or other obstacle, and between the rack and curb face. Bicycle racks or lockers shall be securely anchored to the surface or a structure. Bicycle racks located in the Downtown Commercial Zone shall be of the inverted U style (a.k.a. staple racks). See Figure 20 of the Canby Downtown Plan for correct rack placement.

**Findings:** *The proposed development meets or exceeds these Required Conditions. The proposed development includes bicycle racks to be constructed to meet the requirements of this section.*

- B. Location: Bicycle parking shall be located in well-lit, secure locations within fifty (50) feet of the main entrance to a building, but not further from the entrance than the closest automobile parking space, and in no case further than 50 feet from an entrance when several entrances are involved.

**Findings:** *The proposed development meets or exceeds these Required Conditions. The proposed development includes bicycle racks to be constructed near the main entrance to meet the requirements of this section.*

- C. Number of spaces: The bicycle parking standards set out in Table 16.10.100 shall be observed. (Ord. 1019 section 1, 1999; Ord. 1076, 2001)

TABLE 16.10.100 BICYCLE PARKING STANDARD	
LAND USE CATEGORY	MINIMUM REQUIRED BICYCLE PARKING SPACES
Residential Multi-family residential, general	1 space per unit



Multi-family residential, seniors or with physical disabilities	4, or 1 space per 5 units, whichever is greater
<b>Institutional</b> Schools – Elementary Schools - Jr. High/Middle School Schools - St. High College Transit Centers/Park & Ride Lots  Religious Institutions Hospitals Doctor, Dentist Offices Libraries, Museums, etc.	To be determined through design review To be determined through design review To be determined through design review To be determined through design review 5% of auto spaces (or 100% of demand, depending on accessibility to bicyclists) 1 space per 40 seat capacity 1 space per 5 beds 2, or 1 space per 1000 ft <sup>2</sup> , whichever is greater 2, or 1 space per 1000 ft <sup>2</sup> , whichever is greater
<b>Commercial</b> Retail Sales Auto-oriented Services Groceries/Supermarkets Offices Restaurants Drive-in Restaurants Shopping Centers Financial Institutions Theaters, Auditoriums, etc. Downtown Commercial Zone	0.33 space per 1000 ft <sup>2</sup> , whichever is greater 2, or 0.33 space per 1000 ft <sup>2</sup> , whichever is greater 0.33 space per 1000 ft <sup>2</sup> 2, or 1 space per 1000 ft <sup>2</sup> , whichever is greater 1 space per 1000 ft <sup>2</sup> 1 space per 1000 ft <sup>2</sup> 0.33 space per 1000 ft <sup>2</sup> 2, or 0.33 space per 1000 <sup>2</sup> , whichever is greater 1 space per 30 seats 4 spaces per block
<b>Industrial</b> Industrial Park Warehouse Manufacturing, etc.	2, or .1 space per 1000 ft <sup>2</sup> , whichever is greater 2, or .1 space per 1000 ft <sup>2</sup> , whichever is greater 2, or .15 space per 1000 ft <sup>2</sup> , whichever is greater

**NOTES:**

Each individual use needs to be evaluated for bicycle parking – e.g., a commercial accessory use in an industrial district may have different requirements than the industrial uses around it. Similarly, in mixed-use developments, the amount of each use and required bicycle parking needs" evaluation. Finally, within each use category one needs to consider the different user categories - residents, employees, customers, etc. - and parking requirements for each. (Ord. 1019 section I, 1999; Ord. 1043 section 3, 2000; Ord. 1076, 2001)

***Findings:** The proposed development meets or exceeds these Required Conditions. Bike parking racks have been provided near the main entry to each of the tenant spaces to accommodate a total of 40 bikes or 0.12/1000sf.*

**CHAPTER 16.32 M-1 LIGHT INDUSTRIAL ZONE**

**16.32.10 USES PERMITTED OUTRIGHT.**

Uses permitted outright in the M-1 zone shall be as follows:

- A. Manufacturing, fabricating, processing, compounding, assembling or packaging of products made from previously prepared materials such as cloth, plastic, paper, metal, wood (but not including sawmills or lumber mills), the operation of which will not result in
  - 1. The dissemination of dusts, gas, smoke, fumes, odors, atmospheric pollutants or noise which exceed Oregon Department of Environmental Quality standards
  - 2. Danger by reason of fire, explosion or other physical hazard;
  - 3. Unusual traffic hazards;

***Findings:*** *The proposed development meets or exceeds these Required Conditions. The proposed development is speculative and may include allowed uses as outlined in this section. Prohibited uses as noted will not be allowed in the industrial park.*

- B. Automobile body shop, or heavy repair shop;
- C. Contractor's equipment or storage yard;
- D. Dwelling for watchman or caretaker working on the property;
- E. Food processing plant;
- F. Fuel distribution, wholesale or retail;
- G. Ice or cold storage plant;
- H. Laundry or dry-cleaning plant;
- I. Lumber yard;
- J. Machinery, farm equipment or implement sales, service or rent;
- K. Motor or rail freight terminal;
- L. Railroad tracks and related facilities;
- M. Restaurant, when related and incidental to primary industrial uses of the area;
- N. Service station, when related and incidental to primary industrial uses of the area;
- O. Stone, marble, or granite cutting;
- P. Tire retreading or recapping;

Q. Transfer and storage company;

R. Utility storage or service yard;

S. Veterinarian's office or animal hospital;

T. Warehouse;

***Findings:*** *The proposed development meets or exceeds these Required Conditions. The proposed development is speculative and warehousing is likely to be the predominant use within the industrial park.*

U. Wholesale distribution, including warehousing and storage;

***Findings:*** *The proposed development meets or exceeds these Required Conditions. The proposed development is speculative and warehousing is likely to be the predominant use within the industrial park.*

V. Wireless or cellular communications facility/tower;

W. Other light industrial uses as determined by the Planning Commission;

X. Business or professional office, when related and incidental to primary industrial uses of the area;

***Findings:*** *The proposed development meets or exceeds these Required Conditions. The proposed development includes accommodations for an accessory office associated with the primary industrial use (warehouse storage and manufacturing) of the industrial park.*

Y. Public building or uses such as fire station, or park or playground.

Z. Attached WTS facilities (see 16.08.120).

AA. Detached WTS facilities (monopole or lattice tower), under 150 feet in height and at least 660 feet from the nearest land zoned or planned for residential use or Highway 99E (see 16.08.120).

BB. Detached WTS facilities (monopole), under 100 feet in height and less than 660 feet from the nearest land zoned or planned for residential use or Highway 99E (see 16.08.120).

CC. Detached WTS facilities (monopole), equal to or over 150 feet in height and at least 660 feet from the nearest land zoned or planned for residential use or Highway 99E (see 16.08.120).

DD. Minor public facility.

EE. Brewery: General manufacturing of products included in SIC 208: Beverages. (Ord. 890 section 31, 1993; Ord. 749 section 1(A), 1984, Ord. 740 section 10.3.31(A), 1984; Ord. 995 section 10 & 11, 1996; Ord. 981 section 30 & 31,

### **16.32.20 CONDITIONAL USES.**

Conditional uses in the M-1 zone shall be as follows:

- A. Commercial recreation uses;
- B. Motels, hotels and similar accommodations;
- C. Other heavy commercial or light industrial uses as determined by the Planning Commission;
- D. Waste and/or recycling transfer operations.
- E. Detached WTS facilities (monopole), equal to or over 100 feet in height and less than 660 feet from the nearest land zoned or planned for residential use or Highway 99E (see 16.08.120).
- F. Detached WTS facilities (lattice tower), equal to or over 150 feet in height and at least 660 feet from the nearest land zoned or planned for residential use or Highway 99E (see 16.08.120).
- G. Major public facility, except as modified by Section 16.32.010. (Ord. 960, section 2, 12/18/96; Ord. 890, section 32, 1993; Ord. 740 section 10.3.31(B), 1984; Ord. 981 section 32, 1997; Ord. 1237, 2007)

***Findings:** This criterion does not apply to this project. The proposed development does not propose any conditional uses as outlined in the City of Canby Development Code.*

### **16.32.30 DEVELOPMENT STANDARDS.**

The following subsections indicate the required development standards of the M-1 zone:

- A. Minimum lot area: five thousand square feet;

***Findings:** The proposed development meets or exceeds these Required Conditions. The proposed development area is greater than the minimum of five thousand square feet.*

- B. Minimum width and frontage: fifty feet;

***Findings:** The proposed development meets or exceeds these Required Conditions. The proposed development area has frontage greater than the minimum of fifty feet.*

- C. Minimum yard requirements:

- 1. Street yard: twenty feet where abutting Highway 99E and S. Ivy Street. Gas station canopies shall be exempted from the twenty foot setback requirements. Properties not

fronting on Highway 99E or S. Ivy Street shall maintain a 10 foot street yard setback. Sign setbacks along Highway 99-E and S. Ivy Street are to be measured from the face of the curb rather than the lot line. Where no curb exists, the setback shall be measured from the property line. Other than signs which are nonconforming structures and street banners which have been approved per the requirements of the Uniform Sign Code, no signs will be allowed to be located within, or to project over, a street right-of-way.

***Findings:*** *This criterion does not apply to this project. The proposed development is not located along HWY 99-E or S. Ivy Street.*

2. Interior yard: none, except ten feet where abutting a residential zone.

***Findings:*** *This criterion does not apply to this project. The proposed development is not adjacent to a residential zone.*

3. Rear yard: none, except ten feet where abutting a residential zone.

***Findings:*** *This criterion does not apply to this project. The proposed development is not adjacent to a residential zone.*

D. Maximum building height:

1. Freestanding signs: thirty feet;

***Findings:*** *This criterion does not apply to this project. The proposed development does not include the design of any free-standing signs.*

2. All other structures: forty-five feet.

***Findings:*** *The proposed development meets or exceeds these Required Conditions. The proposed building heights are below the maximum height of forty-five feet.*

E. Maximum lot coverage: no limit.

F. Other regulations:

1. Vision clearance distances shall be fifteen feet from any alley or driveway and thirty feet from any other street or railroad.

***Findings:*** *The proposed development meets or exceeds these Required Conditions. The proposed development will maintain vision clearances as outlined in this section.*

2. All setbacks to be measured from the foundation line of the building. Overhangs shall not exceed two feet.

**Findings:** *The proposed development meets or exceeds these Required Conditions. The building setback will be maintained as measured from the foundation line of the building.*

3. Prior to issuance of a building permit, wireless/cellular towers require written certification of approval/compliance from the Federal Communications Commission, Federal Aviation Administration and the Oregon Department of Transportation (Department of Aeronautics).

**Findings:** *This criterion does not apply to this project. The proposed development does not contain any proposed wireless/cellular towers.*

4. Outside storage areas abutting a residential zone shall be screened from view by a site-blocking fence, landscaping, or berm and shall be of such material and design as will not detract from adjacent residences. (Ord. 890 section 33, 1993; Ord. 830 section 11, 12, 1989; Ord. 740 section 10.3.31(C), 1984; Ord. 955 section 12, 1996; Ord. 981 section 51, 1997; Ord. 1237, 2007; Ord. 1514, 2019)

**Findings:** *This criterion does not apply to this project. The proposed development is not adjacent to a residential zone.*

## **CHAPTER 16.35 CANBY INDUSTRIAL OVERLAY (I-O) ZONE**

### **16.35.010 PURPOSE.**

The purpose of the Canby Industrial Area Overlay (I-O) zone is to implement the design guidelines and standards of the Canby Industrial Area Master Plan (Master Plan):

- A. Provide efficient circulation and access;
- B. Allow flexibility in siting development, including a range of industrial and commercial/industrial land uses;
- C. Provide visual continuity for streetscapes and developments;
- D. Encourage durable, high quality building materials.

The zone is intended to ensure high-quality industrial development with a mix of employment types and uses. (Ord. 1008 section 1 [part], 1998; Ord. 1057 section 2 [part], 2000)

### **16.35.20 APPLICABILITY.**

It is the policy of the City of Canby to apply the I-O zone to all lands within the Canby Pioneer Industrial Park Master Plan area and other areas determined by the City, as defined in the Industrial Area Master Plan. The Master Plan area generally includes the area bound by Highway 99E and 1st

Avenue to the north, Mulino Road to the east, SE 13th Avenue to the south, and the Molalla Forest Logging Road Trail to the west. The I-O zone has the following affect with regard to other chapters of this ordinance:

- A. Incorporates the Canby Industrial Area Master Plan into Title 16. The Master Plans design guidelines, standards, and plan maps are hereby incorporated by reference.
- B. Permits land uses which are permitted by the underlying zone districts (C-M, M-1, M-2), with some exceptions.
- C. Replaces selected development standards contained in the C-M, M-1, and M-2 zones, for continuity and quality of site design within the Master Plan area.
- D. Utilizes the City's processes for development review, including land divisions, conditional uses, and design reviews. Provides a design review matrix (i.e., replacing the table in Chapter 16.49) which is tailored to the Master Plan area.
- E. Provides additional conditional use standards to ensure development compatibility.
- F. Lists uses that are prohibited outright due to incompatibility with the goals for the area. (Ord. 1008 section 1 [part], 1998; Ord. 1057 section 2 [part], 2000)

***Findings:*** *The proposed development meets or exceeds these Required Conditions. The proposed development lies within the boundary of the Canby Pioneer Industrial Park and is Covered under the I/O Overlay district.*

### **16.35.25 PRE-APPLICATION REVIEW AND CONDITIONS OF APPROVAL**

- A. A pre-application meeting with utility and service providers is required prior to any land use application, building permit application, or business license application in the I-O zone, unless this requirement is waived by the City Planner. The City Planner shall provide application forms for this purpose indicating all required information. The pre-application meeting shall allow utility and service providers to make a detailed assessment of the proposed use prior to forming a recommendation on approval. In addition, this meeting will allow the City to evaluate whether a Conditional Use Permit will be required.

***Findings:*** *The Pre-Application conference was held on July 9<sup>th</sup>, 2019*

- B. At the pre-application meeting, the City shall determine the need for a Hazardous Materials Management Plan. If required by the City, the applicant shall prepare a plan meeting the relevant sections of the Oregon Fire Code as determined by the City. The Plan shall allow utility and service providers to review the health and safety impacts of any proposed use and ensure an adequate plan will be in place to address those impacts prior to forming a recommendation on approval.



***Findings:*** *At the Pre-Application Conference, It was determined that this development would not require a Hazardous Material Management Plan.*

- C. The Planning Commission or City Council may impose conditions to protect public health and safety on any discretionary land use application. (Ord. 1057 section 2 [part], 2000; Ord. 1237, 2007)

### **16.35.030 USES PERMITTED OUTRIGHT.**

Unless limited by sections 16.35.040 or 16.35.045, uses permitted outright in the C-M zone, M-1 zone, and M-2 zone are permitted outright in the I-O zone, subject to the respective zone district boundaries. (Ord. 1008 section 1 [part], 1998; Ord. 1057 section 2 [part], 2000)

***Findings:*** *The proposed development meets or exceeds these Required Conditions. The proposed development is speculative and all uses will comply with the outright allowed uses allowed in the M-1 zone.*

### **16.35.40 CONDITIONAL USES.**

Unless limited by subsection A below or section 16.35.045, conditional uses permitted in the C-M zone, M-1 zone, and M-2 zone are permitted as conditional uses in the I-O zone, subject to the respective zone district boundaries.

- A. Any proposed site development, change in use, land division, or other action that results in any of the following requires conditional use approval in the I-O zone:
1. Less than 3 employees per developed acre. For the purposes of this section only, "developed" means all areas used for buildings, landscaping, vehicle maneuvering and parking areas, outdoor storage, and other areas occupied by the use. For the purposes of this section only, employees means full-time equivalents unless the City specifically allows other interpretations;

***Findings:*** *The proposed speculative development meets or exceeds these Required Conditions. The development area is approx. 21 acres which would require a total of 63 employees.*

2. More than 60 acres total in I-O zoning that is occupied by a single use or business. For the purposes of this section, businesses classified in the same NAICS industry group (four-digit code) are considered to be in the same use. This section is intended to apply cumulatively to all properties in the zone;

***Findings:*** *The proposed development meets or exceeds these Required Conditions. The proposed speculative development does not contain a development area greater than 60 acres.*

3. Utilization of any public service or utility to such an extent that the utility would not be able to supply all other uses projected in its current long-range plans;

**Findings:** *The proposed development meets or exceeds these Required Conditions. The proposed speculative development will utilize City utilities but will not adversely impact the supply for future developments.*

4. Uses requiring an H occupancy under the Oregon Structural Specialty Code;

**Findings:** *The proposed development meets or exceeds these Required Conditions. As the proposed development is speculative, it is understood that any H occupancy uses considered for occupying space within the industrial park will require supplemental conditional use approval.*

5. In any C-M zoning overlain by I-O zoning, any retail or commercial use with a building footprint exceeding 50,000 square feet;

**Findings:** *The proposed development meets or exceeds these Required Conditions. The proposed development does not lie within a C-M zone.*

6. In any M-1 or M-2 zoning overlain by I-O zoning, any retail or commercial use not related to or supportive of the primary industrial use of the park; or

**Findings:** *The proposed development meets or exceeds these Required Conditions. As the proposed development is speculative, it is understood that any retail or commercial use not related to the primary industrial use of the park will require supplemental conditional use approval.*

7. In any M-1 or M-2 zoning overlain by I-O zoning, retail areas occupying more than 15% of the building footprint.

**Findings:** *The proposed development meets or exceeds these Required Conditions. As the proposed development is speculative, it is understood that any proposed use with retail areas occupying more than 15% of the building footprint will require supplemental conditional use approval.*

- B. To approve a conditional use in the I-O zone, the Planning Commission shall find that each of the following additional criteria are either met, or can be met by observance of conditions, unless it is not applicable:
  1. The proposed use is compatible with the industrial nature of the park and will have minimal negative impact on the development and use of surrounding properties;
  2. The proposed use does not pose a threat to public health or safety; and
  3. The proposed use is beneficial to the overall economic diversity and vitality of the City.

These criteria are in addition to those provided in Section 16.50.010. In all other aspects, the conditional use process shall be as specified in Chapter 16.50. (Ord 1008 section 1 [part], 1998, Ord. 1057 section 2 [part], 2000; Ord. 1237, 2007; Ord. 1514, 2019).

***Findings:** This criterion does not apply to this project. The proposed development does not include the application for any Conditional Uses.*

### **16.35.45 PROHIBITED USES.**

The following uses are prohibited in the I-O zone:

- A. Slaughter house;
- B. Rendering, reduction, or distillation of, or manufacturing from, animals, fish and their by-products;
- C. Auto, truck or motorcycle race track;
- D. Auto, truck, or motorcycle wrecking or salvage yard;
- E. Scrap metal storage and sales;
- F. Reclamation or manufacturing of steel barrels or drums;
- G. Dump or landfill, including rubbish, slag, organic materials, offal, or garbage in general;
- H. Livestock feeding pen, other than those associated with existing agricultural uses;
- I. Fireworks manufacturing or the manufacturing of ammunition or explosives;
- J. Nuclear power plant or similar use;
- K. Curing and storage of hides;
- L. Incinerator, smelter, blast furnace, or coke oven;
- M. Manufacture of oils, gasoline, or products made directly from petroleum, other oils, or tar products;
- N. Fertilizer production;
- O. Creosote production;
- P. Insecticide production;
- Q. Tire manufacturing;

- R. Saw, shingle, or lumber mill; and
- S. In any M-1 or M-2 zoning overlain by I-O zoning, commercial or retail uses over 50,000 square feet are prohibited.

This list should not be used to imply that any other use is permitted. (Ord. 1057 section 2 [part], 2000)

***Findings:*** *The proposed development meets or exceeds these Required Conditions. The proposed development does not contain any of the uses outlined in this section.*

### **16.35.50 DEVELOPMENT STANDARDS.**

The following subsections indicate the required development standards of the I-O zone. These standards replace the standards of the C-M zone, M-1 zone, and M-2 zone, as follows:

- A. Minimum lot area: none.

***Findings:*** *The proposed development meets or exceeds these Required Conditions. No Restriction.*

- B. Minimum lot width and frontage: none.

***Findings:*** *The proposed development meets or exceeds these Required Conditions. No Restriction.*

- C. Minimum yard requirements (measured from building foundation to right-of-way line):

- 1. Street yards(s): 20 feet for buildings up to 25 feet in height; 35 feet for buildings between 25 feet and 45 feet in height. Parking and internal drives (except curb cuts and entrance drives) are prohibited within the required 20 foot street yard.

***Findings:*** *The proposed development meets or exceeds these Required Conditions. The proposed development contains a building with a height between 25 feet and 45 feet and as designed, minimum setbacks of more than 80 feet from the right-of-way. The Parking setback is equal to or greater than the minimum of 20 feet.*

- 2. Interior yard: 10 feet, except 20 feet where abutting a residential zone. Common-wall lot lines (attached buildings), and development which provide shared parking and circulation with abutting developments, are exempt from interior yard standards.

***Findings:*** *The proposed development meets or exceeds these Required Conditions. The side yard setbacks exceed the minimum 10-foot requirement.*

3. Rear yard: 10 feet, except 20 feet where abutting a residential zone. Common-wall lot lines (attached buildings), and development which provide shared parking and circulation with abutting developments, are exempt from interior yard standards.

**Findings:** *The proposed development meets or exceeds these Required Conditions. The rear yard setbacks exceed the minimum 10-foot requirement.*

- D. Maximum building height: 45 feet.

**Findings:** *The proposed development meets or exceeds these Required Conditions. The proposed development contains 3 buildings with wall heights below the maximum height limitation of 45 feet.*

- E. Maximum lot coverage: 60 percent in the C-M zone; none in the M-1 and M-2 zones.

**Findings:** *The proposed development meets or exceeds these Required Conditions. There is No Restriction to lot coverage as the proposed development lies within the M-1 Zone.*

- F. Street access (curb cuts) spacing shall be a minimum of 200 feet on designated parkway and collector streets.

**Findings:** *The proposed development meets or exceeds these Required Conditions. The driveways at SE 1<sup>st</sup> Ave., which is designated as a collector are spaced 480ft apart with the western drive located 325ft from the intersection of SE Hazel Del and the eastern drive located 420ft from S Walnut St. The driveways at S Walnut St., which is designated as a local street are spaced 443ft apart with the north drive located 400ft from the SE 1<sup>st</sup> Ave intersection and the south drive located 76ft from the neighbors drive to the south.*

- G. Street right-of-way improvements shall be made in accordance with the Canby Transportation System Plan (TSP).

**Findings:** *The proposed development meets or exceeds these Required Conditions. The proposed development is designed to include half street improvements to SE 1<sup>st</sup> Ave. and S Walnut St. as directed by the City during the Pre-Application Conference.*

- H. Building orientation standards. The following standards are intended to ensure direct, clear, and convenient pedestrian access:
  1. Development in the M-1 zone and M-2 zone shall provide at least one public entrance facing the street. A direct pedestrian connection shall be provided between the primary building entrance and public sidewalk.

**Findings:** *The proposed development meets or exceeds these Required Conditions. The proposed speculative development is designed to have the main entrances of all buildings facing the streets with multiple pedestrian connections to the street sidewalks and interior*

*circulation sidewalks. Pedestrian access is provided via a striped pedestrian path across the drive aisle with onsite sidewalks connected to the City sidewalk at or near the main entrances.*

2. Developments within the C-M zone shall provide continuous, straight-line pedestrian connections between the street(s), buildings, and parking areas.

***Findings:*** *This criterion does not apply to this project. The proposed development does not lie within the C-M zone.*

- I. Right-of-way plantings: Street trees and ground cover plantings shall be installed with development, as approved by the City. Shrubs are prohibited within the public right-of-way.

***Findings:*** *The proposed development meets or exceeds these Required Conditions. The proposed development is designed to include street trees and ground cover within the ROW plantings which shall be approved by the City.*

- J. Metal building exteriors are prohibited, except that the Planning Commission may approve architectural metal elements that accent and enhance the aesthetics of building entrances and office areas

***Findings:*** *The proposed development meets or exceeds these Required Conditions. The proposed development is designed to be constructed of concrete tilt-up materials. The building elevations have been designed to define the office entrances with a combination of panel articulation, storefront glazing, cornice elements, recessed entries and a complimentary paint scheme which is further enhanced by vertical and horizontal reveals extending around the perimeter of the building. Refer to Architectural elevations included in this submittal for reference.*

- K. Lighting shall be required for all streets, sidewalks, and pedestrian ways. Applications for land division approval and site plan review shall include photometric plans.

***Findings:*** *The proposed development meets or exceeds these Required Conditions. The proposed development includes the addition of street lighting, building lighting and site pole lighting to effectively illuminate the pedestrian pathways, parking, drive aisles and loading areas. A photometrics plan has been included with the site plan review submittal.*

- L. Shared access: The City may require the provision of shared access drives through the land division review process. Shared access drives are intended to maintain adequate driveway spacing and circulation along the designated Parkway and Collector streets.

***Findings:*** *Joint/shared access is proposed for the driveway at Walnut St. which is centered between buildings A&B and for the driveway at SE 1<sup>st</sup> Ave between buildings A&C. Although the developer has had discussions with the neighbors to the south and to the west, they have not agreed to locating shared access drives on the common property lines.*

- M. All landscaped areas shall be irrigated unless drought tolerant plants are installed and watered until well established and replaced in event of failure.

***Findings:*** *The proposed development meets or exceeds these Required Conditions. The proposed development includes landscape irrigation for all landscaped areas.*

- N. Other regulations: The C-M zone, M-1 zone, and M-2 zone provide other applicable regulations related to vision clearance, Highway 99E sidewalk width, setback measurement, outside storage, and wireless/cellular tower certification.

***Findings:*** *The proposed development meets or exceeds these Required Conditions. The proposed development will meet the requirements of other applicable regulations in regards to vision clearance and outside storage.*

- O. Open storage or “laydown yards” shall be screened by a six foot site-obscuring fence or hedge-type vegetation that would become a solid site obscuring barrier within three years of planting. (Ord. 1008 section 1 [part], 1998; Ord. 1237, 2007; Ord. 1299, 2008; Ord. 1514, 2019)

***Findings:*** *The proposed development meets or exceeds these Required Conditions. As the development is speculative, no laydown areas are proposed at this time however it is understood that such areas will be screened in accordance with this section of code.*

### **16.35.60 DESIGN GUIDELINES.**

The Industrial Area Master Plan provides design guidelines for reviewing development applications. The guidelines, which are incorporated into Table 16.35.040, encourage:

- A. Flexibility to align local streets based on parcelization and development requirements;
- B. Tree retention, planting of large (3-inch) caliper trees, and use of lawn/ground cover planting in front yard setbacks;
- C. Placement of buildings at or near the setback line;
- D. Placement of parking areas to the side or rear of buildings;
- E. Placement of smaller commercial buildings at or near the street;
- F. Building entries visible from the street with direct pedestrian connections;
- G. Use of quality building materials;
- H. Architectural detail to break up and articulate large surfaces and volumes, and to accentuate building entries; and



- I. Open space retention and trail connections, as designated by the Master Plan. (Ord. 1008, section 1 [part], 1998)

**16.35.70 I-O DESIGN REVIEW MATRIX.**

The City uses the following matrix to evaluate compliance with the I-O design guidelines. The matrix substitutes for the general design review matrix provided in Chapter 16.49. Design review applications must comply with all other applicable provisions of Chapter 16.49, and achieve scores equal to or greater than the minimum acceptable scores in the matrix. (See Master Plan for illustrations.)

- A. Exception: The City may reduce the minimum acceptable score(s) upon finding that certain provisions do not apply to a proposed development.

Industrial Overlay Design Review Matrix  
**Table 16.35.040**

CRITERIA	Possible Scores
<b><u>Parking</u></b>	
Parking areas located to the side or rear of buildings as viewed from public right-of-way: <50% of parking spaces=0; 50%-75%=1; 75%-100%=2.	<b>0</b> <b>1</b> <b>2</b>
Increase minimum interior parking lot landscape over the base 15%: 15%-18%=0; 18%-22%=1; >22%=2.	<b>0</b> <b>1</b> <b>2</b>
Increase the base number of trees required by 16.49.120 (all landscape islands must contain 1 tree, 1 tree for every 40' along the required setback): 100%-105% of base requirement=0; 105%-110% of base requirement=1;>110%=2; (# of trees proposed/# of trees required x100=% of base requirement)	<b>0</b> <b>1</b> <b>2</b>
Number of parking spaces provided: (% of required minimum): >110%=0; 110%-105%=1; 105%-100%=2. See Table 16.10.050 for required parking. (# of spaces proposed/# of spaces required x100=% of required minimum)	<b>0</b> <b>1</b> <b>2</b>
<b>Minimum Acceptable Score</b> <span style="float: right;"><b>4 points</b></span>	<b>Total 2</b>
<b><u>Transportation/Circulation</u></b>	
Design private, on-site pedestrian pathways: 6' painted ways=0; 6' brick/paver ways=1; 6' brick/paver & raised <b>concrete</b> ways=2	<b>0</b> <b>1</b> <b>2</b>
Number of pedestrian connections between the street sidewalk and internal circulation system: One connection = 0 Two or more connections = 1	<b>0</b> <b>1</b> <b>2</b>
<b>Minimum Acceptable Score (some provisions may not apply) 2points</b>	<b>Total 3</b>
<b><u>Landscaping</u></b>	
Trees installed at 3 inch caliper: <25% of trees=0; 25%-50%=1; 50%-100%=2.	<b>0</b> <b>1</b> <b>2</b>

Usable outdoor amenity provided with development (e.g., water features, plazas, seating areas, and similar features): no=0; yes=1; yes and for public use =2.	0	1	2
Amount of grass (less grass is better) (% of total landscaped area)>50%=0; 25%-50%=1; <25%=2	0	1	2
<b>Minimum Acceptable Score</b>	<b>3 points</b>		<b>Total 4</b>

<b><u>Building Appearance and Orientation</u></b>			
Building orientation at or near the street: parking or drive separates building from street=0; at least 20% of elevation within 5 feet of minimum setback=1; at least 20% of elevation is at minimum setback=2.	0	1	2
Building entrances visible from the street: no=0; yes=1.	0	1	
Buildings use quality materials: concrete, wood, or wood siding=0; concrete masonry, stucco, or similar material=1; brick or stone=2.	0	1	2
Articulation and/or detailing to break up large building surfaces and accentuate the building entrance(s): no=0; yes=2.	0		2
<b>Minimum Acceptable Score</b>	<b>4 points</b>		<b>Total 4</b>

**CHAPTER 16.42 SIGNS**

**Findings:** *This criterion does not apply to this project. Although the site plans include accommodations for monument signs, we are not requesting approval of these signs with the development application.*

**CHAPTER 16.43 OUTDOOR LIGHTING STANDARDS**

**16.43.40 LIGHTING ZONES.**

- A. Zoning districts designated for residential uses (R-1, R-1.5 and R-2) are designated Lighting Zone One (LZ 1). All other zoning districts are designated Lighting Zone Two (LZ 2).

**Findings:** *The proposed development will follow the Zone Two (LZ 2) requirements.*

- B. The designated Lighting Zone of a parcel or project shall determine the limitations for lighting as specified in this ordinance.

**Findings:** *The proposed development will follow the Zone Two (LZ 2) requirements.*

**TABLE 16.43.040 LIGHTING ZONE DESCRIPTIONS**

Zone	Ambient Illumination	Representative Locations
LZ 1	Low	Rural areas, low-density urban neighborhoods and districts, residential historic districts. This zone is intended to be the default for residential areas.
LZ 2	Medium	High-density urban neighborhoods, shopping and commercial districts, industrial parks and districts. This zone is intended to be the default condition for commercial and industrial districts in urban areas.

**16.43.60 PROHIBITED LIGHT AND LIGHTING.**

- A. All outdoor light sources, except streetlights, shall be shielded or installed so that there is no direct line of sight between the light source or its reflection at a point 3 feet or higher above the ground at the property line of the source. Light that does not meet this requirement constitutes light trespass. Streetlights shall be fully shielded. However, the applicant is permitted to have some unshielded lighting if lumens are within the limits of Table 16.43.070 below.

***Findings:** The proposed development meets or exceeds these Required Conditions. The proposed development includes a lighting design that is sensitive to the light trespass requirements outlined in this section. Street lighting design is present and also meets the requirements of this section.*

- B. The following lighting systems are prohibited from being installed or used except by special use permit:.

- 1. Aerial Lasers.

***Findings:** The proposed development meets or exceeds these Required Conditions. The proposed development does not include aerial lasers.*

- 2. "Searchlight" style lights.

***Findings:** The proposed development meets or exceeds these Required Conditions. The proposed development does not include "searchlight" style lights.*

- 3. Other very intense lighting, defined as having a light source exceeding 5200 lumens.

**Findings:** *The proposed development meets or exceeds these Required Conditions. The proposed development does not include lighting having a light source that exceeds 5200 lumens.*

### **16.43.70 LUMINAIRE LAMP LUMENS, SHIELDING, AND INSTALLATION REQUIREMENTS.**

- A. All outdoor lighting shall comply with the limits to lamp wattage and the shielding requirements in Table 16.43.070 per the applicable Lighting Zone. These limits are the upper limits. Good lighting design will usually result in lower limits.

**Findings:** *The proposed development meets or exceeds these Required Conditions. The proposed development will include lighting fixtures that comply with the requirements of this section. 'Good lighting' design applications will be utilized where possible.*

- B. The city may accept a photometric test report, lighting plan, demonstration or sample, or other satisfactory confirmation that the luminaire meets the requirements of the shielding classification.

**Findings:** *The proposed development meets or exceeds these Required Conditions. The proposed development will include a photometrics plan during the site review process that includes the lighting fixture specification showing that the luminaires used meet the requirements of this section.*

- C. Such shielded fixtures must be constructed and installed in such a manner that all light emitted by the fixture complies with the specification given. This includes all the light emitted by the fixture, either directly from the lamp or by a diffusing element, or indirectly by reflection or refraction from any part of the fixture. Any structural part of the fixture providing this shielding must be permanently affixed.

**Findings:** *The proposed development meets or exceeds these Required Conditions. The proposed development will include a photometrics plan during the site review process that includes the lighting fixture specification showing that the luminaires used meet the requirements of this section.*

- D. All canopy lighting must be fully shielded. However, indirect upward light is permitted under an opaque canopy provided that no lamp or vertical element of a lens or diffuser is visible from beyond the canopy and such that no direct upward light is emitted beyond the opaque canopy.

**Findings:** *The proposed development meets or exceeds these Required Conditions. The proposed development will include a photometrics plan during the site review process that includes the lighting fixture specification showing that the luminaires used meet the requirements of this section.*

- E. Landscape features shall be used to block vehicle headlight trespass while vehicles are at an external point of service (i.e. drive-thru aisle).

**Findings:** *The proposed development meets or exceeds these Required Conditions. The proposed development includes a landscape design that screens the parking spaces with regards to light trespass from vehicle head lights. Drive-thru aisles are not included in this development.*

- F. All facade lighting must be restricted to the facade surface. The margins of the facade shall not be illuminated. Light trespass is prohibited.

**Findings:** *The proposed development meets or exceeds these Required Conditions. The proposed development does not propose façade lighting at this time. Building wall pack lights and down lights at the canopy are the two types of on-site lighting that is designed. Street lighting is also included with this development.*

**TABLE 16.43.070 – LUMINAIRE MAXIMUM LUMENS AND REQUIRED SHIELDING**

Lighting Zone	Fully Shielded	Shielded	Partly Shielded	Unshielded (Shielding is highly encouraged. Light trespass is prohibited.)
LZ 1	2600 lumens or less	800 lumens or less	None Permitted	Low voltage landscape lighting and temporary holiday lighting.
LZ 2	7800 lumens or less	1600 lumens or less	800 lumens or less	Landscape and facade lighting 1600 lumens or less; ornamental lights of 800 lumens or less.

**16.43.80 HEIGHT LIMITS.**

Pole and surface-mounted luminaires under this section must conform with Section 16.43.070.

- A. Lighting mounted onto poles or any structures intended primarily for mounting of lighting shall not exceed a mounting height of 40% of the horizontal distance of the light pole from the property line, nor a maximum height according to Table 16.43.080, whichever is lower. The following exceptions apply:
  1. Lighting for residential sports courts and pools shall not exceed 15 feet above court or pool deck surface.
  2. Lights specifically for driveways, and then only at the intersection of the road providing access to the site, may be mounted at any distance relative to the property line, but may not exceed the mounting height listed in Table 16.43.080.

3. Mounting heights greater than 40% of the horizontal distance to the property line but no greater than permitted by Table 16.43.080 may be used provided that the luminaire is side-shielded toward the property line.
4. Landscape lighting installed in a tree. See the Definitions section.
5. Street and bicycle path lights.

**Findings:** *The proposed development meets or exceeds these Required Conditions. Site Lighting is supplied solely for the illumination of pedestrian pathways, auto parking and truck loading/maneuvering and will meet the requirements of this section. The luminaires on the pole lights in proximity to the south and west property lines will include side shields to mitigate light trespass.*

- B. Lighting mounted onto buildings or other structures shall not exceed a mounting height greater than 4 feet higher than the tallest part of the building or structure at the place where the lighting is installed, nor higher than 40% of the horizontal distance of the light from the property line, whichever is less. The following exceptions apply:
1. Lighting attached to single family residences shall not exceed the height of the eave. Lighting for driveways shall conform to Table 16.43.080.
  2. Lighting for facades may be mounted at any height equal to or less than the total height of the structure being illuminated regardless of horizontal distance to property line.
  3. For buildings less than 40 feet to the property line, including canopies or overhangs onto the sidewalk or public right of way, luminaires may be mounted to the vertical facade or the underside of canopies at 16 feet or less.
  4. The top exterior deck of parking garages should be treated as normal pole mounted lighting rather than as lights mounted to buildings. The lights on the outside edges of such a deck must be side shielded to the property line.

**Findings:** *The proposed development meets or exceeds these Required Conditions. The proposed development has design wall mounted light fixtures to be below the top of the wall of the building.*

**TABLE 16.43.080 – MAXIMUM LIGHTING MOUNTING HEIGHT IN FEET**

Lighting Zone	Lighting for Driveways, Parking and Transit	Lighting for Walkways, Plazas and other Pedestrian Areas	All Other Lighting
LZ 1	35.0	18.0	8.0
LZ 2	37.5	18.0	15.0

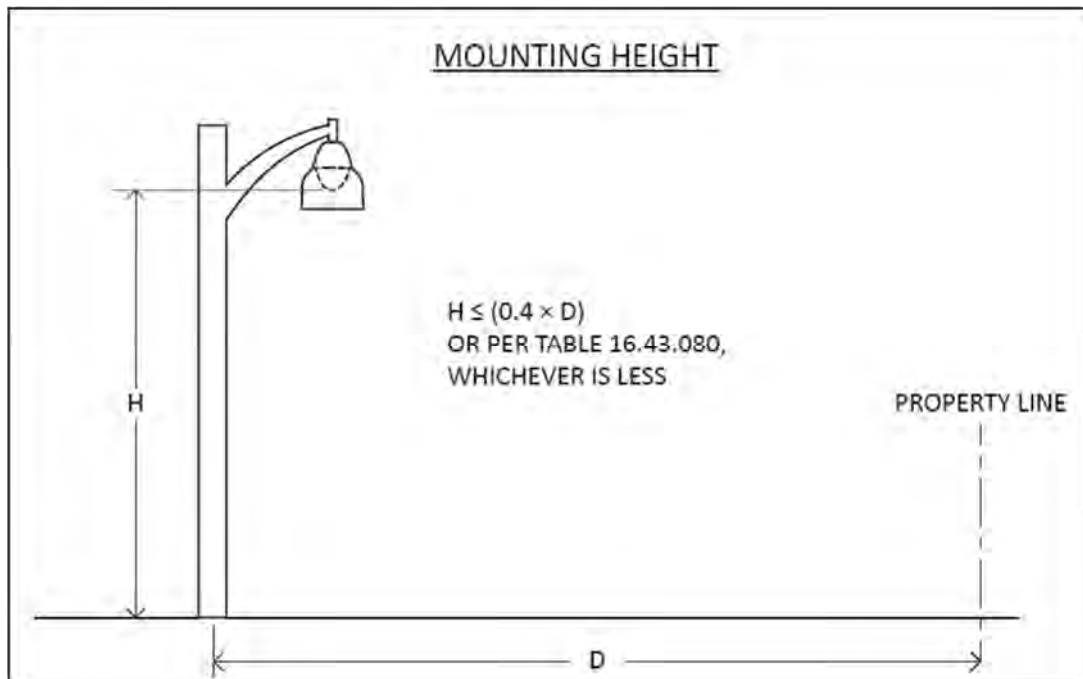

**FIGURE 16.43.2: MOUNTING HEIGHT**

**16.43.090 LIGHTING CONTROLS**

The city strongly recommends the use of timers and/or motion detectors on outdoor lighting, and that motion detectors be set to minimize unnecessary activation. For example, motion detectors for entryway or driveway lights should not activate for off-site pedestrians or cars.

**16.43.100 EXCEPTIONS TO STANDARDS.**

- A. Exceptions to the lighting standards in this section may be approved by the Planning Director. Lighting systems not complying with the technical requirements of this ordinance but consistent with the intent of the ordinance may be approved for the following:
  - 1. Sport fields.
  - 2. Construction lighting.
  - 3. Industrial lighting for hazardous areas where the heat of the lighting fixture may cause a dangerous situation.
  - 4. National and State Flag lighting with spotlights greater than 450 lumens.
- B. To obtain such approval of an exception, applicants shall demonstrate that the proposed lighting installation:



1. Has received every reasonable effort to mitigate obtrusive light and artificial sky glow, supported by a signed statement from a registered engineer or by a lighting certified professional describing the mitigation measures.
2. The Planning Director shall review each such application. Approval may be granted if, upon review, the Planning Director believes that the proposed lighting will not create unwarranted glare, sky glow, or light trespass.

***Findings:*** *This criterion does not apply to this project. The proposed development does not include exceptions to the standard requirements.*

### **16.43.110 LIGHTING PLAN REQUIRED**

A lighting plan shall be submitted with the development or building permit application and shall include:

- A. A site plan showing the location of all buildings and building heights, parking, and pedestrian areas.
- B. The location and height (above grade) of all proposed and existing luminaires on the subject property.
- C. Luminaire details including type and lumens of each lamp, shielding and cutoff information, and a copy of the manufacturer's specification sheet for each luminaire.
- D. Control descriptions including type of control (time, motion sensor, etc.), the luminaire to be controlled by each control type, and the control schedule when applicable.
- E. Any additional information necessary to demonstrate compliance with the standards in this section. (Ord.1338, 2010)

***Findings:*** *The proposed development meets or exceeds these Required Conditions. The proposed development will include a photometrics plan during the site review process that includes the lighting fixture specification showing that the luminaires used meet the requirements of this section.*

## **CHAPTER 16.46 ACCESS LIMITATIONS**

### **16.46.10 NUMBER OF UNITS IN RESIDENTIAL DEVELOPMENT.**

A major factor in determining the appropriate density of residential development, particularly in higher density areas, is vehicular access. In order to assure that sufficient access is provided for emergency response as well as the convenience of residents, the following special limitations shall be placed on the allowable number of units in a residential development:

- A. Single-family residential access, public and private roads:

1. Roads shall be a minimum of 28 feet in width with parking restricted to one side only, or a minimum of 34 feet in width with no parking restriction.
2. The number of units permitted are as follows:

One access:	30 units
Two accesses:	132 units
Three accesses:	207 units

For more than three accesses, use the following formula: # of units permitted =  $(60 \times (1 + (.05 \times \# \text{ of access points}))) \times (\# \text{ of access points})$

- B. Single ownership developments (condominiums, townhouses, manufactured homes, multi-family developments, etc.).

1. Two lane access roads/drives shall be a minimum width of 20 feet with no parking permitted, or 28 feet with parking restricted to one side only, or 34 feet with no parking restrictions. Three lane access roads/drives shall be a minimum width of 32 feet with no parking permitted, or 40 feet with parking restricted to one side.

2. The number of units permitted are as follows:

Two lane access road/drive	Three lane access road/drive
One access: 30 units	One access: 30 units
Two accesses: 165 units	Two accesses: 220 units
Three accesses: 258 units	Three accesses: 345 units

For more than three accesses on a two lane access road/drive, use the following formula:  
 # of units permitted =  $(75 \times (1 + (.05 \times \# \text{ of access points}))) \times (\# \text{ of access points})$  (round down to the nearest whole number)

For more than three accesses on a three lane access road/drive, use the following formula:  
 # of units permitted =  $(100 \times (1 + (.05 \times \# \text{ of access points}))) \times (\# \text{ of access points})$

- C. The Planning Commission may allow increases beyond the maximum number of units listed in subsections A and B. Such increases shall be based upon findings that no unwarranted problems for the public street system or emergency service provision will result.
- D. All turnaround systems shall meet or exceed the requirements of the parking provisions of Chapter 16.10.

- E. All on-site private roads and drives shall be designed and constructed to provide safe intersections and travel surfaces which will not result in hazards for motorists, bicyclists or pedestrians.
- F. N. Maple Street, north of NE 23rd Avenue, and S. Elm Street, south of SW 13th Avenue, shall be exempt from the residential unit restrictions for single access roads, provided that legally binding alternative emergency vehicle access is available. Road width requirements for these roads shall remain in effect.
- G. Public roads accessing any development shall be a minimum of two travel lanes (twenty-four (24) feet of paved width) to the nearest improved collector or arterial street, provided that any required improvement to provide additional pavement width to access a development meets both of the following conditions:
  - 1. An essential nexus is proven, whereby the required improvement is directly related to the proposed development; and
  - 2. Rough proportionality is proven, whereby the cost of the required improvement is roughly proportional to the impact that the development will have on the infrastructure. Specific findings are required for each of the conditions listed above. If either of the two conditions are not met, the infrastructure is considered to be inadequate, and conditioning approval of a development on the widening of the access to the development is considered to be inappropriate. (Ord. 955 section 22, 1996; Ord. 1019 section 21, 1999; Ord. 1237, 2007; Ord. 1514, 2019)

**Findings:** *This criterion does not apply to this project. The proposed development does not include and residential development.*

#### **16.46.20 INGRESS AND EGRESS.**

Ingress and egress to any lot or parcel, the creation of which has been approved by the Planning Commission, shall be taken along that portion fronting on a public street unless otherwise approved by the Planning Commission.

##### **A. Vision Clearance:**

Vision clearance distance shall be ten feet from a street to an alley or a street to a driveway and thirty feet from a street to any other street.

- B. Where an existing alley is 20 feet or less in width, the setback abutting the alley shall increase to provide a minimum of 24 feet for maneuvering and backing movements from, garages, carports, or parking areas. (Ord. 740 section 10.3.62, 1984; Ord. 1514, 2019)

**Findings:** *The proposed development meets or exceeds these Required Conditions. Access driveways serving the development occur at the property street frontages.*

**16.46.30 ACCESS CONNECTION.**

Spacing of accesses on City streets. The number and spacing of accesses on City streets shall be as specified in Table 16.46.030. Proposed developments or land use actions that do not comply with these standards will be required to obtain an access spacing exception and address the joint and cross access requirements of this Chapter. (Ord. 1043 section 3, 2000; Ord. 1076, 2001; Ord. 1237, 2007)

**TABLE 16.46.30 ACCESS MANAGEMENT GUIDELINES FOR CITY STREETS\***

Street Facility	Maximum spacing** of roadways	Minimum spacing** of roadways	Minimum spacing** of roadway to driveway***	Minimum Spacing** driveway to driveway***
Arterial	1,000 feet	660 feet	330 feet	330 feet or combine
Collector	600 feet	250 feet	100 feet	100 feet or combine
Neighborhood/Local	600 feet	150 feet	50 feet****	10 feet

\* Exceptions may be made in the downtown commercial district, if approved by the City Engineering or Public Works Department, where alleys and historic street grids do not conform to access spacing standards.

\*\* Measured centerline on both sides of the street

\*\*\* Private access to arterial roadways shall only be granted through a requested variance of access spacing policies when access to a lower classification facility is not feasible (which shall include an access management plan evaluation).

\*\*\*\* Not applicable for single-family residential driveways; refer to section 16.10.070(B)(10) for single-family residential access standards

Note: Spacing shall be measured between access points on both sides of the street. (Ord. 1340, 2011)

***Findings:** The proposed development meets or exceeds these Required Conditions. The driveways at SE 1<sup>st</sup> Ave., which is designated as a collector are spaced 480ft apart with the western drive located 325ft from the intersection of SE Hazel Del and the eastern drive located 420ft from S Walnut St. The driveways at S Walnut St., which is designated as a local street are spaced 443ft apart with the north drive located 400ft from the SE 1<sup>st</sup> Ave intersection and the south drive located 78ft from the neighbors drive to the south.*

**16.46.035 RESTRICTED ACCESS.**

The City may allow an access to a City street that does not meet the spacing requirements of Table 16.46.030 if the proposed access is restricted (prevents certain turning movements). The City may require an applicant to provide an engineered traffic study, access management plan, or other information as needed to demonstrate that the roadway will operate within the acceptable standards with the restricted access in place. (Ord. 1237, 2007). Access to OR 99E shall be regulated by ODOT through OAR 734.51. (Ord. 1340, 2011)

#### **16.46.40 JOINT AND CROSS ACCESS.**

Any developments requiring site plan review that do not meet access spacing requirements are subject to these requirements. In these cases, the following information shall be shown on the site plan.

- A. Adjacent commercial or office properties classified as major traffic generators (e.g. shopping plazas, office parks), shall provide a cross access drive and pedestrian access to allow circulation between sites.
- B. A system of joint use driveways and cross access easements shall be established wherever feasible and shall incorporate the following:
  1. A continuous service drive or cross access corridor extending the entire length of each block served to provide for driveway separation consistent with the access management classification system and standards;
  2. A design speed of 10 mph and a minimum width of 20 feet to accommodate two-way travel aisles designated to accommodate automobiles, service vehicles, and loading vehicles;
  3. Stub-outs and other design features to make it visually obvious that the abutting properties may be tied in to provide cross-access via a service drive;
  4. A unified access and circulation system plan for coordinated or shared parking areas is encouraged.
- C. Shared parking areas may be permitted a reduction in required parking spaces if peak demands do not occur at the same time periods.
- D. Pursuant to this section, property owners shall:
  1. Record an easement with the deed allowing cross access to and from other properties served by the joint use driveways and cross access or service drive;
  2. Record an easement with the deed that remaining access rights along the roadway will be dedicated to the city and pre-existing driveways will be closed and eliminated after construction of the joint-use driveway;
  3. Record a joint maintenance agreement with the deed defining maintenance responsibilities of property owners.
- E. The City may reduce required separation distance of access points where they prove impractical, provided all of the following requirements are met:

1. Joint access driveways and cross access easements are provided in accordance with this section.
  2. The site plan incorporates a unified access and circulation system in accordance with this section.
  3. The property owner enters into a written agreement with the city, recorded with the deed, that pre-existing connections on the site will be closed and eliminated after construction of each side of the joint use driveway.
- F. The Planning Department may modify or waive the requirements of this section where the characteristics or layout of abutting properties would make a development of a unified or shared access and circulation system impractical. (Ord. 1043 section 3, 2000)

***Findings:*** *This criterion does not apply to this development. The Proposed street accesses have met the access separation requirements.*

#### **16.46.50 NONCONFORMING ACCESS FEATURES.**

Legal access connections in place as of April 19, 2000 that do not conform with the standards herein are considered nonconforming features and shall be brought into compliance with applicable standards under the following conditions:

- A. When new access connection permits are requested; or
- B. Change in use or enlargements or improvements that will significantly increase trip generation. (Ord. 1043 section 3, 2000)

***Findings:*** *This criterion does not apply to this development. The Proposed street accesses have met the access separation requirements.*

#### **16.46.060 AMOUNT OF ACCESS POINTS.**

In the interest of promoting unified access and circulation systems, the number of access points permitted shall be the minimum number necessary to provide reasonable access to these properties, not the maximum available for that frontage. All necessary easements, agreements, and stipulations shall be met. This shall also apply to phased development plans. The owner and all lessees within the affected area are responsible for compliance with the requirements of this ordinance and both shall be cited for any violation. (Ord 1043 section 3, 2000)

***Findings:*** *The proposed development meets or exceeds these Required Conditions. The proposed development includes four (4) strategically located access points to effectively and safely serve the development.*

#### **16.46.70 EXCEPTION STANDARDS.**

- A. An exception may be allowed from the access spacing standards if the applicant can provide proof of unique or special conditions that make strict application of the provisions impractical. Applicants shall include proof that:

1. Indirect or restricted access cannot be obtained;
  2. No engineering or construction solutions can be reasonably applied to mitigate the condition; and
  3. No alternative access is available from a street with a lower functional classification than the primary roadway.
- B. Access Management Plan Required. An applicant requesting an access exception may be required to submit an access management plan. The access management plan shall explain the need for the modification and demonstrate that the modification maintains the classified function and integrity of the facility. An access management plan shall be prepared and certified by a traffic or civil engineer registered in the State of Oregon. An access management plan shall at minimum contain the following:
1. The minimum study area shall include the length of the site's frontage plus the distance of the applicable access spacing standard, measured from each property line or access point(s), whichever is greater. For example, a property with 500 feet of frontage on an arterial (required 660 foot access spacing standard) shall have a minimum study area which is 1,820 feet in length.
  2. The potential safety and operational problems associated with the proposed access point. The access management plan shall review both existing and future access for all properties within the study area as defined above.
  3. A comparison of all alternatives examined. At a minimum, the access management plan shall evaluate the proposed modification to the access spacing standard and the impacts of a plan utilizing the City standard for access spacing. Specifically, the access management plan shall identify any impacts on the operations and/or safety of the various alternatives.
  4. A list of improvements and recommendations necessary to implement the proposed access modification, specifically addressing all safety and operational concerns identified.
  5. References to standards or publications used to prepare the access management plan.
- C. The granting of the exception shall be in harmony with the purpose and intent of these regulations and shall not be considered until every feasible option for meeting access standards is explored.
- D. No exception shall be granted where such hardship is self-created.



- E. Reasons for denying access spacing exception applications include, but are not limited to, traffic safety concerns, expected or planned traffic increases due to development or road construction, and emergency service provision issues. (Ord. 1043 section 3, 2000; Ord 1237, 2007; Ord. 1340, 2011)

**Findings:** *This criterion does not apply to this development. The Proposed development does not propose any exceptions to the standards*

#### **16.46.80 STATE HIGHWAY STANDARDS.**

- A. Refer to the Motor Vehicle Chapter of the Transportation System Plan. ODOT regulates access to OR 99E. ODOT shall review and process applications for approaches to OR 99E consistent with Oregon Highway Plan standards and OAR 734.51 procedures. An ODOT permit to operate and maintain a State Highway Approach must be approved prior to site occupancy.

**Findings:** *This criterion does not apply to this development. The Proposed development is not located along a state highway.*

#### **16.46.90 SHARED ACCESS ONTO STATE HIGHWAY.**

- A. Subdivisions with frontage on the state highway system shall be designed into shared access points to and from the highway. Normally, a maximum of two accesses shall be allowed regardless of the number of lots or businesses served. If access off of a secondary street is possible, then access should not be allowed onto the state highway. If access off of a secondary street becomes available, then conversion to that access is encouraged, along with closing the state highway access.
- B. New direct accesses to individual one- and two-family dwellings shall be prohibited on all state highways, unless doing so would deny reasonable access to an existing legal lot of record. (Ord 1043 section 3, 2000)

**Findings:** *This criterion does not apply to this development. The Proposed development is not located along a state highway.*

#### **CHAPTER 16.49 SITE AND DESIGN REVIEW**

**Findings:** *This criterion does not apply to this development. The Proposed development lies within the I-O Overlay zone. All of the requirements of the I-O Overlay zone superseded the requirements of this section.*

#### **CHAPTER 16.50 CONDITIONAL USES**

**Findings:** *This criterion does not apply to this development. The Proposed development is an outright allowed use in the M-1 zone and the I-O overlay district. No Conditional Use applications are submitted with this development.*

## **CHAPTER 16.60 PARTITIONS**

### **16.60.030 PARTITIONS**

Partition means to divide an area or tract of land into two or three parcels within the calendar year. An Application for a partition shall be evaluated based upon the following standards and criteria:

- A. Conformance with the text and applicable maps of the Comprehensive Plan;
- B. Conformance with all other applicable requirements of the Land Development and Planning Ordinance;
- C. The overall design and arrangement of parcels shall be functional and shall adequately provide building sites, utility easements, and access facilities deemed necessary for the development of the subject property without unduly hindering the use or development of adjacent properties;
- D. No partitioning shall be allowed where the sole means of access is by private road, unless it is found that adequate assurance has been provided for year-round maintenance sufficient to allow for unhindered use by emergency vehicles, and unless it is found that the construction of a street to city standards is not necessary to insure safe and efficient access to the parcels;
- E. It must be demonstrated that all required public facilities and services are available, or will become available through the development, to adequately meet the needs of the proposed land division. (Ord. 890 section 52, 1993; Ord. 740 section 10.4.30(B)(2), 1984; Ord. 1514, 2019)

**Findings:** *The proposed development meets or exceeds these Required Conditions. This application includes the partitioning of TL 300 to create 3 separate parcels. Each parcel will meet the design standards and requirements outlined in the land development code and planning ordinance. Easements will be incorporated into the individual parcels to accommodate public utility extensions, reciprocal access and other requirements that may be required by the jurisdictional authorities.*

## **CHAPTER 16.89 APPLICATION AND REVIEW PROCEDURES**

**Findings:** *The proposed development meets or exceeds these Required Conditions. This application is for a Type III Decision. Pre-Application Conference, Neighborhood Meeting, and Public Notice requirements have all been met with associated correspondence included with this application as required.*

## **CHAPTER 16.120 PARKS, OPEN SPACE, AND RECREATIONAL LAND**

### **16.120.010 PURPOSE**

The availability of park, open space, and recreation land is an important element in determining the character of a developing neighboring city to the metropolitan area, such as City of Canby. Land which substitutes trees, grass, and vegetation for structures, paving, and other urban features provides not only an aesthetically pleasing landscape with striking views of Mt. Hood, but also buffers incompatible uses, and preserves sensitive environmental features and important resources. Parks, open space, natural parks and trail recreation lands, together with support facilities, also help to meet

the active and passive recreational needs of the population of Canby; therefore, concurrent development of support facilities is equally important. This chapter implements policies of Goal 8 of the Comprehensive Plan, the Park and Recreation Master Plan, and Park and Open Space Acquisition Plan by outlining provisions for parks, open space and recreational facilities in the City of Canby.

### **16.120.20 MINIMUM STANDARD FOR PARK, OPEN SPACE AND RECREATION LAND**

**Parkland Dedication:** All new residential, commercial and industrial developments shall be required to provide park, open space and recreation sites to serve existing and future residents and employees of those developments. Multi-family developments which provide some “congregate” services and/or facilities, such as group transportation, dining halls, emergency monitoring systems, etc., but which have individual dwelling units rather than sleeping quarters only, are considered to be multi-family developments for the purpose of parkland dedication. Licensed adult congregate living facilities, nursing homes, and all other similar facilities which provide their clients with individual beds and sleeping quarters, but in which all other care and service are communal and provided by facility employees, are specifically exempt from park land dedication and system development fee requirements.

1. The required parkland shall be dedicated as a condition of approval for:

a. Approval of a tentative plat of a subdivision or partition.

**Findings:** *The proposed development does include a partition and will meet the criterion by paying the system development charge in lieu of land dedication.*

b. Approval of site and design review for all development but single-family and duplex development.

**Findings:** *The proposed development includes the implementation of a public plaza and will also pay the SDC for Parks, Open Space and Recreation Land if found to be required by the City.*

c. The replat or amendment of any site plan for multi-family development or manufactured home park where dedication has not previously been made or where the density of the development involved will be increased.

**Findings:** *This criterion does not apply to this development. The Proposed development does not include any multi-family or manufactured developments.*

2. The City shall require land dedication or payment of the system development charge (SDC) in lieu of land dedication (Section 4.20.170). In addition, the City may credit private on-site park, open space and recreation area(s) and facilities (Section 16.120.060). The City may approve any combination of these elements. Prior to parkland dedication, a Level I Environmental Assessment of the lands proposed for

dedication shall be performed by the applicant as part of the site plan approval for the project.

***Findings:*** *The proposed development includes the implementation of a public plaza and will also pay the SDC for Parks, Open Space and Recreation Land if found to be required by the City.*

The following factors shall be utilized in the City's choice of whether to accept land or cash in lieu:

1. The topography, geology, public streets access to, parcel size, shape, and location of land in the development available for dedication;
  2. Relationship of site to surrounding land uses and the surrounding transportation system;
  3. Potential adverse/beneficial effects on environmentally sensitive areas;
  4. Compatibility with the Park and Recreation Master Plan and Park and Open Space Acquisition Plan, Public Facilities element of the Comprehensive Plan, Transportation System Plan and the City of Canby Parks Capital Improvement Plan in effect at the time of dedication;
  5. Opportunity for preservation of natural and historical features, scenic viewpoints, watershed environments, and sections of land for wildlife habitat.
  6. Connections with, and continuity of, open space links, trails, and other major components of the open space system for parks.
  7. Availability of previously acquired property;
  8. Opportunity for shared use with other community facilities;
  9. Opportunity for future expansion of the site; and
  10. The feasibility of dedication.
3. Calculation of a Land Required: The total requirement of park, open space and recreational land shall be 0.01 of an acre per person based on the City standard of 10 acres of land per 1,000 residents. This standard represents the land-to-population ratio the City of Canby requires for city parks and may be adjusted periodically through amendments to the Parks and Recreation Master Plan.
- a. Population Formula: The following table of persons per unit shall be used in calculating the required dedication of acres of land:

**Table 1  
Persons per Dwelling Unit**

Type of Unit	Total Persons Per Unit
Single Family Residential	2.7
Standard Multi-family Unit	2.0
Manufactured dwelling park	2.0
Congregate multi-family unit	1.5

Persons per unit, age distribution, and local conditions change with time. The specific formula for the dedication of land will, therefore, be subject to periodic review and amendment.

- b. Determination of Resident Population: The projected resident population of the land to be subdivided or developed is determined by multiplying the maximum number of units allowed by the plat or the site plan by the appropriate number of standard of persons per unit set forth in Table 1 above. This figure is then to be multiplied by 0.01 to determine the total acreage that must be dedicated or deeded to the City for park, open space or recreation

$$(\text{Maximum units}) \times (\text{persons/unit}) \times 0.01 \text{ (acreage to be dedicated)}$$

**16.120.30 DEDICATION PROCEDURES**

When the final plat or site plan is approved, the developer shall dedicate the land as previously determined by the City in conjunction with approval of the tentative plat or site plan. Dedication of land in conjunction with multi-family development shall be required prior to issuance of permits and commencement of construction.

Dedication of land or covenants approved as part of a preliminary plat or site plan approval may be given or provided when the final plat is presented for approval. The developer must clear, or fill and grade all parkland to be dedicated to the satisfaction of the City and shall cause a Level I Environmental Assessment, as referenced by Section 16.120.020 Minimum standards for park, open space, and recreation land of this Code, to be performed on all lands to be dedicated as part of the City’s construction plan approval for the plat.

- A. In addition to a formal dedication on the plat or site plan to be recorded, the subdivider shall convey the required lands to the City by general warranty deed. The developer of a multi-family development or manufactured home park shall deed the lands required to be dedicated by a general warranty deed. In any of the above situations, the land so dedicated and deeded shall not be subject to any reservations of record, encumbrances of any kind or easement which, in the opinion of the Planning Director, will interfere with the use of the land for park, open space or recreational purposes.

If any questions exists as the presence of any reservation, encumbrances or easements, the subdivider or developer may be required to present to the City a title insurance policy on the subject property ensuring the marketable state of the title.

- B. Where any reservation, encumbrances or easements exist, the City shall require payment in lieu of the dedication of lands (see Section 16.120.040 Cash in lieu of dedication below) unless the City chooses to accept the land subject to encumbrances.
- C. If the developer does not own the property held subject to the land dedication the Planning Commission may, at its discretion, approve the grant of a long-term lease of land, which will satisfy the intent of the parkland dedication provisions set forth within this Code.
- D. Trails that are to be dedicated that are within the floodway of a 100-year floodplain shall be credited no more than 25% of land dedication requirements. Trails that are to be dedicated that are not within the floodway, but are within the 100-year floodplain, or which are part of irrigation ditches or stormwater detention areas shall be credited no more than 50% of land dedication requirement. No other land dedicated in a floodplain shall receive any credit.

***Findings:** This criterion does not apply to this development as the development will be paying the system development charge in lieu of coordinating the dedication of parkland property.*

#### **16.120.40 CASH IN LIEU OF DEDICATION OF LAND**

In no case shall land dedication requirements be in excess of 15 percent of the gross land area of the development without the agreement of the developer. The decision of whether land is acceptable for use by the public for park and recreation purposes is to be made by the City Planning Commission based on the findings and planning set forth in the Canby Park and Recreation Master Plan and Acquisition Plan. Formal acceptance of parks and recreation lands required to be dedicated shall be by the City Council following any land use hearing and recommendation by the City Planning Commission. In all cases, except for PUD's, actual dedication of land shall occur prior to final plat sign-off. Dedication of land in the case of a PUD shall occur, by separate instrument, prior to commencement of construction of the project.

If land proposed for dedication to the public does not meet the criteria set forth in the Canby Park and Open Space Acquisition Plan, then at the option of the city, a park system development charge shall be required. Once calculated, the dedication of land shall remain the same, and not change, unless the original plans are altered.

- A. Procedures for Land Dedication. Development applications shall include a scaled plan which identifies the sites proposed to be dedicated as park land. Parkland and recreational sites shall be clearly and accurately depicted on the final plat map and documented in the tax lot files. All phased residential subdivisions and planned unit developments shall show any proposed parkland for dedication on the overall master plan plat for the proposed development in addition to other anticipated public facilities. Such master plan as finally approved and accepted by the Planning Commission is considered binding on all future phases. Any requests by the developer to change parkland dedication for future phases must be brought back to the Commission for approval. In case of phased development where

separate plats are recorded, land dedication shall occur prior to final platting of forty percent of the gross land area.

Tentative approval of parkland boundaries shall be made by the hearing body at the time of the public hearing on the development proposal. All sites shall be dedicated in a condition ready for full service including electrical, water, sewer and streets as is applicable to the location of the site or as necessary infrastructure and/or improvements to adjacent sites can be made at the discretion of the city. In case of phased development, sites may be improved as each phased is developed rather than at the time of original dedication. An environmental audit sufficient to meet DEQ requirements shall be required on all parkland proposed to be dedicated to the city prior to acceptance. The cost of such an audit shall be split equally between the city and the developer.

All lands dedicated to the city for parkland and recreational space shall be conveyed to the city either by warranty deed or be depicted on the final recorded plat as so dedicated. The conveyor shall be responsible for payment of all title searches, real estate taxes, and recording fees at the time of conveyance.

- B. Options for Meeting System Development Charge Requirements. Any land proposed or required for parkland dedication, including improvements thereon, shall be appraised at its fair market value at the time it is dedicated to the city. The cost of the appraisal shall be divided equally between the developer and the city. This value of the property shall be credited toward the system development charge calculated for the development with the difference being the cash owed the System Development Improvement Fund. In no case may the city require more land of the developer than would be required if the entire amount of the system development charge was paid in cash. Similarly, no developer may dedicate parkland above the valuation required by the system development charge so that the city would be required to refund money to the developer unless mutually agreed upon by the city and developer.

If no parkland dedication is required or requested by the city, the full amount of the park system development charge will be assessed and is due and payable at the time the first building permit(s) is/are issued.

- a. Cash charged in lieu of land dedication shall be based on the City's System Development Charge for parkland, as provided by the Systems Development Charge ordinance.
- b. Cash in lieu of parkland dedication may be paid in installments on a per building basis for multi-family development or a per lot basis for platted single family or duplex subdivisions. Payment must be made in full for each building or lot in conjunction with construction permits.

***Findings:*** *The proposed development includes the implementation of a public plaza, but will pay the SDC for Parks, Open Space and Recreation Land if found to be required by the City.*

**16.120.050 REVIEW PROCEDURE**

Decisions made for section 16.120.020 Minimum standards for park, open space and recreation land and Section 16.120.030 Dedication procedures shall be made by the Planning Director for Type I and Type II decisions and by the Planning Commission for Type III decisions. The applicant shall have full rights of appeal to the Planning Commission or City Council according to procedures set forth in Division VIII General Standards and Procedures.

**16.120.60 PARTIAL CREDIT FOR PRIVATE PARK, OPEN SPACE AND RECREATIONAL FACILITIES/AREAS:**

Where a substantial private park and recreational area is provided in a proposed residential development and such space is to be privately owned and maintained by the future residents of the development, partial credit, not to exceed 50% may be given against the dedication if the Planning Commission finds that it is in the public interest to do so and that all the following standards are met:

1. That yards, court areas, and setbacks required to be maintained by the zoning and building ordinances and regulations shall not be included in the computation of such private parkland.
2. That the private ownership and maintenance of the parkland is adequately provided for by recorded written agreement, conveyance or restrictions.
3. That the use of the private parkland is restricted for park and recreational purposes by recorded covenant, which runs with the land in favor of the future owners of property and which cannot be defeated or eliminated without the consent of the City or its successor.
4. That the proposed private parkland is reasonably adaptable for use for park and recreational purposes, taking into consideration such factors as size, shape, topography, geology, access and location.
5. That facilities proposed for the parkland are in substantial accordance with the provision of the Canby Park and Recreation Master Plan and Canby Park and Open Space Acquisition Plan and,
6. That the parkland for which credit is given is a minimum of two acres and provides a minimum of three of the basic local park elements listed below, or a combination of such and other recreational improvements that will meet the specific recreation park needs of the future residents of the area:

<b>CRITERIA LIST</b>	<b>ACRES</b>
Children’s play apparatus area	.50 - .75
Landscaped park-like and quiet areas	.50 - 1.00
Family picnic area	.25 - .75
Game court area	.25 - .50



Turf play field	1.00 - 3.00
Recreation center building	.15 - .25
Swimming pool (42' x 75') w/adjacent deck and lawn area	.25 - .50
Recreation and community gardening	.15 - .25

Before credit is given, the Planning Commission shall make written findings that the above standards are met.

***Findings:*** *The proposed development includes the implementation of a public plaza, but will pay the SDC for Parks, Open Space and Recreation Land if found to be required by the City.*















**D-Series Size 1 LED Area Luminaire**

**Specifications**  
EPA: 1.01 ft<sup>2</sup>  
Length: 33"  
Width: 13"  
Height H1: 7-1/2"  
Height H2: 3-1/2"  
Weight (max): 27 lbs

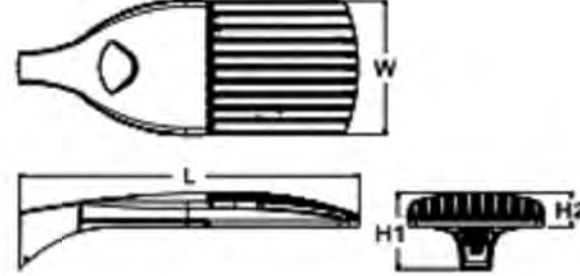

**Introduction**  
The modern styling of the D-Series is striking yet unobtrusive - making a bold, progressive statement even as it blends seamlessly with its environment. The D-Series distills the benefits of the latest in LED technology into a high-performance, high efficacy, long-life luminaire. The outstanding photometric performance results in sites with excellent uniformity, greater pole spacing and lower power density. It is ideal for replacing up to 750W metal halide in pedestrian and area lighting applications with typical energy savings of 65% and expected service life of over 100,000 hours.

**Ordering Information** EXAMPLE: DSX1 LED P7 40K T3M MVOLT SPA NLTAIR2 PIRHN DOBXD

Series	LEDs	Color Temperature	Beam Spread	Mounting	Shipping/Included
DSX1 LED	P1 P4 P7	40K 5000K	T15 Spot/short	100'	<b>SHIPPED INCLUDED</b> SPR Square pole mounting RMA Round pole mounting RMAA Round pole mounting adapter* RPBMA Round pole mounting adapter* RPBMAA Round pole mounting adapter* <b>SHIPPED SEPARATELY</b> RMAA R0000* High precision black adaptive (body/black)
	P2 P5 P6 P9	50K 5000K	T25 Spot/short	200'	
Related optics	P10 P12	40K 5000K	T35 Spot/short	340'	RPBMAA Square pole mounting adapter* RPBMAA Round pole mounting adapter*
	P11 P13	40K 5000K	T35 Spot/short	377'	
Control options	P14 P15	40K 5000K	T35 Spot/short	347'	RPBMAA Square pole mounting adapter* RPBMAA Round pole mounting adapter*
	P16 P17	40K 5000K	T35 Spot/short	400'	

Control options	Optical options	Finish options
<b>SHIPPED INSTALLED</b> NLTAIR2 Light off position 2-wire PIRHN Network Light fixture ambient sensor PER NSMA Sensor lock (not available on all optics) PER5 Five-gang receptacle only (not available on all optics) PER7 Sensor photo eye (not available on all optics) DMS On the ground sensor (not available on all optics) DS Dual mounting	PIR High flow, non-ambient sensor, 8-15' mounting height, ambient sensor enabled at 3" PIRN High flow, non-ambient sensor, 15-30' mounting height, ambient sensor enabled at 3" PIRHFCV High flow, non-ambient sensor, 8-15' mounting height, ambient sensor enabled at 3" PIRHFCV High flow, non-ambient sensor, 15-30' mounting height, ambient sensor enabled at 3" FAD Field adjustable output*	<b>SHIPPED INSTALLED</b> H5 Black SF Single-finish (133, 277, 347)* DF Double-finish (200, 240, 400)* LW Left-hand optics RW Right-hand optics <b>SHIPPED SEPARATELY</b> RPBMAA Round pole mounting adapter* RPBMAA Round pole mounting adapter* RPBMAA Round pole mounting adapter* RPBMAA Round pole mounting adapter* RPBMAA Round pole mounting adapter*

LITHONIA LIGHTING One Lithonia Way • Conley, Georgia 30012 • Phone: 800.279.8011 • www.lithonia.com  
© 2011-2018 Acuity Brands Lighting, Inc. All rights reserved.

**ILLUMINANCE RESULTS**

	Average	Maximum	Minimum	Avg/Min	Max/Min
Area 1	3.8 fc	16.5 fc	0.0 fc	5110141857.2	22388753834.8
Area 2	3.0 fc	8.4 fc	0.0 fc	120015.7	333791.0
Area 3	3.1 fc	10.8 fc	0.0 fc	684768812.5	2391647144.3
Area 4	3.0 fc	10.1 fc	0.0 fc	5744007.8	19029377.4
S. 1ST AVENUE @	1.2 fc	6.3 fc	0.0 fc	38.2	199.5
S. WALNUT STREET @	2.5 fc	6.5 fc	0.0 fc	66.0	167.8

NOTE: ONSITE AREAS HAVE BEEN DIVIDED EQUALLY FOR COMPUTER PROCESSING.

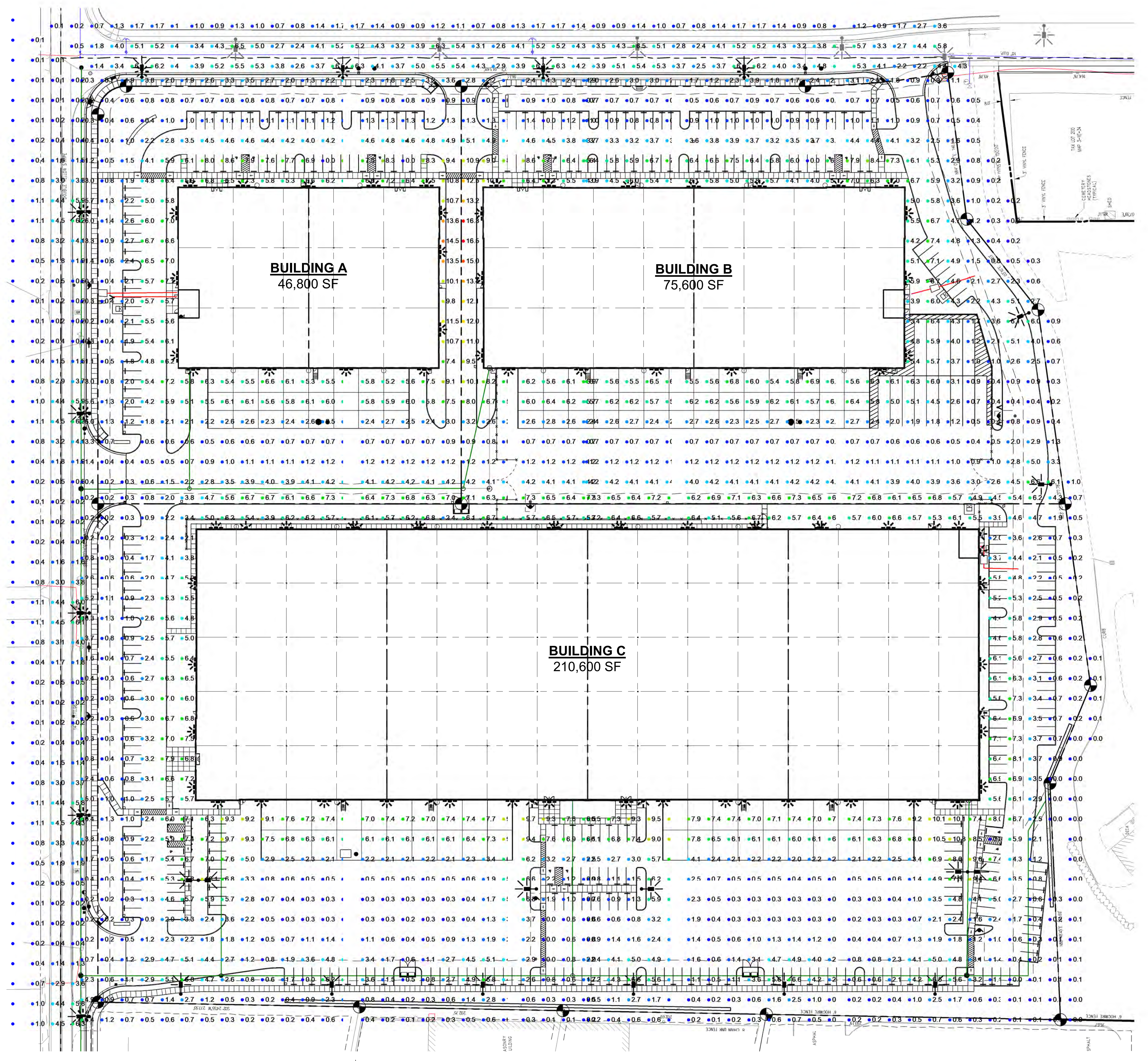

**1 LIGHTING PLAN**  
G2.0  
1" = 50'-0"  
0 50 100 150

Trammell Crow Company

PROJECT NAME  
**BAKER CENTER**  
MASTER PLAN

S. 1ST AVENUE AND  
S. WALNUT STREET  
CANBY, OR 97013

REVISIONS

DATE	DESCRIPTION

FOR REFERENCE ONLY  
NOT FOR CONSTRUCTION

DATE	MAY, 2020
SCALE	AS NOTED
PROJ. NO.	20180346
DRAWN	GJB
CHECKED	BWH

**SITE LIGHTING PLAN**

**G2.0**











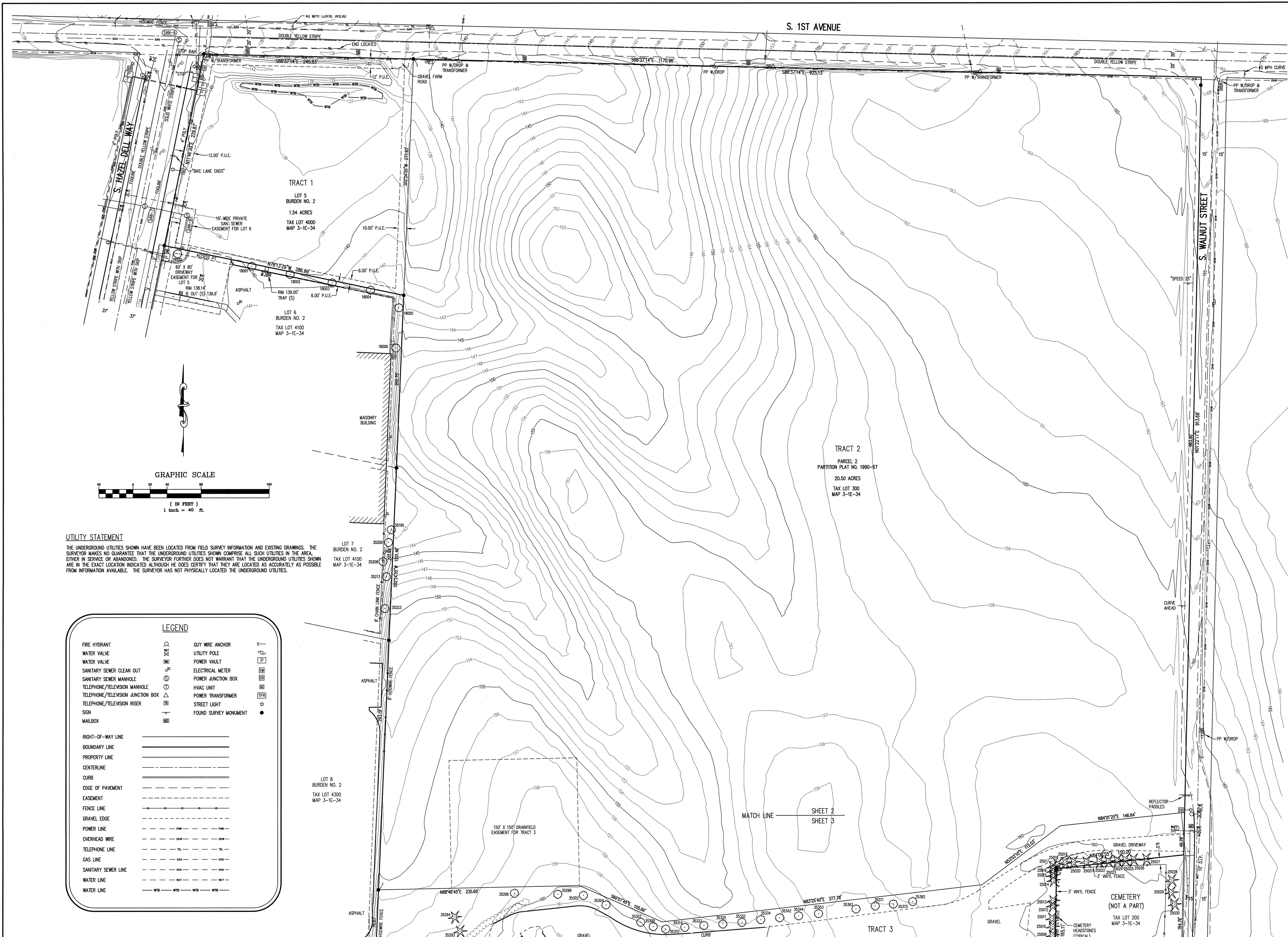

**NORTHWEST SURVEYING, Inc.**  
 1815 NW Adams St., Suite 2090  
 Beaverton, OR 97005  
 Phone: 503-645-2127 Fax: 503-645-848-2179  
 Email: nwsurveying@nwsurvey.com

LOCATED IN THE EAST 1/2 OF SECTION 34,  
 TOWNSHIP 3 SOUTH, RANGE 1 EAST, W.M.,  
 CITY OF CANBY,  
 CLACKAMAS COUNTY, OREGON

**TOPOGRAPHIC SURVEY**  
**OREGON**  
**CANBY,**

DRAWING NO.: 1838 TOPO  
 SCALE: AS NOTED  
 DRAWING GENERATED BY: 102004  
 DRAWN BY: SFT  
 CHECKED BY: CHS  
**PREPARED FOR:**  
 TRAMMELL CROW COMPANY  
 1300 SW FIFTH AVE., STE 3050  
 PORTLAND, OR 97201

**REVISIONS:**  
 INITIAL RELEASE: OCT. 22, 2016

REGISTERED PROFESSIONAL LAND SURVEYOR  
*Scott F. Field*  
 OREGON  
 JUNE 30, 1997  
 SCOTT F. FIELD  
 2844  
 12-31-2019  
 RENEWAL DATE

JOB NUMBER  
**1838**  
 SHEET  
**1 OF 2**

**UTILITY STATEMENT**  
 THE UNDERGROUND UTILITIES SHOWN HAVE BEEN LOCATED FROM FIELD SURVEY INFORMATION AND EXISTING DRAWINGS. THE SURVEYOR MAKES NO GUARANTEE THAT THE UNDERGROUND UTILITIES SHOWN COMPRISE ALL SUCH UTILITIES IN THE AREA EITHER IN SERVICE OR ABANDONED. THE SURVEYOR FURTHER DOES NOT WARRANT THAT THE UNDERGROUND UTILITIES SHOWN ARE IN THE EXACT LOCATION INDICATED ALTHOUGH HE DOES CERTIFY THAT THEY ARE LOCATED AS ACCURATELY AS POSSIBLE FROM INFORMATION AVAILABLE. THE SURVEYOR HAS NOT PHYSICALLY LOCATED THE UNDERGROUND UTILITIES.

LEGEND	
FIRE HYDRANT	⊙
WATER VALVE	⊕
WATER VALVE	⊖
SANITARY SEWER CLEAN OUT	⊙
SANITARY SEWER MANHOLE	⊕
TELEPHONE/TELEVISION MANHOLE	⊖
TELEPHONE/TELEVISION JUNCTION BOX	⊙
TELEPHONE/TELEVISION RISER	⊕
SIGN	⊖
MAILBOX	⊙
GUY WIRE ANCHOR	↑
UTILITY POLE	⊕
POWER VAULT	⊖
ELECTRICAL METER	⊙
POWER JUNCTION BOX	⊕
HVAC UNIT	⊖
POWER TRANSFORMER	⊙
STREET LIGHT	⊕
FOUND SURVEY MONUMENT	●
RIGHT-OF-WAY LINE	———
BOUNDARY LINE	———
PROPERTY LINE	———
CENTERLINE	———
CURB	———
EDGE OF PAVEMENT	———
EASEMENT	———
FENCE LINE	———
GRAVEL EDGE	———
POWER LINE	———
OVERHEAD WIRE	———
TELEPHONE LINE	———
GAS LINE	———
SANITARY SEWER LINE	———
WATER LINE	———
WATER LINE	———

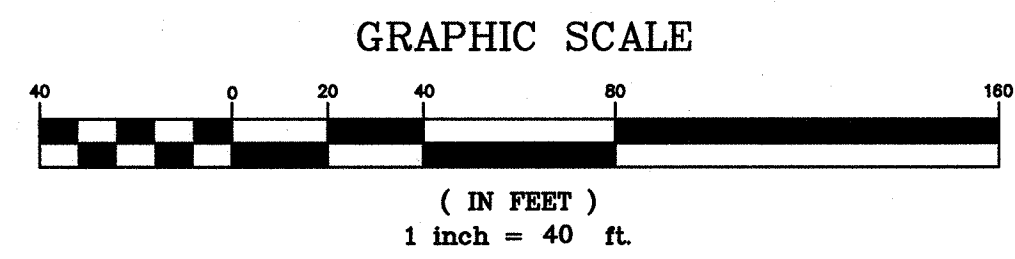

**TRACT 1**  
 LOT 5  
 BURDEN NO. 2  
 1.54 ACRES  
 TAX LOT 4000  
 MAP 3-1E-34

**LOT 6**  
 BURDEN NO. 2  
 TAX LOT 4100  
 MAP 3-1E-34

**LOT 7**  
 BURDEN NO. 2  
 TAX LOT 4100  
 MAP 3-1E-34

**LOT 8**  
 BURDEN NO. 2  
 TAX LOT 4300  
 MAP 3-1E-34

**TRACT 2**  
 PARCEL 2  
 PARTITION PLAT NO. 1990-67  
 20.50 ACRES  
 TAX LOT 300  
 MAP 3-1E-34

**TRACT 3**

MATCH LINE  
 SHEET 2  
 SHEET 3

**CEMETERY**  
 (NOT A PART)  
 TAX LOT 200  
 MAP 3-1E-34  
 CEMETERY HEADSTONES (TYPICAL)



LOT 8  
BURDEN NO. 2  
TAX LOT 4300  
MAP 3-1E-34

LOT 9  
BURDEN NO. 2  
TAX LOT 4400  
MAP 3-1E-34

LOT 12  
BURDEN NO. 2  
TAX LOT 4700  
MAP 3-1E-34

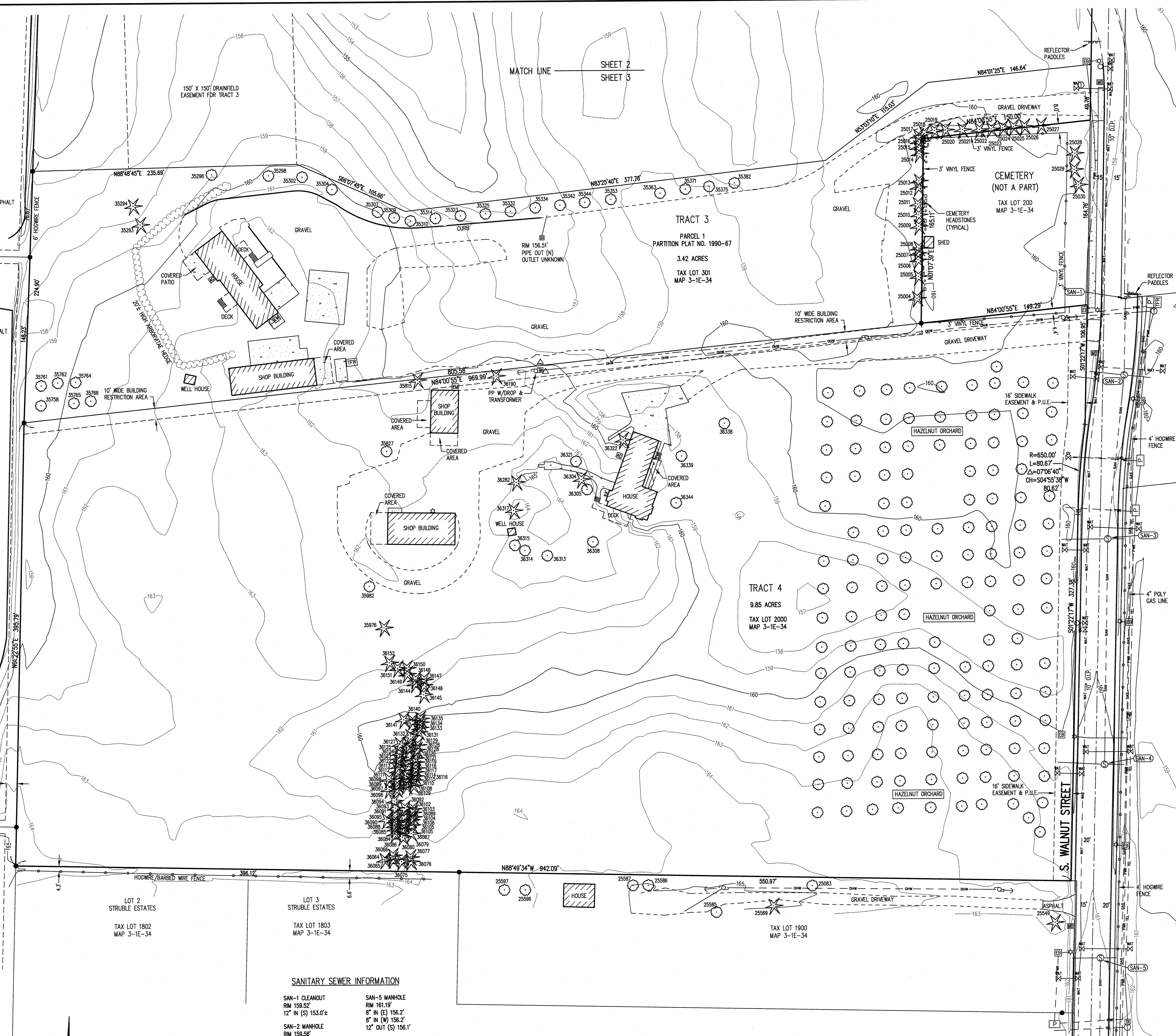

### LEGEND

FIRE HYDRANT	⊙	GUY WIRE ANCHOR	⊥
WATER VALVE	⊕	UTILITY POLE	⊥
WATER VALVE	⊕	POWER VAULT	⊥
SANITARY SEWER CLEAN OUT	⊕	ELECTRICAL JUNCTION	⊥
SANITARY SEWER MANHOLE	⊕	POWER JUNCTION BOX	⊥
TELEPHONE/TELEVISION MANHOLE	⊕	HVAC UNIT	⊥
TELEPHONE/TELEVISION JUNCTION BOX	⊕	POWER TRANSFORMER	⊥
TELEPHONE/TELEVISION RISER	⊕	STREET LIGHT	⊥
SIGN	⊕	FOUND SURVEY MONUMENT	⊕
MAILBOX	⊕		

RIGHT-OF-WAY LINE	———
BOUNDARY LINE	———
PROPERTY LINE	———
CENTERLINE	———
CURB	———
EDGE OF PAVEMENT	———
EASEMENT	———
FENCE LINE	———
GRAVEL EDGE	———
POWER LINE	———
OVERHEAD WIRE	———
TELEPHONE LINE	———
GAS LINE	———
SANITARY SEWER LINE	———
WATER LINE	———
WATER LINE	———

### TREE INFORMATION

18000	9" DEODOUOS	35307	20" MAPLE	36106	5" FIR
18001	6" DEODOUOS	35309	18" MAPLE	36108	16" FIR
18002	8" DEODOUOS	35310	17" MAPLE	36109	6" FIR
18003	8" DEODOUOS	35314	17" MAPLE	36110	12" FIR
18004	7" DEODOUOS	35323	16" MAPLE	36111	8" FIR
18005	8" DEODOUOS	35325	15" MAPLE	36112	7" FIR
18006	9" DEODOUOS	35332	15" MAPLE	36113	8" FIR
25004	3 1/2" FIR	35334	19" MAPLE	36114	8" FIR
25005	27" FIR	35342	24" MAPLE	36115	5" FIR
25006	32" FIR	35344	18" MAPLE	36116	12" FIR
25007	20" FIR	35345	19" MAPLE	36117	9" FIR
25008	17" FIR	35363	14" MAPLE	36118	7" FIR
25009	27" FIR	35371	17" MAPLE	36119	10" FIR
25010	18" FIR	35375	18" MAPLE	36120	11" FIR
25011	32" FIR	35382	27" MAPLE	36121	10" FIR
25012	24" FIR	35758	21" POPLAR	36122	5" FIR
25013	25" FIR	35761	11" POPLAR	36123	11" FIR
25014	18" FIR	35762	9" APPLE	36124	8" FIR
25015	28" FIR	35764	16" CHERRY	36125	6" FIR
25016	14" FIR	35765	25" CHERRY	36126	6" FIR
25017	19" FIR	35766	8" APPLE	36127	11" FIR
25018	20" FIR	35815	17" FIR	36128	12" FIR
25019	17" FIR	35827	21" WALNUT	36129	15" FIR
25020	24" FIR	35876	13" FIR	36131	11" FIR
25021	27" FIR	35882	15" MAPLE	36132	9" FIR
25022	24" FIR	36064	18" FIR	36133	10" FIR
25023	18", 19" FIR	36065	18" FIR	36134	13" FIR
25024	21" FIR	36066	14" FIR	36135	16" FIR
25025	24" FIR	36075	16" FIR	36140	10" FIR
25026	22" FIR	36076	23" FIR	36141	9" FIR
25027	20" FIR	36077	15" FIR	36144	10" FIR
25028	47" FIR	36079	17" FIR	36145	20" FIR
25029	53" FIR	36080	7" FIR	36146	15" FIR
25030	60" FIR	36084	7" FIR	36147	14" FIR
25083	20" DEODOUOS	36085	5" FIR	36148	7" FIR
25449	57" FIR	36086	9" FIR	36149	11" FIR
25569	25" FIR	36087	7" FIR	36150	22" FIR
25585	29" DEODOUOS	36088	9" FIR	36151	7" FIR
25586	(2)6", 10", 11" DEODOUOS	36089	10" FIR	36152	19" FIR
25587	6", 7", 8", 10" DEODOUOS	36090	5" FIR	36150	23" PINE
25588	7" APPLE	36091	5" FIR	36282	10" FIR
25597	10" APPLE	36092	5" FIR	36304	25" FIR
36186	6", (3)8", (2)8" COTTONWOOD	36093	9" FIR	36305	14" MAPLE
36200	5" DEODOUOS	36094	10" FIR	36306	13" CHERRY
36208	10", 12" COTTONWOOD	36095	13" FIR	36313	7", 8" MAPLE
36213	8" DEODOUOS	36096	8" FIR	36314	10" DEODOUOS
36223	6" DEODOUOS	36097	11" FIR	36315	(3) 7" MAPLE
36283	21" HEMLOCK	36098	12" FIR	36317	46" CEDAR
36294	14" HEMLOCK	36099	5" FIR	36321	10" MAGNOLIA
36296	43" WALNUT	36102	9" FIR	36322	13" FIR
36298	25" MAPLE	36103	14" FIR	36338	14" APPLE
36302	17" MAPLE	36104	14" FIR	36339	12" DEODOUOS
36304	27" MAPLE	36105	14" FIR	36344	35" MAPLE

### SANITARY SEWER INFORMATION

SAN-1 CLEANOUT RM 159.92' 12" IN (S) 153.0'±	SAN-5 MANHOLE RM 161.19' 8" IN (E) 156.2' 8" IN (W) 156.2'
SAN-2 MANHOLE RM 158.56' 8" IN (E) 153.3' 8" IN (W) 153.3' 12" IN (S) 153.3' 12" OUT (N) 153.1'	SAN-6 MANHOLE RM 140.20' 8" IN (S) 129.5' 8" OUT (W) 129.3'
SAN-3 MANHOLE RM 158.36' 8" IN (W) 153.6' 8" IN (E) 153.7' 12" IN (S) 153.6' 12" OUT (N) 153.6'	SAN-7 MANHOLE RM 139.22' 8" IN (E) 130.7' 8" IN (W) 130.7' 8" IN (S) 130.6' 8" OUT (N) 130.4'
SAN-4 MANHOLE RM 163.35' 8" IN (W) 154.3' 8" IN (E) 154.1' 12" OUT (N) 154.0'	SAN-8 MANHOLE RM 137.75' 8" IN (S) 8" OUT (W) UNABLE TO ACCESS

NOTE: PER OBSERVED EVIDENCE & CITY OF CANBY AS-BUILT DRAWINGS, THE SANITARY SEWER PIPES AND STRUCTURES NORTH OF SAN-4 ARE NOT CONNECTED TO THE CITY SEWER NETWORK.

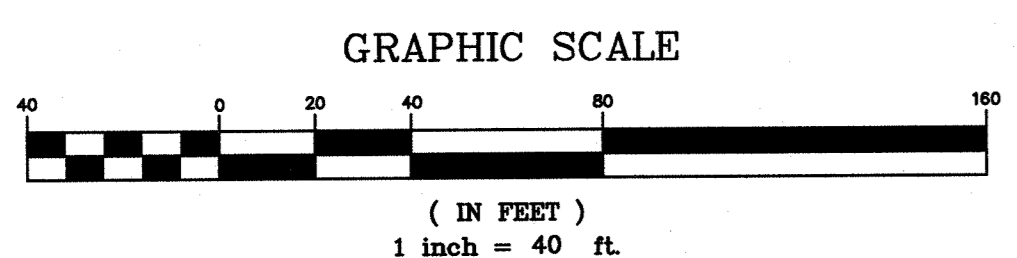

**ORTHWEST SURVEYING, Inc.**  
1815 NW 168th PLACE, SUITE 2090  
BEAVERTON, OR 97006  
PHONE: 503-448-2127, FAX: 503-648-2179  
EMAIL: info@orthwestsurveying.com

LOCATED IN THE EAST 1/2 OF SECTION 34,  
TOWNSHIP 3 SOUTH, RANGE 1 EAST, W.M.,  
CITY OF CANBY,  
CLACKAMAS COUNTY, OREGON

**TOPOGRAPHIC SURVEY**  
**OREGON**  
**CANBY,**

DRAWING NO.: 1838 TOPO  
SCALE: AS NOTED  
DRAWING GENERATED BY: 102004  
DRAWN BY: SFT  
CHECKED BY: CHS  
**PREPARED FOR:**  
TRAMMELL GROW COMPANY  
1300 SW FIFTH AVE., STE 3050  
PORTLAND, OR 97201

REVISIONS:  
INITIAL RELEASE: OCT. 22, 2018

REGISTERED PROFESSIONAL LAND SURVEYOR  
*Scott F. Field*  
OREGON  
JUNE 30, 1997  
SCOTT F. FIELD  
2844  
12-31-2019  
RENEWAL DATE

JOB NUMBER  
**1838**  
SHEET  
**2 OF 2**

**UTILITY STATEMENT**  
THE UNDERGROUND UTILITIES SHOWN HAVE BEEN LOCATED FROM FIELD SURVEY INFORMATION AND EXISTING DRAWINGS. THE SURVEYOR MAKES NO GUARANTEE THAT THE UNDERGROUND UTILITIES SHOWN COMPRISE ALL SUCH UTILITIES IN THE AREA, EITHER IN SERVICE OR ABANDONED. THE SURVEYOR FURTHER DOES NOT WARRANT THAT THE UNDERGROUND UTILITIES SHOWN ARE IN THE EXACT LOCATION INDICATED ALTHOUGH HE DOES CERTIFY THAT THEY ARE LOCATED AS ACCURATELY AS POSSIBLE FROM INFORMATION AVAILABLE. THE SURVEYOR HAS NOT PHYSICALLY LOCATED THE UNDERGROUND UTILITIES.

- NOTES**
- FIELD WORK WAS PERFORMED IN SEPTEMBER/OCTOBER 2018.
  - THE HORIZONTAL BASIS OF BEARINGS IS THE OREGON STATE PLANE COORDINATE SYSTEM (NORTH ZONE) NAD 83/91.
  - ELEVATIONS ARE GPS DERIVED AND ON THE NAVD 1988 VERTICAL DATUM.
  - EASEMENTS AS SHOWN ARE PER TITLE REPORTS PREPARED BY CHICAGO TITLE COMPANY OF OREGON AS FOLLOWS:  
TRACT 1 - ORDER NO. 472518001882 WITH AN EFFECTIVE DATE OF APRIL 17, 2018  
TRACT 2 - ORDER NO. 472518001869 WITH AN EFFECTIVE DATE OF JUNE 13, 2018  
TRACT 3 - ORDER NO. 472518001865 WITH AN EFFECTIVE DATE OF APRIL 13, 2018  
TRACT 4 - ORDER NO. 472518001779 WITH AN EFFECTIVE DATE OF APRIL 10, 2018











**OUTLINE SPECIFICATIONS PLANTING AND SEEDING:**

**GENERAL:** All plants shall conform to all applicable standards of the latest edition of the "American Association of Nurserymen Standards", A.N.S.I. Z60.1 - 1973. Meet or exceed the regulations and laws of Federal, State, and County regulations, regarding the inspection of plant materials, certified as free from hazardous insects, disease, and noxious weeds, and certified fit for sale in Oregon.

The apparent silence of the Specifications and Plans as to any detail, or the apparent omission from them of a detailed description concerning any point, shall be regarded as meaning that only the best general practice is to prevail and that only material and workmanship of first quality are to be used. All interpretations of these Specifications shall be made upon the basis above stated.

Landscape contractor shall perform a site visit prior to bidding to view existing conditions.

**PERFORMANCE QUALITY ASSURANCE:** Use adequate numbers of skilled workmen who are thoroughly trained and experienced in the necessary horticultural practices and who are completely familiar with the specified requirements and methods needed for the proper performance of the work of this section.

**NOTIFICATION:** Give Landscape Architect minimum of 2 days advance notice of times for inspections. Inspections at growing site does not preclude Landscape Architect's right of rejection of deficient materials at project site. Each plant failing to meet the above mentioned "Standards" or otherwise failing to meet the specified requirements as set forth shall be rejected and removed immediately from the premises by the Contractor and at his expense, and replaced with satisfactory plants or trees conforming to the specified requirements.

**SUBSTITUTIONS:** Only as approved by the Landscape Architect or the Owner's Representative.

**GUARANTEE AND REPLACEMENT:** All plant material shall be guaranteed from final acceptance for one full growing season or one year, whichever is longer. During this period the Contractor shall replace any plant material that is not in good condition and producing new growth (except that material damaged by severe weather conditions, due to Owner's negligence, normally unforeseen peculiarities of the planting site, or lost due to vandalism). Guarantee to replace, at no cost to Owner, unacceptable plant materials with plants of same variety, age, size and quality as plant originally specified. Conditions of guarantee on replacement plant shall be same as for original plant.

Landscape Contractor shall keep on site for Owner's Representative's inspection, all receipts for soil amendment and topsoil deliveries.

**PROTECTION** Protect existing roads, sidewalks, and curbs, landscaping, and other features remaining as final work. Verify location of underground utilities prior to doing work. Repair and make good any damage to service lines, existing features, etc. caused by landscaping installation.

**PLANT QUALITY ASSURANCE:** Deliver direct from nursery. Maintain and protect roots of plant material from drying or other possible injury. Store plants in shade and protect them from weather immediately upon delivery, if not to be planted within four hours.

Nursery stock shall be healthy, well branched and rooted, formed true to variety and species, full foliated, free of disease, injury, defects, insects, weeds, and weed roots. Trees shall have straight trunks, symmetrical tips, and have an intact single leader. Any trees with double leaders will be rejected upon inspection. All Plants: True to name, with one of each bundle or lot tagged with the common and botanical name and size of the plants in accordance with standards of practice of the American Association of Nurserymen, and shall conform to the Standardized Plant Names, 1942 Edition.

Container grown stock: Small container-grown plants, furnished in removable containers, shall be well rooted to ensure healthy growth. **Grow container plants in containers a minimum of one year** prior to delivery, with roots filling container but not root bound. Bare root stock: Roots well-branched and fibrous. Balled and burlapped (B&B): Ball shall be of natural size to ensure healthy growth. Ball shall be firm and the burlap sound. No loose or made ball will be acceptable.

**TOPSOIL AND FINAL GRADES:** Landscape Contractor is to supply and place 12" of topsoil in planting beds and 6" in lawn areas. Landscape Contractor is to verify with the General Contractor if the on-site topsoil is or is not conducive to proper plant growth. The topsoil shall be a sandy loam, free of all weeds and debris inimical to lawn or plant growth. Furnish soil analysis by a qualified soil testing laboratory stating percentages of organic matter; gradation of sand, silt and clay content; cation exchange capacity; deleterious material; pH; and plant nutrient content of the topsoil. Report suitability of topsoil for plant growth and recommended quantities of nitrogen, phosphorus and potash nutrients and soil amendments (including compost) to be added to produce satisfactory topsoil. If stockpiled topsoil on site is not conducive to proper plant growth, the Landscape Contractor shall import the required amount.

Landscaping shall include finished grades and even distribution of topsoil to meet planting requirements. Grades and slopes shall be as indicated. Planting bed grades shall be approximately 3" below adjacent walks, paving, finished grade lines, etc., to allow for bark application. Finish grading shall remove all depressions or low areas to provide positive drainage throughout the area.

**PLANTING SPECIFICATIONS:**

**HERBICIDES:** Prior to soil preparation, all areas showing any undesirable weed or grass growth shall be treated with Round-up in strict accordance with the manufacturer's instructions.

**SOIL PREPARATION:** Work all areas by rototilling to a minimum depth of 8". Remove all stones (over 1 1/2" size), sticks, mortar, large clumps of vegetation, roots, debris, or extraneous matter turned up in working. Soil shall be of a homogeneous fine texture. Level, smooth and lightly compact area to plus or minus .10 of required grades.

In groundcover areas add 2" of compost (or as approved) and till in to the top 6" of soil.

**PLANTING HOLE:** Lay out all plant locations and excavate all soils from planting holes to 2 1/2 times the root ball or root system width. Loosen soil inside bottom of plant hole. Dispose of any "subsoil" or debris from excavation. Check drainage of planting hole with water, and adjust any area showing drainage problems.

**SOIL MIX:** Prepare soil mix in each planting hole by mixing:  
2 part native topsoil (no subsoil)  
1 part compost (as approved)

Thoroughly mix in planting hole and add fertilizers at the following rates:  
Small shrubs - 1/8 lb./plant  
Shrubs - 1/3 to 1/2 lb./plant  
Trees - 1/3 to 1 lb./plant

**FERTILIZER:** For trees and shrubs use Commercial Fertilizer "A" Inorganic (5-4-3) with micro-nutrients and 50% slow releasing nitrogen. For initial application in fine seed lawn areas use Commercial Fertilizer "B" (8-16-8) with micro-nutrients and 50% slow-releasing nitrogen. For lawn maintenance use Commercial Fertilizer "C" (22-16-8) with micro-nutrients and 50% slow-releasing nitrogen.

**PLANTING TREES AND SHRUBS:** Plant upright and face to give best appearance or relationship to adjacent plants and structures. Place 6" minimum, lightly compacted layer of prepared planting soil under root system. Loosen and remove twine binding and burlap from top 1/2 of root balls. Cut off cleanly all broken or frayed roots, and spread roots out. Stagger Plants in rows. Backfill planting hole with soil mix while working each layer to eliminate voids.

When approximately 2/3 full, water thoroughly, then allow water to soak away. Place remaining backfill and dish surface around plant to hold water. Final grade should keep root ball slightly above surrounding grade, not to exceed 1". Water again until no more water is absorbed. Initial watering by irrigation system is not allowed.

**STAKING OF TREES:** Stake or guy all trees. Stakes shall be 2" X 2" (nom.) quality tree stakes with point. They shall be of Douglas Fir, clear and sturdy. Stake to be minimum 2/3 the height of the tree, not to exceed 8'-0". Drive stake firmly 1'-6" below the planting hole. Tree ties for deciduous trees shall be "Chainlock" (or better). For Evergreen trees use "Gro-Strait" Tree Ties (or a reinforced rubber hose and guy wires) with guy wires of a minimum 2 strand twisted 12 ga. wire. Staking and guying shall be loose enough to allow movement of tree while holding tree upright.

**MULCHING OF PLANTINGS:** Mulch planting areas with dark, aged, medium grind fir or hemlock bark (aged at least 6 months) to a depth of 2" in ground cover areas and 2 1/2" in shrub beds. Apply evenly, not higher than grade of plant as it came from the nursery, and rake to a smooth finish. Water thoroughly, then hose down planting area with fine spray to wash leaves of plants.

**FINE LAWN AREAS:** In fine lawn area apply Commercial Fertilizer Mix "B" at 4.5 lbs. Per 1,000 sq.ft. and rake into soil surface. Establish an even, fine textured seedbed meeting grades, surfaces and texture. Sow seed with a mechanical spreader at the uniform rates as noted below. Rake seed lightly to provide cover.

**SEED:** Blue tag grass seed conforming to applicable State laws. No noxious weed seeds. Submit Guaranteed analysis.  
**Fine Lawn Seed Mix:** To contain 50% Top Hat Perennial Ryegrass, 30% Derby Supreme Ryegrass, 20% Longfellow Chewings Fescue (Hobbs and Hopkins Pro-Time 303 Lawn Mix or as approved) Sow Seed at 5 lbs. / 1000 sq. ft.

**MAINTENANCE OF SEEDED AREAS:**  
**Fine Lawn Areas:** The lawn areas shall be maintained by watering, mowing, reseeding, and weeding for a minimum of 60 days after seeding. After 30 days, or after the second mowing, apply Commercial Fertilizer Mix "C" at 5 lbs. per 1,000 sq. ft. Mow and keep at 1 1/2" to 2" in height. Remove clippings and dispose of off site.

**GENERAL MAINTENANCE:** Protect and maintain work described in these specifications against all defects of materials and workmanship, through final acceptance. Replace plants not in normal healthy condition at the end of this period. Water, weed, cultivate, mulch, reset plants to proper grade or upright position, remove dead wood and do necessary standard maintenance operations. Irrigate when necessary to avoid drying out of plant materials, and to promote healthy growth.

**CLEAN-UP:** At completion of each division of work all extra material, supplies, equipment, etc., shall be removed from the site. All walks, paving, or other surfaces shall be swept clean, mulch areas shall have debris removed and any soil cleared from surface. All areas of the project shall be kept clean, orderly and complete.

MATCHLINE: SEE SHEET L2.0

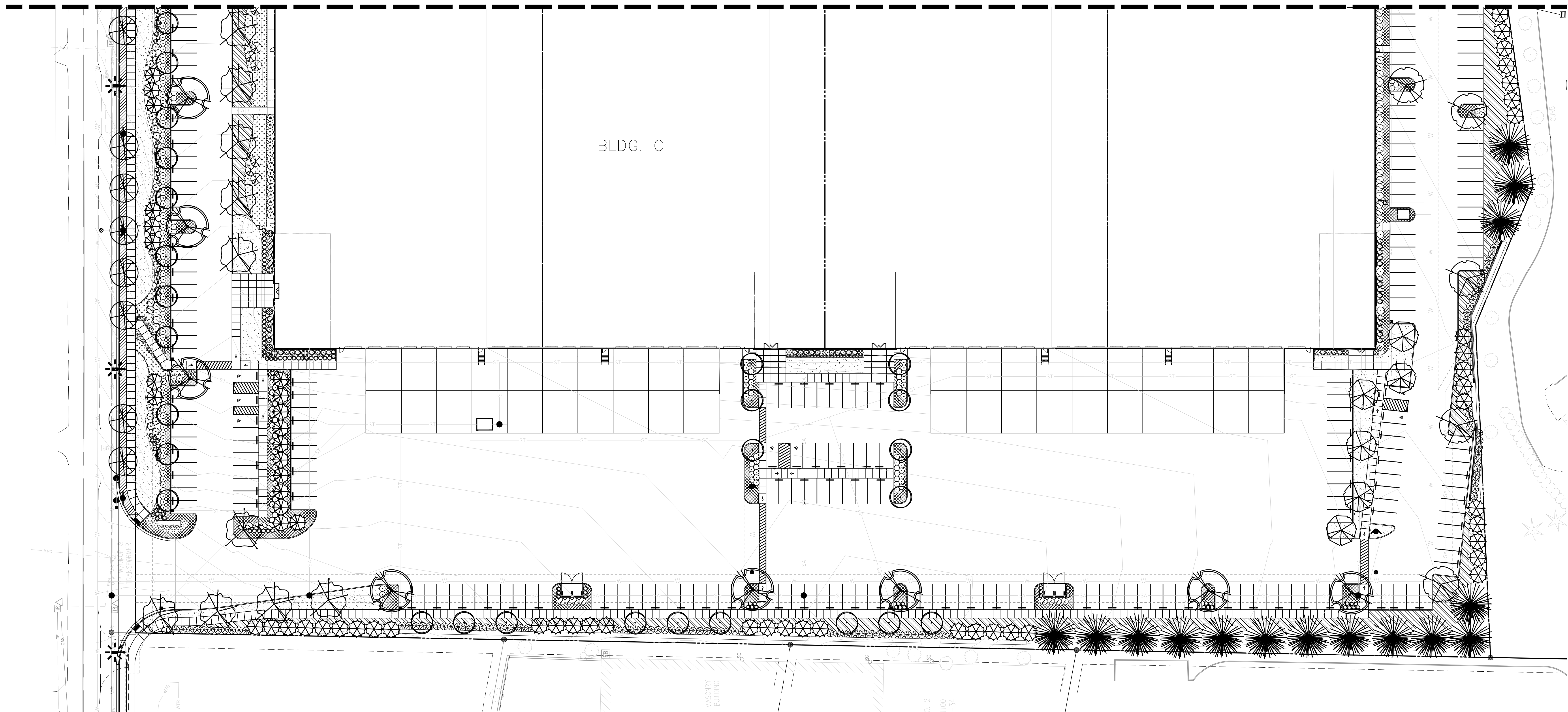

PLANTING PLAN 'B'

SCALE 1" = 30'-0"

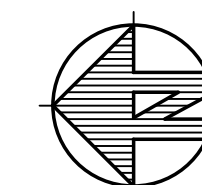

PROJECT NAME

**BAKER CENTER**

**BUILDING A**

**1ST AVENUE AND  
WALNUT  
CANBY, OR 97013**

REVISIONS

DATE	DESCRIPTION

DATE: MARCH, 2018

SCALE: NOTED

DRAWN: DM/EH

CHECKED: EH

LANDSCAPE PLAN



















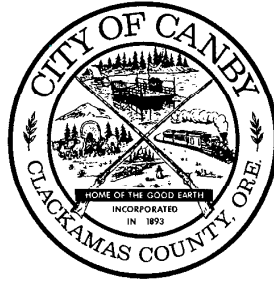

## **Pre-Application Meeting**

**Canby West  
July 9, 2019  
10:30 am**

### **Attended by:**

Doug Erkson, Canby Utility, 503-263-4331

Deniz Arac, TTC, 503-381-3891

Matt Downs, DirectLink, 503-341-4357

Greg Blefgen, VLMK, 503-539-0451

Daryll Hughes, Wastewater Treatment Plant, 503-266-0647

Bryan Brown, Planning, 503-266-0702

Hassan Ibrahim, Curran-McLeod Engineering, 503-684-3478

Kirk Olsen, TCC, 503-890-5172

Matt English, Canby Fire, 503-878-0187

Brian Dubal, VLMK, 503-222-4453

Jerry Nelzen, Public Works, 503-266-0759

***This document is for preliminary use only and is not a contractual document.***

### **VLMK ENGINEERING, Greg Blefgen**

- We are working with the Trammel Crow Company on the project just across the street from the Shakespeare project (Canby East) and Trammell Crow has tied up this property as well. We did have more of the property tied up, but now it has been scaled back a bit and we have done our due diligence on this property, we have done a complete survey and preliminary geotechnical investigations. We have a project associated with Canby East, which is going to include a reclamation pavement project along SE 1<sup>st</sup> Avenue and the Canby East project is taking the utilities and extending them and doing half street improvements up to SE 1<sup>st</sup> Avenue. The development we are showing right now is taking two parcels and creating on large parcel into three properties and we would hope to find a build to suit user we could get into one of these buildings, whether that happens before we decide to do a speculative development it has yet to be determined. The timing at this point is not defined and Kirk stated unlike the project across S Walnut Street to the east, this will be a speculative venture with no user identified as Greg mentioned there is a possibility we could come out of the ground with all three at once or one and hold the others for a particular user and again that is to be determined and it is something we are working on the business side. Generally, our business plan is to get these buildings through a large part of the entitlement and permitting process and if we have people say they are ready and this building we will build it for them. We do intend to take it through permitting.
- The building construction will be a concrete tilt-up, likely wood roof decks, steel joists, hybrid type of system could be a metal deck, and a five B construction occupancy could be either light manufacturing or warehouse, S-1 or F2 type of use.
- All buildings will be sprinkled.
- There is a significant change in the topography where we go from 165 to 143 a fair amount of 25 ft plus or minus grade change. We want to be as flexible as possible with the

partitioning and we want each of these buildings to stand alone and if we find a user first we want to have the utilities and everything ready for the building.

- It is our understanding we will extend a water line to connect into the water main line we just extended along SE 1<sup>st</sup> Avenue.
- The sanitary extension we are also anticipating would occur along SE 1<sup>st</sup> Avenue.
- We have power extensions on the east side of the right-of-right (ROW) being put in with the Canby East development and we have laid out street lights for our side of the street which we assume would go in with our development as well.
- The Larusso property has a small easement on our corner of the property that we believe is for a septic system and whether that easement is active or not or just an easement encumbrance across the land. We are illustrating a sanitary connection to serve this property if they cannot get served from S Walnut Street.

### **TRAMMELL CROW COMPANY, Kirk Olsen**

- The standalone nature subversive to say is what that means is each of the three buildings stands on its lot as Greg mentioned and can be under separate ownership and figuring out their frontage, shared stormwater agreements and we want them to be purchased by users, which is fairly prevalent down here. That said it is speculative that each building is designed to be multi-tenanted.

### **CURRAN-MCLEOD ENGINEERING, Hassan Ibrahim**

- On S Walnut Street you are going to mimic what you did on the other side of the half street improvement and also the same thing on SE 1<sup>st</sup> Avenue we are going to go to 50 ft wide curb to curb and you will build a 25 ft half street, which includes curbs, sidewalks, street lights and planter strip all the way down to S Hazeldell Way.
- The signal at Hazeldell is going out to bid at the end of this month and it is just food for thought. This signal will go in at Hazeldell Way and Sequoia Parkway and Greg said as part of the Canby East development we participated in that improvement costs and maybe you could speak about the connection to 99E and give us an update. Jerry said our city administrator is signing the final paperwork on the Green property as we speak and we have everyone on board to build the road through there. We will need to amend the Transportation System Plan (TSP) and go through the process with DKS Engineering and hopefully, in five years we will be close to getting started on building the road through there. Bryan said I do have the latest update for this project list and they are estimating the total at six million dollars to put the road through and they are indicating the projected expenditure in this fiscal year starting July 1<sup>st</sup> of \$1,300,000 to get a design. Greg asked if Canby East and West will be burdened with any of the costs and Bryan said I cannot answer that 100 percent, but I am not thinking so because what I think you will be burdened with is paying a transportation system development charge (SDC) otherwise it is adjacent improvements.
- Greg said we illustrated the sanitary sewer and the water offset from the centerline of the street. Primarily, hopefully, keep the road improvements we are doing now as part of that and are there any concerns with it being offset from the centerline. Hassan said it needs to be offset because ultimately the extension has to go through to connect to the highway and potentially serve all the property. When we get to that point, we need to make sure we have the depth to get to all the properties and we may have to pay for the extra to go a little deeper.

I want to make sure we understand each other because we want the sewer on the unimproved side and Jerry said we are improving that side. Greg asked if the sewer could be on their side of the road so we keep what we just built in place and we expand on to that and Jerry said where are you thinking of the placement. Greg said we are showing it on the edge of what we are paving right now, but we can switch the water so it is closer knowing that the water will be at a constant depth, but if the sanitary is going to have to dive deep which we know to serve other properties we want to minimize the impact of these improvements. Hassan said we do not know how deep we need to be, we are still working on the survey because it is a busy time of year for the surveyors and at some point, we will know the depth. Jerry said they are scheduled so it will be soon. Hassan said because we never extended the dry line to the pump station, the Larusso property and the property just down from them have no access to a gravity sewer. So we need an easement from you to serve those properties and Greg said if we do a public sewer main to here and Hassan said it has to go across the Larusso property to the next one down, but we just need the public sewer main to the property line and Jerry said that is the solution to serving those two properties. Hassan said the other option is to extend the dry line to the pump station and Jerry said what is easier and Hassan said it would be easier to have a public sewer main through here. Jerry asked if the sewer main getting to those properties would it be in a paved area and Greg said we are illustrating it in a paved area right now. Jerry stated for SE 1<sup>st</sup> Avenue they will have to do the full frontage sewer main extension. Bryan asked what size sewer line are you talking about and Hassan said there is a 12 inch sewer main at S Hazeldell Way and we would be asking for a 10 to a 12 inch line they would need to extend to S Walnut Street. Hassan said we would pay the difference for the upsize from an 8 inch.

- The private stormwater stays on site and for the public, you will put in some drywells and Greg said we planned the S Walnut Street for that extension.
- Jerry asked about the street trees and Greg said we planned for them. Jerry asked if they were going to follow the same street tree design under the power lines and Greg said yes.
- Greg asked is this property in front of the cemetery and the driveway tying into the walk I do not know and Kirk said with the utility pole, fire hydrant and Hassan said all the improvements are to the Larusso frontage. Kirk asked about driveway adjacent to one another and Hassan said on S Walnut Street is a local industrial street. Greg asked if there will be any county involvement and Hassan said there could be a possibility of some part on the intersection of SE 1<sup>st</sup> Avenue and S Walnut Street. Jerry said it would be good to include them and Bryan said yes.
- Jerry asked about moving the centerline over on SE 1<sup>st</sup> Avenue and Greg stated they will be doing the full 50 ft paved street width and the 17 ft ROW is going to 22 ft of pavement and we are continuing it down our frontage to get to the overall 50 ft width. Jerry said we are okay with the travel lane and the answer was yes. Jerry said it will also have a bike lane and the answer was yes and Jerry said we can do curb inlet basin on it. What are your thoughts on putting the drywells in the center of the roadway and Greg said we would like to keep everything closer to our side with the FDR project going on right now if we can. Jerry said he would like to see the placement of the drywells, sediment manholes and catch basins before I comment. I am working with Perlo on the drywells for the Shakespeare project and what I told them is we could do a GeoTech report on one and eliminate a bunch of them by connecting them. I will leave that option open again if we want to do fewer drywells by

connecting them and the result would be fewer drywells and it saves you money. Greg said we looked at them and the spacing was too far in Shakespeare, but it might make sense here because of the slopes and Jerry said we talk more on this.

- Will, there be sampling manholes for each building and will you be using the public sewer main going across your property and Greg said we intend to serve this building off the backline because it is right there and extended the sewer line going between the building A and to serve this parcel. Jerry asked if there was enough fall to run a public line down the middle to serve these buildings and how they would separate the building via the sampling manholes and Greg said we could connect the buildings to a sampling manhole and what is the spacing between manholes on public lines and Hassan said 400 ft. Greg said we can connect into the manhole here and we can also put a manhole at the juncture and serve both buildings. Daryll said it works best for us because we do not know who is coming in and Greg said because we do not know what is coming in and conservative play would be a sampling manhole on each on the private connections. Jerry said if you do that then everything going in that manhole would be private and you would run a 4 inch line into the manhole. It solves a lot of problems for us and separates us from you and when there is only a bathroom these big lines do not get the flow.
- Did NW Natural communicate with you on what they needed to get something done and Greg said I think they wanted to put in an 8 inch line up to here and a 6 inch coming to here this is what was communicated to us a couple of weeks ago. We would intend to install this within the PUE as we come up the street. The other factor is the PGE poles, like we are doing over here where PGE serves the properties to the north and we anticipate having to relocate their overhead lines and Jerry asked if it would become to Canby Utility and go underground. Greg said all of these properties are annexed and are still under PGE and Doug said it is just like the properties in front of Active Water Sports and it will stay the way it is. Greg said we would love to have it all underground, but it is the challenge we have right now.
- Jerry said you will need to locate all the water wells and make sure they are at the proper distance away from each other.
- Jerry said when I shot the sewer dry line over here it was 14 ft deep or close to that, I am giving you some rough numbers now and we are going to take the sewer towards Otto Road and Otto Road falls off in the other direction. Hassan said we will know more once the survey comes in and Greg said our concern with everything on this site dips down, so if we are serving a dipped down area it may need to have a pump station to serve it.
- Greg said we illustrated 50 ft driveway approaches as we did on Shakespeare and it will be primarily to serve the truck traffic areas and it certainly helps and we can provide you with the templates or whatever you need. Jerry said once the project starts and since we are in the city limits it should be okay. We will need to make sure the dust is down and you do not track anything on the roadways. The other thing was keeping the truck traffic on the truck routes. I am excited about this project starting.

**CITY OF CANBY, WASTEWATER TREATMENT PLANT, Daryll Hughes**

- You do not know who will be going into these building(s) and I have a few handouts that are required and if you can fill out the Environmental Survey the best you can since you do not know who is coming in and you can have 30 days to get it back to me.

- Once you are operating I will come out and inspect what type of businesses that will be there. Will you be renting/leasing to these businesses and the answer was right now they are set up for full building purchase to a user, but possibly a lease. Daryll said if you will let us know who will come in and what type of process they will do and if there is any generating of wastewater I would appreciate it.
- Will there be any floor drains in the buildings and the answer was they were not planning on installing floor drains. Daryll said the other big piece was the sampling manholes and it sounds like we have that situated and Greg said yes, we have options. Kirk said if these are split into two tenants with different exit lines, we will work through it with you.

#### **DIRECTLINK, Matt Downs**

- We will be going into the same trench line as the power and doing the same trench line feeding into the buildings.
- Greg asked if you will be doing any of the extensions up S Walnut and Deniz said we talked about it for the Shakespeare project and he is interested in getting a 4 inch in the trench. Matt said on this side of S Walnut Street we would like to get a 4 inch going north and also on SE 1<sup>st</sup> Avenue going east. My understanding is the communication room is on the NE corner and that is where we would be feeding the com/mechanical room with a flat drop.

#### **CANBY FIRE DEPARTMENT, Matt English**

- We have done the RSSI study for the radio signals strength and we have the new mobile radio repeater, which we have already dealt with for the Shakespeare project and it is working well.
- The FDC for these remotes are outside the collapse zone and a hydrant needs to be within 50 ft of those and if you want to put all three of them for that complex in one spot and label them with the different addresses it would work.
- As far as the building's addresses make sure they are 16 inch contrasting numbering/lettering at the top corner. Greg said visible from the street and do you have any preference on whether they are addressed off of S Walnut Street or SE 1<sup>st</sup> Avenue, I mean these buildings have more of a frontage off of S Walnut Street. Matt asked if they are addressed off of S Walnut Street and Greg said he did not know. Matt said when we do fire calls we go off of the addresses and Greg said as we are partitioning this building it would be addressed off of S Walnut Street and these buildings I do not know. It was asked if they preferred suite numbers or letters for the addressing or does each store front have its address and Matt said each building will have its physical address it will not be the same address with building A, B or C. Kirk said this could be 1, 2, 3 with suite A, B or C and Matt said it would be great to have those marked above and we would match our pre-fire plans with that also. Matt Downs said we record our services with 911 and they are geo-located and those addresses are what we base our 911 service recording. Greg said in the past we have done Knox suites and there will be a range of addressing is what I would anticipate.
- We would like to have the annunciator panel for the alarm to be in the main entry, but if you are going to have different suites that will not work out for identifying because you would not want to put in a panel in each different suites. Kirk said we will work with you to find out where the best solution to place the panel, possibly the riser room and Greg said we normally put it in the riser room and the way we have it laid out right now it certainly can



flex, but with the water line coming in at the corners of the buildings and we would not like to have the riser room in the front by the office areas. We have the riser rooms tucked back in the corners and your comment on the having the FDC available in one location is there any concerns Matt with us having a hydrants right outside these rooms whether they are shared and Matt said as long as the FDC is actually labeled with address number on it so they know which one to hook up to.

- We like to have the Knox box on the entry because the bigger the warehouses that are a standalone we like to have the Knox box and the annunciator panel at the front entry way so if we had to have a second panel from the riser area to there we know with the different suites it could be a myriad of how you could be annunciating each one of those that are different tenant spaces also.
- We would like to get a .pdf or the like from you for the building for our pre-fire plan. We use a software plan instead of drawing them. Greg asked what do you need on the .pdf and Matt said we need the shell and then we add-in the water shutoffs, main panels, etc.

### **CANBY UTILITY, Doug Erkson**

- On the east side of S Walnut Street, we have our electric system and are you going to feed these buildings from S Walnut Street or SE 1<sup>st</sup> Avenue. Greg said we anticipate doing a combination and for this building, we would like to keep the riser/electrical room in the corners and I would anticipate us coming into that corner of the building off of S Walnut Street. Doug asked about setting the transformer on the backside and Greg said on the side of the building where we have a landscaped area here and set the transformer within the parking or close to it. Doug said in the strip and I do not believe stubs are coming across the street and either we can come down the main corridor and maybe come in that way at least on the backside for either one of these buildings and the same thing on this one, come down the backside and feed this one. This one will be split up into three tenants and are you going to have individual transformers and Kirk said it will be split into four and the intent is to have a single transformer with the main panel that would have the split meter panels. Doug asked if they wanted them close or the furthest away from access in either direction. Greg said this building might be a little bit different and we might want to consider coming into this corner and that would be quite a long run and we know we need to get water back here and we may end up swapping the water to this side. Doug said if you come off S Walnut Street you can come straight down your parking lot and feed these buildings and do an extension to this building and just stay to the one side and only do one street crossing and you can keep it all on the property. You will still have to do the improvements on SE 1<sup>st</sup> Avenue to connect the S Hazeldell Way and S Walnut Street and Greg said we would probably come down here to serve both of these and then we would probably come in here to serve this building and Doug said if that is where you mechanical room is going to be it makes sense and then there would be no street crossing on this side. Greg said to coordinate the street crossing we work with you and Doug said of course and we do not have the loading information and when you have it send it to Gary he does our designs.
- We have already discussed extending the water main down SE 1<sup>st</sup> Avenue and I believe we discussed a 14 inch line and it will join up with what is already existing at S Hazeldell Way and S Walnut Street. Will you be serving them off of SE 1<sup>st</sup> Avenue and Greg said SE 1<sup>st</sup> Avenue for these two building and S Walnut for this building, which is another crossing and

Doug said that will be the long side on S Walnut Street. Greg said we are showing a public loop going through our site and is that a requirement, we know we are going to have different properties and have hydrants positioned throughout the area and Doug said you will also have your hydrants down the center and Greg said yes.

**CITY OF CANBY, PLANNING DEPARTMENT, Bryan Brown**

- The applications will be a Site and Design Review and because of the acreage you are doing the fee is the maximum, which is \$5,600.00. Are you thinking of doing all three buildings and potentially this yard through the Site and Design Review at the same time? If you do and it is all approved and then you can build it in whatever phases you want to and Greg said providing that flexibility makes sense and the question is if we get a big user here do we need to have these three properties. Bryan said that is what I was not certain about is if you were running a simultaneous partitioning creating three lots here and the fourth lot is the yard because it is a separate parcel. Greg said we are now showing three parcels and Bryan said he did not know if you were coming back when you know or do it on a separate application because you can get this approved as a single property through a Site and Design Review and then come back later and try to partition it and the idea is knowing you are thinking of partitioning is getting the utility service lines extended to them and separate. Greg said to give us the most flexibility we would include the partition with the Site and Design Review and if we have three properties and let us say we ended up with one user and then we would do a lot consolidation at that point and I think it makes sense to go ahead and get the partition included with the Site and Design Review and Bryan said it was my thought also.
- Because this is a speculative and we do not know if you will need a Conditional Use application for the 12 employees per acre and you might be able to help us by what you are marketing for and if you are relatively successful to the light industrial usage can you kind of estimate what you think what the employee count will be in those leased spaces and tell us whether it comes anywhere close to 12 employees per acre? My thoughts are probably not, but we do not know and Greg said he thought not, I would think we would want to include the Conditional Use application and get it approved, assuming we will have warehouses and at least we will not have to go back through the process. Bryan said again we are not anticipating any problem whatsoever with the Conditional Use because it is aspirational and we are still trying to get rid of this provision, but we cannot seem to get it through the council at this time. I think we have another proposal to lower it to 3 employees per acre so we do not have to keep doing Conditional Use permits. What we would be looking at a Minor Partition, Site and Design Review and Conditional Use permit and the cost for the Minor Partition is \$1,390.00, but you would get 25% off of that because of the multiple applications. The Conditional Use is \$2,080.00 and you would get 25% off of that also. It will take about a two month process to go through the plan use approvals and could potentially include a possible appeal and if that happens it could make it three months.
- I did an early estimate for the system development charges (SDC) and what you want to look at on this sheet is for your edification and visiting with us later. I put in the improvement costs you said in your narrative for the utilities and street installations as you can see the yellow highlights are optional numbers that can be changed, but I put in that number which generates what the fees will be, as the Engineering Plan Review fee. Discussion ensued on SDC fee basis. Hassan said I would like to reverse gears on the sewers and tell you on SE 1<sup>st</sup>

Avenue the sewer main does have to extend from Hazeldell Way to S Walnut Street, however we do have to pay for the upsizing and the extra depth we are asking them to provide and Greg said we would like to make sure this is understood along with the depth and Hassan said for example 20 ft. Bryan said if you lower the wastewater discharge SDC gallons and we are only collecting \$14,000.00 we are not going to give you any sewer SDC credit that is greater than the \$14,000.00 and Hassan said yes, that is clear. Bryan said you have to keep that in mind because you are not going to pay that much probably in wastewater SDC that we would give you enough to recoup the oversizing of the sewer line because you decided to develop and the city is not going to owe you money more than we would have otherwise collected. Hassan said the oversizing is not that expensive, like the digging, labor and all that because the difference would be the size of the pipe which would be \$4 to \$5 a foot. Greg said with the survey coming and it should let us plan on when/what we can do.

- There is one driveway at the SE corner and I think the Public Work Design Standards actually says on industrial roads you are supposed to have a 100 ft separation between the driveways and Greg asked about the local industrial classification and Bryan said on the local streets it is a 10 foot separation, but this is an industrial, which does not put it in the 10 foot range. Is there an existing driveway and Greg said yes. Hassan said it is a flat lot and belongs to the Larusso property and Bryan asked if it is house and the answer was it is a business now. Bryan said it may be something we will have to address through a design exception and we talked about that process and I think all the other driveways are okay.
- If your truck parking is visible from the street we would want to see some sort of landscaping buffer or screening and Greg asked if we placed the truck parking back here would that be a concern. Bryan said not necessarily, I mean we have tried it in other developments to have people do hedges or trees or partial screening, but we are more concerned about the view from S Walnut Street and SE 1<sup>st</sup> Avenue.
- Greg asked about the small pond and Hassan said Charlie Burden created it by damming it and Kirk said when I talked to John he said you can pay into the mitigation fund for the size of that one. Greg said it is a state level process and Bryan said it is the Division of State Lands and Hassan said he did not think it was documented wetlands, it is just manmade.



## MEETING NOTES

<i>Project:</i>	Baker Center	<i>Date:</i>	March 11, 2020
<i>Project Number:</i>	20180346	<i>Meeting Name:</i>	Neighborhood Meeting
<i>Project Address:</i>	Southeast 1st Avenue between S. Hazel Dell Way and S. Walnut Street	<i>Client:</i>	Trammell Crow Company
<i>Location:</i>	Canby Adult Center 1250 S. Ivy Street, Canby, OR		
<i>File Path:</i>	G:\ACAD2018\20180346\Permits\Neighborhood Meeting\01 Meeting Minutes 03-11-2020\Neighborhood Meeting Minutes.docx		

---

These minutes reflect our understanding of the topics discussed during the meeting.

### EXHIBITS DISPLAYED AT MEETING INCLUDED

- Masterplan of proposed development – Color print on 24x26 display board
- Rendering of Bldg C – Color print on 24x36 display board
- Aerial image of north half of Canby Pioneer IP – Color google image on 24x36 display board
- City of Canby Transportation Master Plan of area illustrating functional classification of streets - TSP Fig 7-1 Image mounted on 24x36 board

### THE FOLLOWING WAS DISCUSSED

Greg Blefgen opened the meeting and welcomed all attendees. He introduced himself as the project architect/engineer and provided a brief summary of the proposed development highlighting the following;

- The project site is located on parcel 300 which is bordered to the east by S Walnut St and to the north by SE 1<sup>st</sup> ave
- The project is being developed by The Trammell Crow Development company as a 'speculative light industrial' development that will be constructed in phases over an approximate 3-5yr period
- The development will include partitioning the 21 acre parcel to accommodate 3 buildings with a total footprint of approximately 334,000sf
- Building design will consist of concrete tilt up construction to provide warehouse space with building clear heights ranging from 26-32ft
- Street improvements will be provided along the SE 1<sup>st</sup> Ave and Walnut st. property frontages. ROW dedication and street Improvements will consist of;
  - 17ft of additional ROW dedication along SE 1<sup>st</sup> ave. with 25ft of paved half street, 6ft planter strip and 6ft sidewalk. Utility improvements in 1<sup>st</sup> ave will include water and sanitary main line extensions.

- 13ft of additional ROW dedication along S Walnut st. with 16ft of paved half street, 6ft planter strip and 6ft sidewalk.
- Stormwater for both half streets will be similar to the systems recently installed with the neighboring development which consists of curb inlets, sediment manholes and drywells.
- Franchise utilities to include power, natural gas and cable/communications will be installed within public utility easements at SE 1<sup>st</sup> ave.
- Relocation of the existing PGE power poles will be required along the SE 1<sup>st</sup> ave frontage
- To accommodate the 30ft of grade change across the 1<sup>st</sup> ave. frontage, the truck courts are located on the west sides of the building. To further mitigate the grade change, retaining walls are being provided along the east side of building C and the floor slab will slope 0.5% from south to north.
- Truck traffic will access the truck courts serving the site via the 2-50ft wide access drives at SE 1<sup>st</sup> ave. The primary auto access for buildings A & B will occur at the two 36ft driveways at S. Walnut st. Auto access for building C will share the truck entrances at SE 1<sup>st</sup> with some traffic utilizing the southernmost 'loop' road access drive at Walnut st.
- Storm water for the property will be retained on-site with runoff from the paved surfaces being treated prior to disposal with storm filter systems.

## **FEEDBACK / COMMENTS FROM ATTENDEES**

Andrew Sampson (TL 1300, 2112 SE 1<sup>st</sup> Ave)

- Andrew suggested that the attendees introduce themselves and note their property ownership. Greg started the introductions and all attendees introduced themselves in a clockwise manner. Andrew inquired about the truck access drive locations and noted that his property was located in close proximity to the proposed truck access drive near the west end of the development

Pat & Karen Imholt (TL 1202, 2150 SE 1<sup>st</sup> Ave)

- Pat said that he supported development on the property but was not pleased with the truck access location as his property was in near proximity to the western most truck drive at SE 1<sup>st</sup>.
- Pat asked Greg if he was aware of the zoning of the properties to the north. He shared that he had been told that the County was considering rezoning the properties to residential. Greg replied that it was his understanding that the properties were zoned rural residential farm forest and had not been annexed into the City and that he had not heard of any discussions regarding proposals to rezone the property. Pat was critical of industrial development in close proximity to residential zoned properties.
- Pat raised concern about the truck traffic and asked how much traffic the development would generate. Greg informed the group about the traffic study that was being coordinated by the City's traffic consultant and discussed the scoping requirements of the study. He pointed to the intersections in proximity of the development that would be reviewed and evaluated with the study. Pat asked Greg how much traffic would be generated by the development. Greg replied that the traffic study would evaluate the different light industrial uses and estimate the peak traffic demands utilizing the ITE manual. Greg suggested that the peak average weekday traffic counts could exceed 3 trips/thousand square feet of building...which could potentially exceed 1000trips/day with full build out.

- Greg discussed the truck traffic routes and the planned extension/connection to Hi-Way 99 and noted that truck traffic would be required to utilize SE 1<sup>st</sup> Ave & Hazel Nut or S Walnut St. to connect to Sequoia Parkway.
- Pat said that he was told that the City would not allow future development without the connection to Hi-Way 99 being completed. Greg responded that the City's traffic consultant did not anticipate that the traffic generated by this project would necessitate completion of the connection.
- Pat reiterated his concern about the traffic along SE 1<sup>st</sup> Ave and strongly suggested that we consider relocating the drives to Walnut st. Greg attempted to explain the logic of siting the buildings and truck courts to correlate with the topographic constraints. Pat became agitated with Greg's response and walked out of the meeting along with his wife and neighbor, Mr. Sampson.

Terry Tolls (T.N. Tolls Co., broker marketing property in the Canby IP)

- Terry attempted to mediate Mr. Imholts contentious comments about locating industrial developments adjacent to existing residentially zoned property by informing the group that the industrial park had been zoned industrial since the early 1970's.

Deniz Arac (Trammell Crow Co.)

- Deniz noted that the development will provide substantial improvements to the existing streets and that the system development fees required of the project would provide the City with significant monies that could be utilized towards the proposed Otto Rd. extension to Hi-Way 99.

Kathy Polley (Burden Family sibling and member of CCD Hazel Dell LLC)

- Ms. Polley voiced concern about the proposed storm water being retained on-site. She noted that storm water currently ponds at low areas of the site and specifically along localized areas of the south ROW of SE 1<sup>st</sup> ave. Greg noted that he was aware of the ponding water and that the near surface soils did not have good infiltration capabilities. He noted that the storm water would infiltration would be designed to occur at the dense gravel layer which occurs at 25-30ft below grade via drywells or storm chamber system installed at depth.

The meeting wrapped up around 6:45pm with several of the attendees having intermixed discussions.

END OF MINUTES

# CANBY WEST LIGHT INDUSTRIAL TRANSPORTATION IMPACT ANALYSIS

APRIL 2020

PREPARED FOR:

**CITY OF CANBY**

PREPARED BY **DKS ASSOCIATES**



EXPIRES: 12/31/20



720 SW WASHINGTON STREET, SUITE 500, PORTLAND, OR 97205 • 503.243.3500 • [DKSASSOCIATES.COM](http://DKSASSOCIATES.COM)

SHAPING A SMARTER TRANSPORTATION EXPERIENCE™

AN EMPLOYEE-OWNED COMPANY

# TABLE OF CONTENTS

- SECTION 1. INTRODUCTION..... 3
  - PROJECT AREA..... 3
  
- SECTION 2. EXISTING CONDITIONS..... 4
  - PEDESTRIAN AND BICYCLE FACILITIES ..... 4
  - TRANSIT ..... 4
  - MOTOR VEHICLE FACILITIES ..... 5
  - EXISTING TRAVEL CONDITIONS ..... 5
    - Daily Motor Vehicle Volumes..... 6
    - Intersection Operations..... 8
    - Safety Analysis ..... 10
  
- SECTION 3. ASSUMPTIONS AND METHODOLOGIES ..... 11
  - PROJECT DESCRIPTION ..... 11
  - SITE ACCESS..... 12
    - Sight Distance Review..... 12
    - Internal Sight Circulation..... 13
  - TRIP GENERATION ..... 13
  - TRIP DISTRIBUTION ..... 14
  - BACKGROUND TRAFFIC ..... 16
  - PLANNING HORIZONS ..... 16
  
- SECTION 4. FUTURE CONDITIONS..... 20
  - 2022 BACKGROUND CONDITIONS INTERSECTION OPERATIONS ..... 20
  - 2022 PROJECT CONDITIONS INTERSECTION OPERATIONS..... 21
    - S Walnut Road Extension..... 21
  - TRANSPORTATION SYSTEM CONTEXT ..... 24
  
- SECTION 5. RECOMMENDATIONS ..... 25
  - MOTOR VEHICLE IMPROVEMENTS..... 25
    - Site Frontage Improvements..... 25
    - Site Access Recommendations ..... 25
    - Sight Distance Recommendations ..... 26
  - PEDESTRIAN/BICYCLE IMPROVEMENTS ..... 26

## LIST OF FIGURES

FIGURE 1: STUDY AREA .....	3
FIGURE 2: EXISTING PEAK HOUR TRAFFIC VOLUMES .....	7
FIGURE 3: SITE PLAN.....	11
FIGURE 4: DISTRIBUTION OF SITE GENERATED TRIPS .....	15
FIGURE 5: 2022 BACKGROUND CONDITIONS TRAFFIC VOLUMES.....	17
FIGURE 6: 2022 PROJECT CONDITIONS TRAFFIC VOLUMES.....	18
FIGURE 7: 2022 PROJECT CONDITIONS WITH S WALNUT ROAD EXTENSION TRAFFIC VOLUMES	19

## LIST OF TABLES

TABLE 1: PROJECT AREA ROADWAY CHARACTERISTICS.....	5
TABLE 2: EXISTING 2019 STUDY INTERSECTION OPERATIONS.....	9
TABLE 3: CRASH DATA SUMMARY (2015 - 2017).....	10
TABLE 4: TRIP GENERATION FOR THE PROPOSED PROJECT.....	14
TABLE 5: BACKGROUND CONDITIONS INTERSECTION OPERATIONS.....	20
TABLE 6: 2022 PROJECT CONDITIONS INTERSECTION OPERATIONS (AM PEAK).....	22
TABLE 7: 2022 PROJECT CONDITIONS INTERSECTION OPERATIONS (PM PEAK).....	23
TABLE 8: VOLUME GROWTH COMPARISON ALONG SE 1 <sup>ST</sup> AVENUE .....	24



## SECTION 1. INTRODUCTION

The purpose of this transportation impact analysis is to identify potential transportation system needs triggered by the proposed Canby West Light Industrial Development located along SE 1st Avenue between SE Hazeldell Way and S. Walnut Road in Canby, Oregon. The proposed site is currently used for agricultural purposes and will consist of three buildings with approximately 334,800 square foot for warehouse and light manufacturing uses<sup>1</sup>. The site is zoned M1 – Light Industrial and is in the Industrial Area Overlay (I-O). Access to the site is proposed via two driveways to SE 1<sup>st</sup> Avenue and two driveways to S Walnut Road.

Included in the following sections is a documentation of existing transportation conditions, a summary of the assumptions and methodologies used to analyze future transportation conditions, a detail of traffic operating conditions and a summary of recommendations related to the proposed project.

### PROJECT AREA

The project site is generally bounded by SE 1<sup>st</sup> Avenue to the north, Sequoia Pkwy to the south, S Walnut Road to the east, and SE Hazeldell Way to the west. The following intersections were evaluated as study intersections (see Figure 1), with their intersection control listed:

- OR 99E / N Redwood Street/ Sequoia Parkway
- OR 99E / Territorial Road
- OR 99E / Haines Road
- Sequoia Parkway / SE Hazeldell Way
- Sequoia Parkway / S Walnut Road
- SE 1<sup>st</sup> Avenue / S Walnut Road
- SE 1<sup>st</sup> Avenue / S Mulino Road
- SE 1<sup>st</sup> Avenue / Haines Road / Bremer Road



FIGURE 1: STUDY AREA

<sup>1</sup> Canby West Light Industrial site plan, September 2019.



## SECTION 2. EXISTING CONDITIONS

This section provides documentation of existing transportation conditions in the project area, including an inventory of the existing transportation network, and an operational analysis and safety evaluation of the study intersections. Supporting details are provided in the appendix.

### PEDESTRIAN AND BICYCLE FACILITIES

---

An inventory of the existing pedestrian and bicycle facilities was conducted to determine the current location of sidewalks and bicycle lanes within the project area. Sidewalks are limited and are generally located along the frontages of new development on portions of Sequoia Parkway, S Walnut Road, and SE Hazeldell Way.

There is currently a striped bike lane along Sequoia Parkway and SE Hazeldell Way, however there are no other bike facilities within the project area.

Pedestrian and bicycle count data during the morning and evening peak periods was also collected at the study intersections<sup>2</sup>. The count data shows that most of the pedestrian activity observed occurred at the Sequoia Parkway / SE Hazeldell Way and the S Haines Road / S Bremer Road intersections (4 crossings during the p.m. peak period). Bicycle activity within the study area is minimal. The bicycle count data indicates that two movements occurred at the Sequoia Parkway / SE Hazeldell Way intersection in the p.m. peak period. Furthermore, one movement occurred at OR 99E / S Haines Road during the p.m. peak period and one movement occurred at the intersections of OR 99E / S Territorial Road and Sequoia Parkway / S Walnut Road in the a.m. peak period. No additional bicycle activity was recorded at the study intersections.

### TRANSIT

---

Transit service is provided in the vicinity of the project area by Canby Area Transit (CAT) via Route 99X to Oregon City and Woodburn. This route connects Canby to the Oregon City Transit Center where riders can transfer to several additional TriMet bus lines. The nearest bus stop to the project site is located approximately 0.5 miles to the southwest, near the OR 99E / Sequoia Parkway intersection.

CAT also provides general public Dial-A-Ride service for anyone traveling to or from destinations within the Canby Urban Growth Boundary (UGB). Service is provided between 8 a.m. and 6 p.m., Monday through Friday.

<sup>2</sup> Based on traffic counts conducted during October 2018.

## MOTOR VEHICLE FACILITIES

Characteristics of the key roadways in the project area are summarized in Table 1. Sequoia Parkway provides for higher capacity north-south motor vehicle movements through the study area. It is classified as a collector and maintains a continuous three-lane cross-section (i.e. one through lane in each direction with a center-turn lane) and connects OR 99E with S. Township Road. Both SE 1<sup>st</sup> Avenue and S Walnut Road are designated as local roadways in the TSP but are recommended to become collector roadways in the Walnut Street Extension TSP Amendment<sup>3</sup>.

TABLE 1: PROJECT AREA ROADWAY CHARACTERISTICS

ROADWAY	JURISDICTION	CLASSIFICATION*	NO. OF LANES	POSTED SPEED	SIDEWALKS	BIKE LANES
S MULINO ROAD	County	Collector	2	NP**	No	No
SE 1ST AVENUE	City/County	Local / Recommended as Collector****	2	45***	No	No
S WALNUT ROAD	City	Local / Recommended as Collector****	2	25	Intermittent	No
SE HAZELDELL WAY	City	Collector	3	25	Intermittent	Yes
SEQUOIA PARKWAY	City	Collector	3	25/35	Intermittent	Yes

\* Source: Canby Transportation System Plan. Adopted December 2010.

\*\* No posted speed

\*\*\* Based on 85th percentile travel speed along SE 1<sup>st</sup> Avenue

\*\*\*\* Recommended to become a collector roadway in the Walnut Street Extension TSP Amendment

## EXISTING TRAVEL CONDITIONS

To determine intersection operations, turn movement counts were conducted at study intersections during the weekday morning peak period (7 to 9 a.m.) and evening peak period (4 to 6 p.m.). The raw traffic count data is included in the Appendix. The existing peak period traffic volumes developed for the study intersections are displayed in Figure 2.

<sup>3</sup> Canby Walnut Street Extension TSP Amendment, DKS Associates, November 2019.

## DAILY MOTOR VEHICLE VOLUMES

Motor vehicle count data was collected along SE 1<sup>st</sup> Avenue near the proposed site<sup>4</sup>. The count data indicates that approximately 1,045 vehicles pass the proposed site along SE 1<sup>st</sup> Avenue during an average weekday. Approximately 50 percent of these vehicles travel eastbound and 50 percent travel westbound. The highest number of trips along SE 1<sup>st</sup> Avenue occurred during the p.m. peak hour, with 109 vehicles counted near the proposed site (53 eastbound and 56 westbound).

<sup>4</sup> Count data collected in February 2020 on SE 1st Avenue near the proposed site.

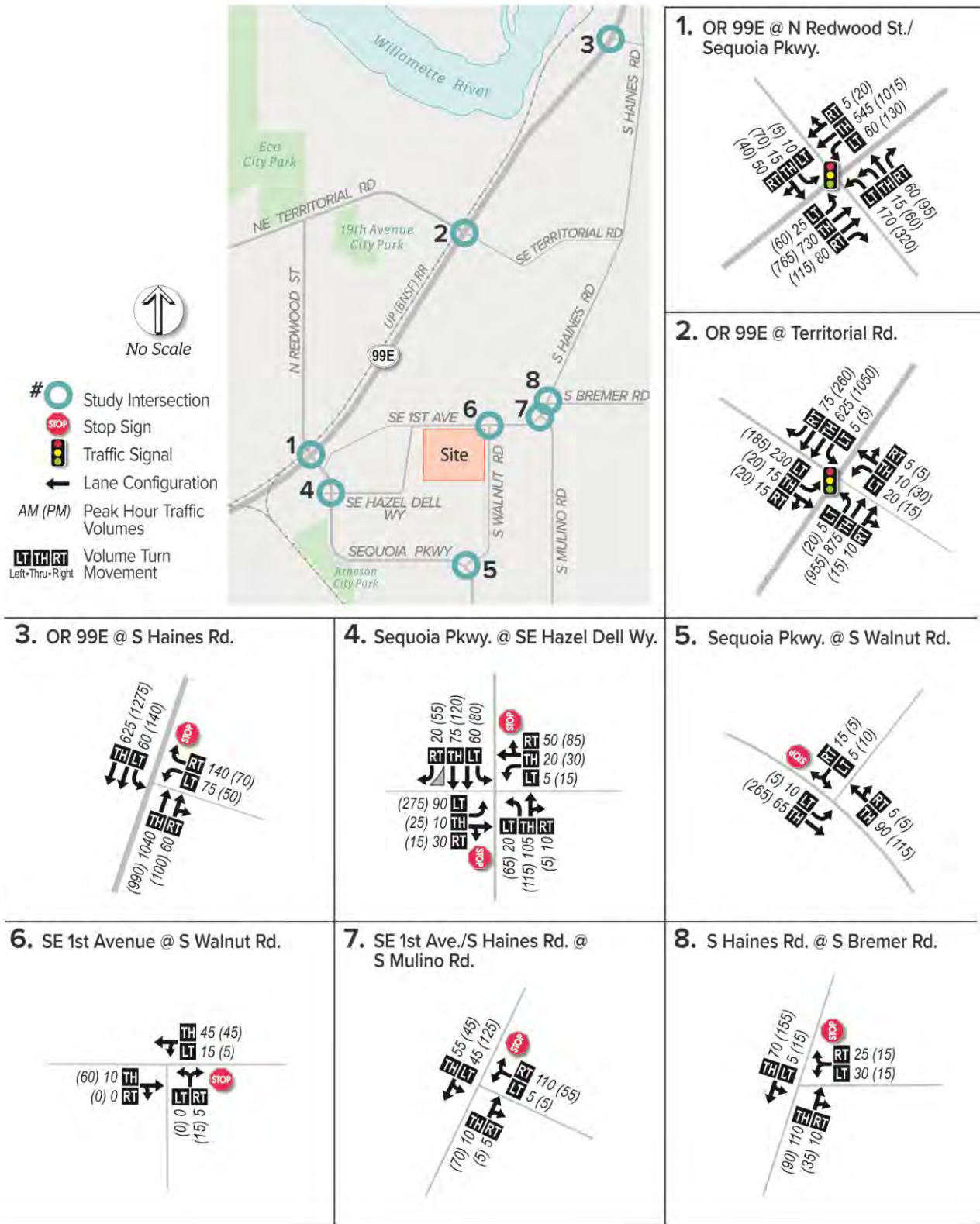

FIGURE 2: EXISTING PEAK HOUR TRAFFIC VOLUMES

## INTERSECTION OPERATIONS

This section discusses the existing conditions for motor vehicles at the study intersections, including an analysis of traffic operations.

### Intersection Performance Measures

Level of service (LOS) ratings and volume-to-capacity (v/c) ratios are two commonly used performance measures that provide a good picture of intersection operations. Agencies often incorporate these performance measures into their mobility standards. Descriptions are given below:

- Level of service (LOS): A **"report card" rating (A through F) based on the average** delay experienced by vehicles at the intersection. LOS A, B, and C indicate conditions where traffic moves without significant delays over periods of peak hours travel demand. LOS D and E are progressively worse operation conditions. LOS F represents conditions where average vehicle delay has become excessive and demand has exceeded capacity.
- Volume-to-capacity (v/c) ratio: A decimal representation (typically between 0.00 and 1.00) of the proportion of capacity that is being used at a turn movement, approach leg, or intersection. It is determined by dividing the peak hour traffic volume by the hourly capacity of a given intersection or movement. A lower ratio indicates smooth operations and minimal delays. As the ratio approaches 1.00, congestion increases, and performance is reduced. If the ratio is greater than 1.00, the turn movement, approach leg, or intersection is oversaturated and usually results in excessive queues and long delays.

### Jurisdictional Mobility Standards

The mobility standards for the study intersections vary according to the agency of jurisdiction for each roadway. Two of the study intersections are under City jurisdiction (Sequoia Parkway / SE Hazel Dell Way and Sequoia Parkway / S. Walnut Road), three are under ODOT jurisdiction (OR 99E / N Redwood Street / Sequoia Parkway, OR 99E / Territorial Road and OR 99E / Haines Road) and the remaining study intersections along SE 1st Avenue are under the jurisdiction of Clackamas County.

ODOT requires a volume to capacity ratio of 0.85 or less, Clackamas County requires a volume to capacity ratio of 0.95 or less<sup>5</sup>, and the City of Canby operating standards require that a level of service "E" or better and a volume to capacity ratio of 0.90 or less be maintained for intersections with stop control on the minor approach<sup>6</sup>.

### Existing Operating Conditions

Motor vehicle conditions were evaluated during the peak hours at the study intersections (see Table 2) using the 2000 Highway Capacity Manual (HCM) methodology for signalized intersections

<sup>5</sup> Clackamas County Comprehensive Plan, Chapter 5. Retrieved February 2020.

<sup>6</sup> Canby Transportation System Plan, Goal 7, Policy d, December 2010. Retrieved February 2020.

and the 2010 HCM methodology for unsignalized intersections. Two study intersections do not currently meet the mobility standards, including the Sequoia Parkway / SE Hazeldell Way and OR 99E / Haines Road intersections. At the Sequoia Parkway / SE Hazeldell Way intersection, there is a heavy eastbound left turn movement exiting the shopping center during the p.m. peak that experiences a high level of delay due to the conflicting traffic flows on the northbound and southbound approaches. However, this intersection is currently being improved with a traffic signal that will mitigate this issue.

At the OR 99E / Haines Road intersection, the left turn from Haines Road experiences moderate delay due to the high volume of traffic on the northbound and southbound OR 99E approaches. The analysis indicates that the v/c is greater than 1.0. However, since existing volumes were measured in the field conditions, the actual volume cannot exceed capacity and the conditions are overstated. Potential causes for this phenomenon may include that stopped vehicles are accepting shorter gaps, or the arrival patterns of traffic on OR 99E (due to the traffic signal at Territorial Road or the single approach lane on OR 99E to the north) are metered or platooned.

TABLE 2: EXISTING 2019 STUDY INTERSECTION OPERATIONS

INTERSECTION	TRAFFIC CONTROL	JURISDICTION	MOBILITY STANDARD	AM PEAK			PM PEAK		
				DELAY	LOS	V/C	DELAY	LOS	V/C
SE 1 <sup>ST</sup> AVENUE / HAINES ROAD / BREMER ROAD	TWSC	County	0.95 V/C	9.8	A/A	0.08	10.0	A/B	0.11
SE 1 <sup>ST</sup> AVENUE / S MULINO ROAD	TWSC	County	0.95 V/C	8.9	A/A	0.13	9.3	A/A	0.13
SE 1 <sup>ST</sup> AVENUE / S WALNUT ROAD	TWSC	County	0.95 V/C	8.7	A/A	0.04	8.8	A/A	0.03
SEQUOIA PARKWAY / S WALNUT ROAD	TWSC	City	LOS E, 0.90 V/C	9.3	A/A	0.03	10.4	A/B	0.03
SEQUOIA PARKWAY / SE HAZELDELL WAY	TWSC	City	LOS E, 0.90 V/C	15.3	A/C	0.23	76.4	A/F	0.95
OR 99E / HAINES ROAD	TWSC	ODOT	0.85 V/C	>300	B/F	1.38*	>300	B/F	1.37*
OR 99E / TERRITORIAL ROAD	Signal	ODOT	0.85 V/C	16.8	B	0.66	14.1	B	0.63
OR 99E / N REDWOOD STREET / SEQUOIA PARKWAY	Signal	ODOT	0.85 V/C	17.2	B	0.50	26.7	C	0.75

BOLD values indicate performance measures failing to meet adopted mobility targets.

\* Since existing volumes were measured in the field conditions, the actual volume cannot exceed capacity and the conditions are overstated. See narrative preceding Table 2.

## SAFETY ANALYSIS

The most recent three years of available collision data (2015 – 2017) for the study area was obtained from Oregon Department of Transportation (ODOT) and used to evaluate the collision history<sup>7</sup>. There were 28 crashes recorded at the study intersections over the three-year period, with the most crashes occurring at the OR 99E / N Redwood St / Sequoia Parkway intersection.

Crash rates at study intersections were calculated to identify problem areas in need of mitigation. The total number of crashes experienced at an intersection is typically proportional to the number of vehicles entering it, therefore, a crash rate describing the frequency of crashes per million entering vehicles (MEV) is used to determine if the number of crashes should be considered high. Using this technique, a collision rate of 1.0 MEV or greater is commonly used to identify when collision occurrences are higher than average and should be further evaluated. As shown in Table 3, crash rates calculated at all study intersections are well below this threshold, indicating the frequency of collisions is typical for the volume of traffic served.

TABLE 3: CRASH DATA SUMMARY (2015 - 2017)

INTERSECTION	TOTAL CRASHES	CRASH TYPE			CRASH SEVERITY			COLLISION RATE
		ANGLE OR TURN	REAR END	FIXED OBJECT	PDO*	MINOR INJURY	MAJOR INJURY	
SE 1 <sup>ST</sup> AVENUE / HAINES ROAD / BREMER ROAD	0	0	0	0	0	0	0	0
SE 1 <sup>ST</sup> AVENUE / S MULINO ROAD	0	0	0	0	0	0	0	0
SE 1 <sup>ST</sup> AVENUE / S WALNUT ROAD	0	0	0	0	0	0	0	0
SEQUOIA PARKWAY / S WALNUT ROAD	0	0	0	0	0	0	0	0
SEQUOIA PARKWAY / SE HAZELDELL WAY	3	3	0	0	2	1	0	0.55
OR 99E / HAINES ROAD	9	7	1	1	1	8	0	0.33
OR 99E / TERRITORIAL ROAD	5	3	2	0	2	3	0	0.18
OR 99E / N REDWOOD STREET / SEQUOIA PARKWAY	11	5	5	1	3	8	0	0.40

\*PDO = Property Damage Only

<sup>7</sup> ODOT reported collisions for January 1, 2015 through December 31, 2017.



### SECTION 3. ASSUMPTIONS AND METHODOLOGIES

This section outlines key assumptions and methodologies that were used to analyze future conditions and identify any potential impacts at study intersections. Areas of interest covered in this section are trip generation, trip distribution and background traffic growth.

#### PROJECT DESCRIPTION

The proposed project will consist of three buildings with approximately 334,800 square feet for warehouse and light manufacturing uses. The proposed site is located south of SE 1<sup>st</sup> Avenue, between SE Hazeldell Way and S Walnut Road and is currently used for agricultural purposes. The site plan can be seen in Figure 3.

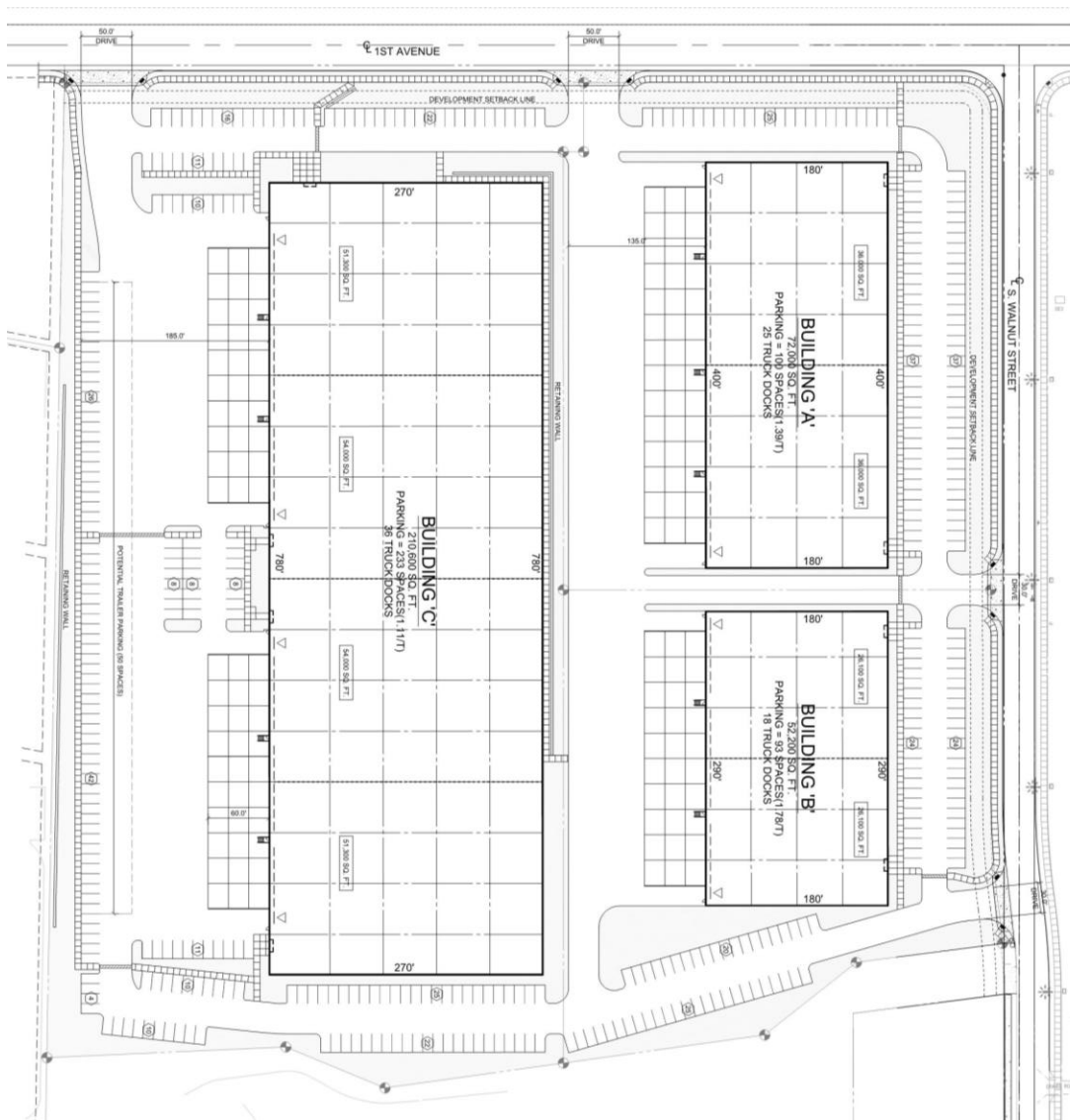

FIGURE 3: SITE PLAN

## SITE ACCESS

---

Access to the site is proposed via four driveways, two along S Walnut Road and two along SE 1<sup>st</sup> Avenue. Both SE 1<sup>st</sup> Avenue and S Walnut Road are classified as local streets in the TSP but are recommended to become collector roadways in the Walnut Street Extension TSP Amendment. The minimum spacing between accesses on the same side of a collector in the Industrial Overlay Zone is 200 feet<sup>8</sup>. The proposed driveways to SE 1<sup>st</sup> Avenue would be approximately 250 feet east and 400 feet west of the nearest roadways, and spaced approximately 400 from each other, complying with the spacing standard for a collector roadway. The proposed northern driveway to S Walnut Road will be approximately 500 feet south of the nearest roadway and spaced approximately 300 from the proposed southern driveway to S Walnut Road, complying with the spacing standard for a collector roadway. However, the proposed southern driveway to S Walnut Road would be located near the south property line, approximately 50 feet north of an existing driveway. Although the proposed driveway would be located 150 feet closer than the 200-foot collector spacing standard, no operational or safety issues are anticipated due to the low number of vehicles using the existing driveway that serves a light industrial use. The proposed driveway also meets the 10-foot spacing standard for the existing local street designation<sup>9</sup>, therefore no deviation to the Code will be required. However, the applicant is encouraged to work with the property owner to the south to consolidate the two driveways.

## SIGHT DISTANCE REVIEW

The sight triangle at intersections should be clear of objects (large signs, landscaping, parked cars, etc.) that could potentially limit vehicle sight distance. In addition, all proposed accesses should meet AASHTO sight distance requirements as measured from 15 feet back from the edge of pavement<sup>10</sup>.

The proposed accesses to SE 1<sup>st</sup> Avenue would require a minimum of 555 feet of sight distance based on an assumed 50-mph design speed. Preliminary sight distance evaluation from the accesses indicate that the proposed connections would be expected to provide sight distance of at least 600-feet looking to the west and at least 800-feet of sight distance looking to the east. The proposed accesses to S Walnut Road would require a minimum of 335-feet of sight distance based on a 30-mph design speed. Preliminary sight distance evaluation from the accesses indicate that the proposed connections would be expected to provide sight distance to SE 1<sup>st</sup> Avenue looking to the north and at least 600-feet of sight distance looking to the south.

<sup>8</sup> Canby Municipal Code 16.35.050.F. Retrieved February 2020.

<sup>9</sup> Canby Municipal Code 16.46.030. Retrieved February 2020.

<sup>10</sup> AASHTO – *Geometric Design of Highways and Streets, 6<sup>th</sup> edition, 2011.*

Prior to occupancy, sight distance at all access points will need to be verified, documented, and stamped by a registered professional Civil or Traffic Engineer licensed in the State of Oregon.

#### INTERNAL SIGHT CIRCULATION

Access to the site is proposed via two driveways to SE 1<sup>st</sup> Avenue and two driveways to S Walnut Road. Parking will be located on the outer perimeter of the buildings. Vehicles will primarily enter the site through the S Walnut Street driveways to access this parking. Trucks will access the project site through the SE 1<sup>st</sup> Avenue driveways, with the site designed to allow full circulation around the buildings to the loading docks located on the west side of the buildings. Both driveways on SE 1<sup>st</sup> Avenue are shown with 50-foot widths on the site plan to accommodate truck maneuvers while the two driveways on S Walnut Street are shown with 30-foot widths to accommodate passenger cars.

The proposed site also includes a sidewalk connection from both SE 1<sup>st</sup> Avenue and S Walnut Street to the building entrances, and sidewalks connecting the parking lots to the buildings. Until parcels surrounding this site develop, the frontage improvements along SE 1<sup>st</sup> Avenue and S Walnut Street will not connect to other nearby facilities. The proposed on-site pedestrian facilities and their connection to surrounding facilities appear to be adequate.

#### TRIP GENERATION

---

Trip generation is the method used to estimate the number of vehicles that are added to the surrounding roadway network as a result of proposed project. The trip generation was estimated using similar land uses as reported by the Institute of Transportation Engineers (ITE)<sup>11</sup>. The trip generation was conducted for the a.m. and p.m. peak hours using the Manufacturing (ITE Code 140) and Warehousing (ITE Code 150) land uses.

Table 4 summarizes the expected trip generation for the proposed project. As shown, the proposed site is expected to generate approximately 132 (101 in, 31 out) a.m. peak hour trips, 144 (44 in, 100 out) p.m. peak hour trips, and 949 daily trips. This includes 8 truck trips during the a.m. peak hour, 10 truck trips during the p.m. peak hour, and 179 truck trips in a day.

<sup>11</sup> *Trip Generation Manual*, Institute of Transportation Engineers, 10<sup>th</sup> Edition.



TABLE 4: TRIP GENERATION FOR THE PROPOSED PROJECT

LAND USE (SIZE)	AM PEAK			PM PEAK			DAILY TRIPS
	IN	OUT	TOTAL	IN	OUT	TOTAL	
MANUFACTURING - ITE CODE 140 (167,400 SQ. FT.)							
LIGHT VEHICLES	77	22	99	33	74	107	579
TRUCKS	3	2	5	2	3	5	79
TOTAL VEHICLES (LIGHT VEHICLES + TRUCKS)	80	24	104	35	77	112	658
WAREHOUSING - ITE CODE 150 (167,400 SQ. FT.)							
LIGHT VEHICLES	20	5	25	6	21	27	191
TRUCKS	1	2	3	3	2	5	100
TOTAL VEHICLES (LIGHT VEHICLES + TRUCKS)	21	7	28	9	23	32	291
TOTAL PROJECT LIGHT VEHICLES	97	27	124	39	95	134	770
TOTAL PROJECT TRUCKS	4	4	8	5	5	10	179
TOTAL PROJECT VEHICLES (LIGHT VEHICLES + TRUCKS)	101	31	132	44	100	144	949

### TRIP DISTRIBUTION

Trip distribution involves estimating how project generated traffic will leave and arrive at the proposed site. The trip distribution for the proposed project was estimated based on the City of Canby travel demand model<sup>12</sup>. It is estimated that 45 percent of the trips will originate from the southwest on OR 99E, 25 percent from the south on Sequoia Parkway, 15 percent from the east via S Haines Road or S Mulino Road, 10 percent from the north on N Redwood Street, and five percent from the northeast on OR 99E. It is estimated that 35 percent of the trips will leave the project site to destinations to the southwest on OR 99E, 30 percent to the east via S Haines Road or S Mulino Road, 20 percent to the south on Sequoia Parkway, 10 percent to the north on N Redwood Street, and five percent to the northeast along OR 99E. The assumed trip distribution for the proposed project can be seen in Figure 4.

<sup>12</sup> City of Canby Travel Forecast Tool, select zone model run for Traffic Analysis Zone 162.

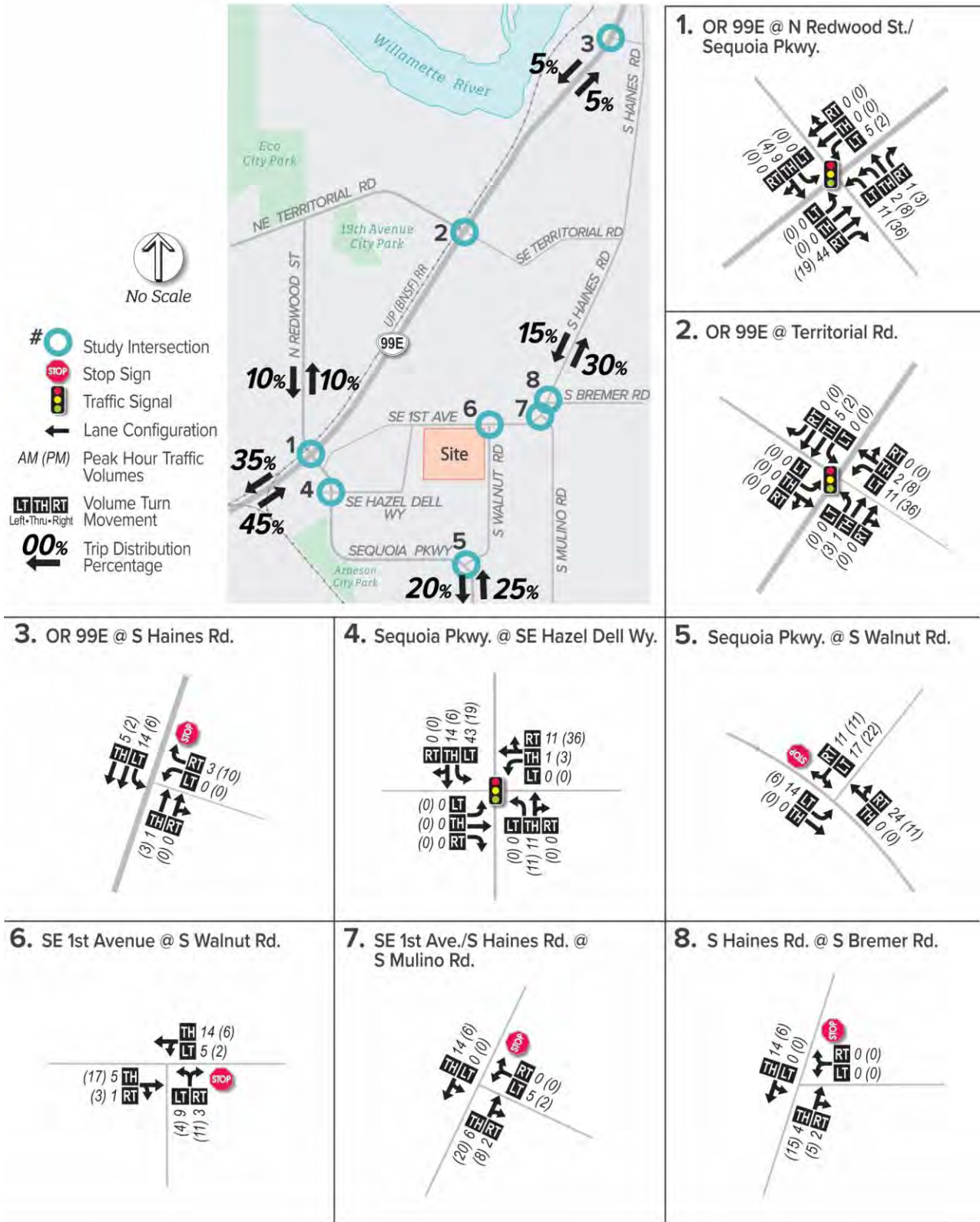

FIGURE 4: DISTRIBUTION OF SITE GENERATED TRIPS

## BACKGROUND TRAFFIC

---

In addition to the trips generated from the proposed project, trips from nearby approved but unconstructed developments were added as background traffic. Trips added as background traffic included those from the following developments:

1. Alpha Scents: 7,500 square foot corporate headquarters building including warehouse/ shipping area
2. Canby Active Water Sports: 25,000 square foot building including boat sales, display, and warehousing plus 35,000 square foot outdoor display area
3. BBC Steel Expansion: 31,050 square foot building including storage, office, and manufacturing space
4. Project Shakespeare: 514,500 square foot warehouse, which includes supporting office space

## PLANNING HORIZONS

---

The planning horizon year selected for analysis is 2022, which represents the expected year of build-out and occupancy for the proposed project. Two scenarios were evaluated to allow for the identification of capacity constraints associated with proposed project, including:

- 2022 Background Conditions – Existing traffic volumes plus background traffic growth.
- 2022 Project Conditions – Existing traffic volumes plus background traffic growth, with the added traffic associated with the proposed Canby West Industrial Site.

An additional sensitivity option was tested for the 2022 Project Conditions Scenario that assumed the planned extension of S Walnut Road between SE 1<sup>st</sup> Avenue and OR 99E would be completed (Figure 7).

All future scenarios include the installation of the currently under construction traffic signal at the Sequoia Parkway/SE Hazeldell Way intersection.

Figures 5 and 6 summarize the traffic volumes for the a.m. and p.m. peak hours at study intersections.



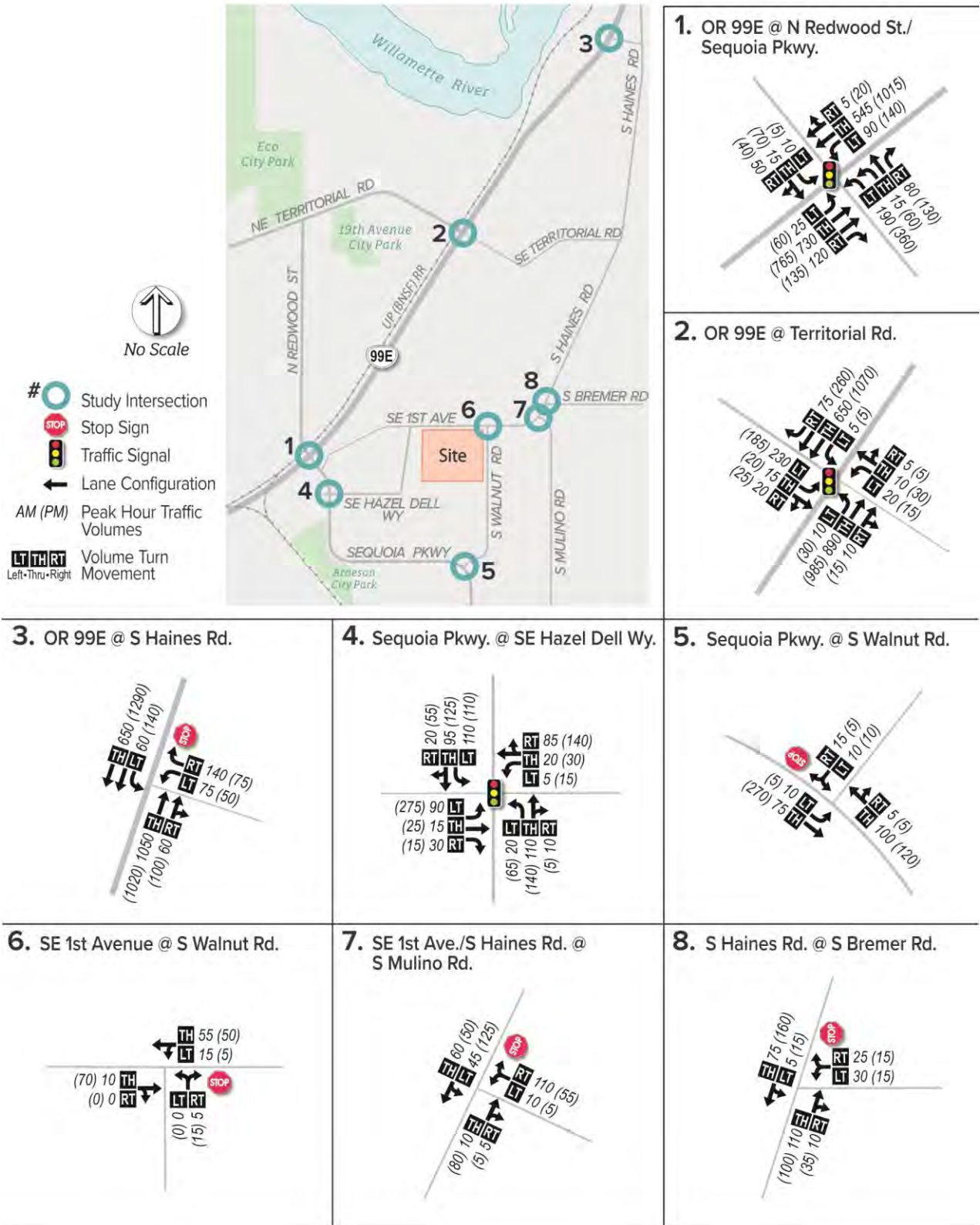

FIGURE 5: 2022 BACKGROUND CONDITIONS TRAFFIC VOLUMES

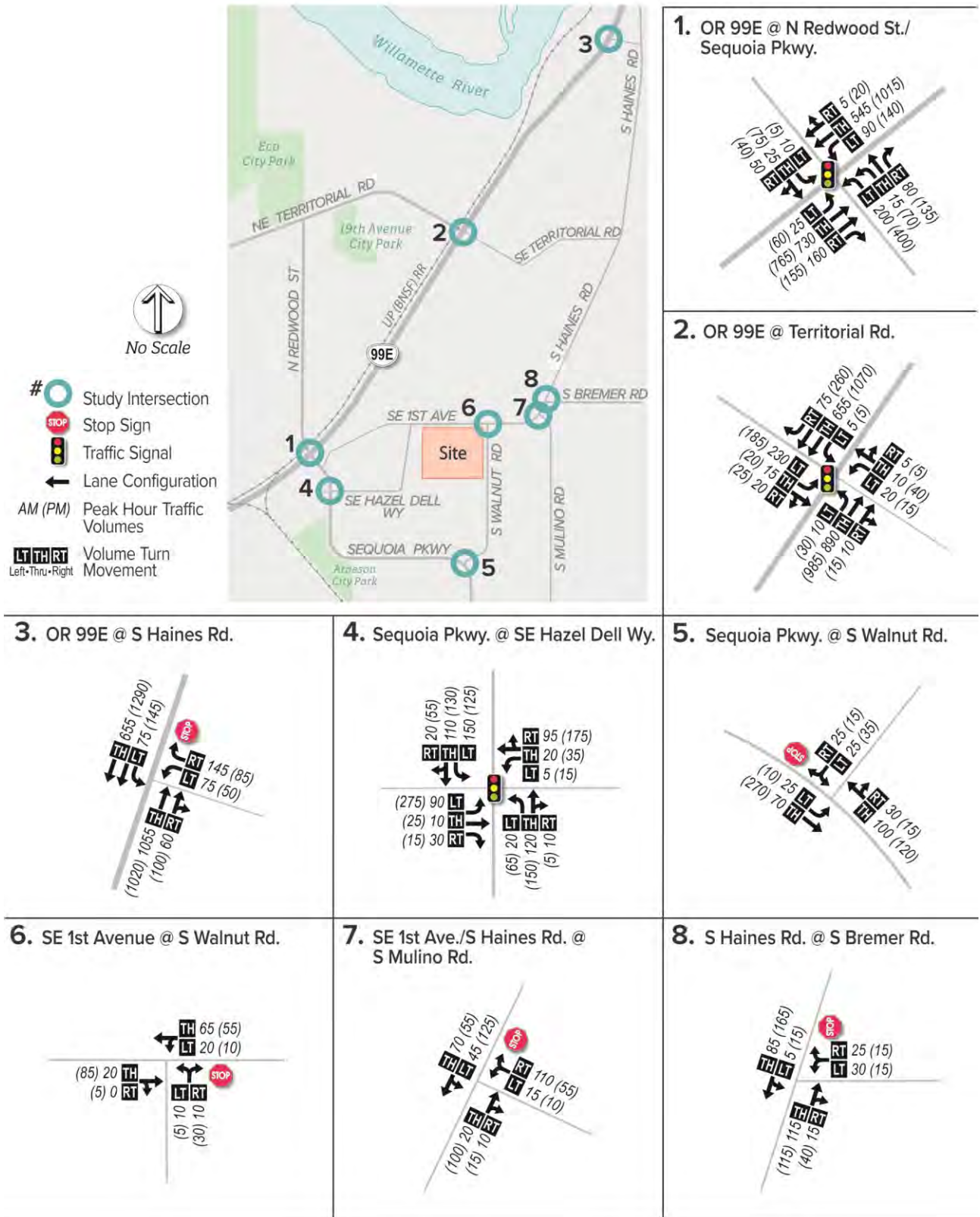

FIGURE 6: 2022 PROJECT CONDITIONS TRAFFIC VOLUMES

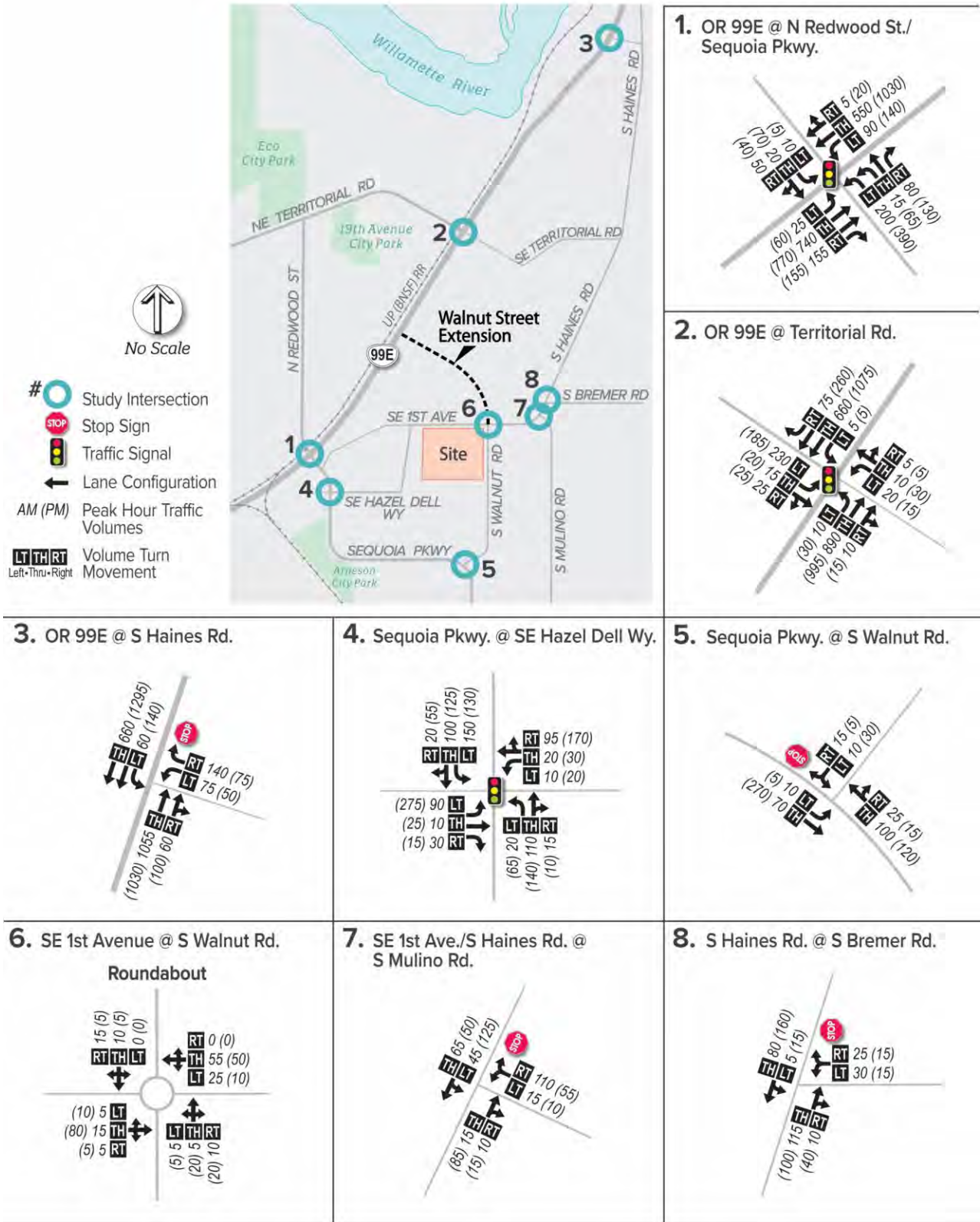

FIGURE 7: 2022 PROJECT CONDITIONS WITH S WALNUT ROAD EXTENSION TRAFFIC VOLUMES



## SECTION 4. FUTURE CONDITIONS

The following section summarizes the peak hour transportation operating conditions for the planning horizon year of 2022. Future traffic operating conditions were analyzed at the study intersections to determine if the transportation network can support traffic generated by the proposed project. If intersection mobility standards are not met, then mitigations may be necessary to improve network performance.

### 2022 BACKGROUND CONDITIONS INTERSECTION OPERATIONS

Table 5 shows the future 2022 intersection operations at study intersections, without the proposed project. As shown, no additional intersections fail to meet the mobility standards when compared to the existing conditions. The OR 99E / Haines Road intersection does not meet the mobility target under existing conditions and would experience increased delay with added background traffic. The intersection of Sequoia Parkway / SE Hazeldell Way is currently being improved with a traffic signal and no longer exceeds the mobility target with the improvement. Detailed intersection operations calculation worksheets are included in the Appendix.

TABLE 5: BACKGROUND CONDITIONS INTERSECTION OPERATIONS

INTERSECTION	TRAFFIC CONTROL	JURISDICTION	MOBILITY STANDARD	AM PEAK			PM PEAK		
				DELAY	LOS	V/C	DELAY	LOS	V/C
SE 1 <sup>ST</sup> AVENUE / HAINES ROAD / BREMER ROAD	TWSC	County	0.95 V/C	9.8	A/A	0.08	10.1	A/A	0.12
SE 1 <sup>ST</sup> AVENUE / S MULINO ROAD	TWSC	County	0.95 V/C	9.0	A/A	0.14	9.3	A/A	0.13
SE 1 <sup>ST</sup> AVENUE / S WALNUT ROAD	TWSC	County	0.95 V/C	8.7	A/A	0.05	8.8	A/A	0.04
SEQUOIA PARKWAY / S WALNUT ROAD	TWSC	City	LOS E, 0.90 V/C	9.6	A/A	0.04	10.4	A/B	0.03
SEQUOIA PARKWAY / SE HAZELDELL WAY	Signal**	City	LOS D, 0.85 V/C	19.0	B	0.35	24.1	C	0.49
OR 99E / HAINES ROAD	TWSC	ODOT	0.85 V/C	>300	B/F	1.43*	>300	B/F	1.49*
OR 99E / TERRITORIAL ROAD	Signal	ODOT	0.85 V/C	17.1	B	0.67	14.8	B	0.63
OR 99E / N REDWOOD STREET / SEQUOIA PARKWAY	Signal	ODOT	0.85 V/C	18.5	B	0.54	29.2	C	0.77

\* See narrative preceding Table 2 for note regarding v/c > 1.0. Conditions are overstated, and actual v/c is lower than reported.

\*\* The intersection of Sequoia Parkway/SE Hazeldell Way is assumed to be a signal in the future.

BOLD values indicate performance measures failing to meet adopted mobility targets.

## 2022 PROJECT CONDITIONS INTERSECTION OPERATIONS

---

The 2022 project conditions peak hour operations at study intersection are shown in Table 6 and Table 7. As shown, the added traffic associated with the proposed project is expected to have little impact on traffic operations when compared to the background conditions without the project (see Table 5 earlier in this document). No additional intersections fail to meet the mobility standards when compared to the 2022 Background conditions.

### S WALNUT ROAD EXTENSION

The planned extension of the S Walnut Road from SE 1<sup>st</sup> Avenue to OR 99E will not be completed concurrent with the proposed project. The project generated traffic in the 2022 Project Conditions scenario is assumed to route to OR 99E via Sequoia Parkway and Haines Road from the project driveways. Therefore, to ensure the growth can be accommodated, the future volumes and study intersection operations under the 2022 Project Conditions with the S Walnut Road extension were reviewed.

As shown in Table 6 and Table 7, the re-routed traffic associated with the planned extension of S Walnut Road to OR 99E is expected to have little impact on intersection operations when compared to the scenario without the segment.

TABLE 6: 2022 PROJECT CONDITIONS INTERSECTION OPERATIONS (AM PEAK)

INTERSECTION	TRAFFIC CONTROL	JURISDICTION	MOBILITY STANDARD	2022 PROJECT CONDITIONS (WITHOUT S WALNUT EXTENSION TO OR 99E)			2022 PROJECT CONDITIONS (WITH S WALNUT EXTENSION TO OR 99E)		
				DELAY	LOS	V/C	DELAY	LOS	V/C
SE 1 <sup>ST</sup> AVENUE / HAINES ROAD / BREMER ROAD	TWSC	County	0.95 V/C	9.9	A/A	0.08	9.8	A/A	0.08
SE 1 <sup>ST</sup> AVENUE / S MULINO ROAD	TWSC	County	0.95 V/C	9.2	A/A	0.15	9.2	A/A	0.15
SE 1 <sup>ST</sup> AVENUE / S WALNUT ROAD	TWSC / Roundabout ***	County	0.95 V/C	9.1	A/A	0.06	4.6	A	0.08
SEQUOIA PARKWAY / S WALNUT ROAD	TWSC	City	LOS E, 0.90 V/C	10.0	A/B	0.07	9.6	A/A	0.04
SEQUOIA PARKWAY / SE HAZELDELL WAY	Signal**	City	LOS D, 0.85 V/C	19.9	B	0.40	20.0	C	0.40
OR 99E / HAINES ROAD	TWSC	ODOT	0.85 V/C	>200	B/F	1.59*	>200	B/F	1.45*
OR 99E / TERRITORIAL ROAD	Signal	ODOT	0.85 V/C	17.2	B	0.67	17.2	B	0.67
OR 99E / N REDWOOD STREET / SEQUOIA PARKWAY	Signal	ODOT	0.85 V/C	19.1	B	0.56	18.8	B	0.55

\* See narrative preceding Table 2 for note regarding v/c > 1.0. Conditions are overstated, and actual v/c is lower than reported.

\*\* The intersection of Sequoia Parkway/SE Hazeldell Way is assumed to be a signal in the future.

\*\*\* The intersection of SE 1st Avenue/S Walnut Road is assumed to include a roundabout with the Walnut Street extension.

BOLD values indicate performance measures failing to meet adopted mobility targets.



TABLE 7: 2022 PROJECT CONDITIONS INTERSECTION OPERATIONS (PM PEAK)

INTERSECTION	TRAFFIC CONTROL	JURISDICTION	MOBILITY STANDARD	2022 PROJECT CONDITIONS (WITHOUT S WALNUT EXTENSION TO OR 99E)			2022 PROJECT CONDITIONS (WITH S WALNUT EXTENSION TO OR 99E)		
				DELAY	LOS	V/C	DELAY	LOS	V/C
SE 1 <sup>ST</sup> AVENUE / HAINES ROAD / BREMER ROAD	TWSC	County	0.95 V/C	10.3	A/B	0.12	10.1	A/B	0.12
SE 1 <sup>ST</sup> AVENUE / S MULINO ROAD	TWSC	County	0.95 V/C	9.8	A/A	0.14	9.7	A/A	0.13
SE 1 <sup>ST</sup> AVENUE / S WALNUT ROAD	TWSC / Roundabout ***	County	0.95 V/C	9.1	A/A	0.05	4.2	A	0.10
SEQUOIA PARKWAY / S WALNUT ROAD	TWSC	City	LOS E, 0.90 V/C	11.0	A/B	0.09	11.1	A/B	0.07
SEQUOIA PARKWAY / SE HAZELDELL WAY	Signal**	City	LOS D, 0.85 V/C	25.0	C	0.51	25.6	C	0.51
OR 99E / HAINES ROAD	TWSC	ODOT	0.85 V/C	>200	B/F	1.53*	>200	B/F	1.53*
OR 99E / TERRITORIAL ROAD	Signal	ODOT	0.85 V/C	14.9	B	0.63	14.9	B	0.63
OR 99E / N REDWOOD STREET / SEQUOIA PARKWAY	Signal	ODOT	0.85 V/C	30.4	C	0.79	30.1	C	0.79

\* See narrative preceding Table 2 for note regarding v/c > 1.0. Conditions are overstated, and actual v/c is lower than reported.

\*\* The intersection of Sequoia Parkway/SE Hazeldell Way is assumed to be a signal in the future.

\*\*\* The intersection of SE 1st Avenue/S Walnut Road is assumed to include a roundabout with the Walnut Street extension.

BOLD values indicate performance measures failing to meet adopted mobility targets.

## TRANSPORTATION SYSTEM CONTEXT

The traffic volumes resulting from the proposed project on SE 1<sup>st</sup> Avenue were compared to existing traffic volumes, as well as the projected volumes from the **City's Transportation System Plan (TSP)** to provide an evaluation of growth on the roadway compared to planned conditions. A 24-hour weekday traffic volume was collected on SE 1<sup>st</sup> Avenue near the proposed site<sup>13</sup>. A comparison of the traffic volumes along this segment can be seen in Table 8. As shown, the annual growth that has occurred on SE 1<sup>st</sup> Avenue between 2009 and 2019 is slightly lower than the **annual growth that was projected in the City's TSP through 2030.**

SE 1<sup>st</sup> Avenue does not currently meet the cross-section requirements for standard collector streets, but once improved it should safely accommodate additional vehicle traffic consistent with the TSP forecast. Planned projects along key corridors in the area will also help serve growth. These projects include:

- Extending Walnut Road between SE 1st Avenue and OR 99E
- Upgrading SE 1st Avenue between Hazel Dell Way and S Mulino Road
- Constructing a roundabout at the S Mulino Road/SE 1st Avenue/S Bremer Road/S Haines Road intersection
- Constructing a roundabout at the S Township Road / S Mulino Road intersection
- Extending SE 4<sup>th</sup> Avenue between S. Sequoia Parkway and S Mulino Road

TABLE 8: VOLUME GROWTH COMPARISON ALONG SE 1<sup>ST</sup> AVENUE

PERIOD	ESTIMATED SITE TRIPS	CURRENT VOLUME (2019)	TOTAL 2019 VOLUME (SITE TRIPS + CURRENT VOLUME)	TSP VOLUME (2009) *	TSP ESTIMATED FUTURE VOLUME (2030) *	TSP FORECASTED ANNUAL GROWTH RATE (2030-2009)	REALIZED ANNUAL GROWTH RATE (TOTAL 2019-2009)
DAILY	949	1,045	1,994	--	--	--	--
AM PEAK HOUR	132	61	193	--	--	--	--
PM PEAK HOUR	144	109	253	145	860	23%	17%

\* Year 2009 and 2030 volumes are from 2010 City of Canby Transportation System Plan

<sup>13</sup> Count data collected on February 19, 2020 along SE 1<sup>st</sup> Avenue near the proposed site.

## SECTION 5. RECOMMENDATIONS

The following section summarizes the key findings and recommendations related to the proposed project.

### MOTOR VEHICLE IMPROVEMENTS

---

None of the study intersections were identified as having an impact based on projected growth from the proposed project. However, the OR 99E / Haines Road intersection fails to meet its mobility target under existing conditions and will continue to get worse with growth from background development and the proposed project. There is no clear mitigation measure to address the traffic conditions at the intersections. The intersection does not meet traffic signal warrants due to the low side street volume. Turn channelization has already been provided. The City of Canby TSP identifies this intersection as being substandard after all planned city improvements. Due to the low volume of traffic added to this location (approximately 20 or fewer trips per hour and less than one percent of total traffic) no improvement is recommended.

### SITE FRONTAGE RECOMMENDATIONS

The project site frontage along SE 1<sup>st</sup> Avenue and S Walnut Road are under City jurisdiction and designated as local roadways in the TSP but are expected to become industrial collector roadways upon adoption of the Walnut Street Extension TSP Amendment. A standard industrial collector roadway requires a 50-foot paved width (i.e., two 19-foot travel lanes and two 6-foot bike lanes) with sidewalks. These streets are recommended to be constructed to a modified version of the City industrial collector standard, consistent with surrounding development, as follows:

- SE 1<sup>st</sup> Avenue is recommended to include two 12-foot travel lanes and a 14-foot center turn lane, bike lanes (50-foot paved width), and sidewalks (consistent with SE Hazeldell Way)
- S Walnut Road is recommended to include two 12-foot travel lanes and a 6-foot striped median (30-foot paved width), sharrows for bike travel, and sidewalks (consistent with S Walnut Road south of the project site)

It is assumed that the City and the developer will work together determine required frontage improvements and right-of-way dedications.

### SITE ACCESS RECOMMENDATIONS

Access to the site is proposed via four driveways, two along S Walnut Road and two along SE 1<sup>st</sup> Avenue. Both SE 1<sup>st</sup> Avenue and S Walnut Road are classified as local streets in the TSP but are recommended to become collector roadways in the Walnut Street Extension TSP Amendment. The proposed southern driveway to S Walnut Road would be located near the south property line, located 150 feet closer than the 200-foot collector spacing standard. However, no operational or safety issues are anticipated due to the low number of vehicles using the existing driveway that serves a light industrial use. The proposed driveway also meets the 10-foot spacing standard for the existing local street designation, therefore no deviation to the Code will be required. However,



the applicant is encouraged to work with the property owner to the south to provide for a cross-over access easement and consolidate the two driveways.

Any project driveway that will serve trucks should be constructed to 50-foot widths. Driveways not serving trucks should be constructed according to the City of Canby access requirements for industrial uses.

#### SIGHT DISTANCE RECOMMENDATIONS

Preliminary sight distance evaluation from the accesses indicates that the proposed connections would be expected to provide adequate sight distance.

Prior to occupancy, sight distance at all access points will need to be verified, documented, and stamped by a registered professional Civil or Traffic Engineer licensed in the State of Oregon.

#### PEDESTRIAN/BICYCLE IMPROVEMENTS

---

Sidewalks and bike lanes are recommended to be included along the site frontage of SE 1<sup>st</sup> Avenue and sidewalks and sharrows are recommended along S Walnut Road. The proposed site also includes a sidewalk connection from both SE 1<sup>st</sup> Avenue and S Walnut Street to the building entrances, and sidewalks connecting the parking lots to the buildings.

# APPENDIX

# **Appendix**

---

**Peak Hour Traffic Count Data**

**Tube Count Data**

**HCM Analysis Reports**

**Crash Data (2015-2017)**



## **Peak Hour Traffic Count Data**

Data Provided by K-D-N.com 503-594-4224	
N/S street:	99E
E/W street:	N Redwood St
City, State	Canby OR
Study ID #	
Location	45.269037 - -122.67597
Start Date	Thursday, August 23, 2018
Start Time	07:00:00 AM
Peak Hour Start	07:00:00 AM
Peak 15 Min Start	07:35:00 AM
PHF (15-Min Int)	0.90

Peak-Hour Volumes (PHV)																							
Northbound				Southbound				Eastbound				Westbound				Entering				Leaving			
Left	Thru	Right	Uturn	Left	Thru	Right	Uturn	Left	Thru	Right	Uturn	Left	Thru	Right	Uturn	NB	SB	EB	WB	NB	SB	EB	WB
24	732	79	0	59	546	4	0	11	15	50	0	134	11	44	0	835	609	76	189	730	787	39	153

Percent Heavy Vehicles																							
4.2%	7.7%	2.5%	0.0%	10.2%	9.0%	0.0%	0.0%	0.0%	0.0%	2.0%	0.0%	5.2%	0.0%	18.2%	0.0%	7.1%	9.0%	1.3%	7.9%	7.8%	8.1%	2.6%	5.2%

PHV- Bicycles														PHV - Pedestrians							
Northbound				Southbound				Eastbound				Westbound				in Crosswalk					
Left	Thru	Right	Uturn	Left	Thru	Right	Uturn	Left	Thru	Right	Uturn	Left	Thru	Right	Uturn	Sum	NB	SB	EB	WB	Sum
0	0	0	0	0	0	0	0	0	0	0	0	0	0	0	0	0	0	1	0	1	2

All Vehicle Volumes																		
Time	Northbound				Southbound				Eastbound				Westbound				15 Min	1 HR
	99E				99E				N Redwood St				Sequoia Pkwy					
	Left	Thru	Right	Uturn	Left	Thru	Right	Uturn	Left	Thru	Right	Uturn	Left	Thru	Right	Uturn	Sum	Sum
07:00:00 AM	2	69	4	0	4	42	0	0	1	4	3	0	4	0	1	0		
07:05:00 AM	1	58	2	0	2	38	1	0	1	0	6	0	10	0	4	0		
07:10:00 AM	2	72	10	0	4	42	0	0	1	0	2	0	9	1	3	0	403	
07:15:00 AM	0	49	4	0	4	39	1	0	1	1	6	0	11	1	3	0	389	
07:20:00 AM	2	69	5	0	6	53	0	0	2	2	6	0	12	1	4	0	428	
07:25:00 AM	1	73	6	0	9	45	0	0	0	0	4	0	7	0	2	0	429	
07:30:00 AM	2	56	10	0	5	36	0	0	4	0	2	0	18	0	4	0	446	
07:35:00 AM	0	54	7	0	5	44	0	0	0	1	3	0	14	1	6	0	419	
07:40:00 AM	2	70	9	0	8	59	1	0	0	1	3	0	15	1	7	0	448	
07:45:00 AM	6	66	6	0	4	48	1	0	1	3	4	0	20	1	4	0	475	
07:50:00 AM	5	46	9	0	3	51	0	0	0	0	4	0	5	3	4	0	470	
07:55:00 AM	1	50	7	0	5	49	0	0	0	3	7	0	9	2	2	0	429	1709
08:00:00 AM	2	55	10	0	4	32	0	0	0	0	5	0	11	3	4	0	391	1701
08:05:00 AM	1	49	2	0	5	47	0	0	0	3	6	0	8	2	5	0	389	1706
08:10:00 AM	4	44	4	0	4	38	1	0	2	5	3	0	11	1	6	0	377	1683
08:15:00 AM	0	58	10	0	5	34	0	0	3	2	3	0	12	1	4	0	383	1695
08:20:00 AM	4	42	9	0	7	53	2	0	1	0	5	0	13	3	2	0	396	1674
08:25:00 AM	0	42	8	0	5	45	0	0	0	2	2	0	20	2	6	0	405	1659
08:30:00 AM	2	32	7	0	1	32	0	0	0	0	3	0	19	5	5	0	379	1628
08:35:00 AM	4	57	7	0	6	48	1	0	1	3	5	0	8	1	8	0	387	1642
08:40:00 AM	3	44	3	0	3	33	2	0	0	4	4	0	9	0	0	0	360	1571
08:45:00 AM	1	42	3	0	3	30	0	0	1	5	6	0	16	3	1	0	365	1518
08:50:00 AM	3	38	7	0	5	34	0	0	3	2	4	0	11	3	4	0	330	1502
08:55:00 AM	9	42	6	0	2	41	1	0	1	0	8	0	10	2	4	0	351	1493

Bicycles on Road																		
	Northbound				Southbound				Eastbound				Westbound					



KEY DATA NETWORK

Time	99E				99E				N Redwood St				Sequoia Pkwy				15 Min 1 HR	
	Left	Thru	Right	Utum	Left	Thru	Right	Utum	Left	Thru	Right	Utum	Left	Thru	Right	Utum	Sum	Sum
07:00:00 AM	0	0	0	0	0	0	0	0	0	0	0	0	0	0	0	0		
07:05:00 AM	0	0	0	0	0	0	0	0	0	0	0	0	0	0	0	0		
07:10:00 AM	0	0	0	0	0	0	0	0	0	0	0	0	0	0	0	0	0	0
07:15:00 AM	0	0	0	0	0	0	0	0	0	0	0	0	0	0	0	0	0	0
07:20:00 AM	0	0	0	0	0	0	0	0	0	0	0	0	0	0	0	0	0	0
07:25:00 AM	0	0	0	0	0	0	0	0	0	0	0	0	0	0	0	0	0	0
07:30:00 AM	0	0	0	0	0	0	0	0	0	0	0	0	0	0	0	0	0	0
07:35:00 AM	0	0	0	0	0	0	0	0	0	0	0	0	0	0	0	0	0	0
07:40:00 AM	0	0	0	0	0	0	0	0	0	0	0	0	0	0	0	0	0	0
07:45:00 AM	0	0	0	0	0	0	0	0	0	0	0	0	0	0	0	0	0	0
07:50:00 AM	0	0	0	0	0	0	0	0	0	0	0	0	0	0	0	0	0	0
07:55:00 AM	0	0	0	0	0	0	0	0	0	0	0	0	0	0	0	0	0	0
08:00:00 AM	0	1	0	0	0	0	0	0	0	0	0	0	0	0	0	0	1	1
08:05:00 AM	0	0	0	0	0	0	0	0	0	0	0	0	0	0	0	0	1	1
08:10:00 AM	0	0	0	0	0	0	0	0	0	0	0	0	0	0	0	0	1	1
08:15:00 AM	0	0	0	0	0	0	0	0	0	0	0	0	0	0	0	0	0	1
08:20:00 AM	0	0	0	0	0	0	0	0	0	0	0	0	0	0	0	0	0	1
08:25:00 AM	0	0	0	0	0	0	0	0	0	0	0	0	0	0	0	0	0	1
08:30:00 AM	0	0	0	0	0	0	0	0	0	0	0	0	0	0	0	0	0	1
08:35:00 AM	0	0	0	0	0	0	0	0	0	0	0	0	0	0	0	0	0	1
08:40:00 AM	0	0	0	0	0	0	0	0	0	0	0	0	0	0	0	0	0	1
08:45:00 AM	0	0	0	0	0	0	0	0	0	0	0	0	0	0	0	0	0	1
08:50:00 AM	0	0	0	0	0	0	0	0	0	0	0	0	0	0	0	0	0	1
08:55:00 AM	0	0	0	0	0	0	0	0	0	0	0	0	0	0	0	0	0	1

Passenger vehicles and light trucks

Time	Northbound				Southbound				Eastbound				Westbound				15 Min 1 HR	
	99E				99E				N Redwood St				Sequoia Pkwy				Sum	Sum
	Left	Thru	Right	Utum	Left	Thru	Right	Utum	Left	Thru	Right	Utum	Left	Thru	Right	Utum		
07:00:00 AM	1	63	4	0	3	39	0	0	1	4	3	0	4	0	1	0		
07:05:00 AM	1	55	2	0	2	30	1	0	1	0	6	0	10	0	3	0		
07:10:00 AM	2	68	10	0	4	41	0	0	1	0	2	0	9	1	3	0	375	
07:15:00 AM	0	46	4	0	3	36	1	0	1	1	6	0	11	1	3	0	365	
07:20:00 AM	2	65	5	0	6	48	0	0	2	2	5	0	9	1	3	0	402	
07:25:00 AM	1	67	5	0	8	42	0	0	0	0	4	0	7	0	2	0	397	
07:30:00 AM	2	54	9	0	5	33	0	0	4	0	2	0	18	0	2	0	413	
07:35:00 AM	0	50	7	0	4	39	0	0	0	1	3	0	14	1	6	0	390	
07:40:00 AM	2	63	9	0	8	55	1	0	0	1	3	0	14	1	7	0	418	
07:45:00 AM	6	56	6	0	3	47	1	0	1	3	4	0	19	1	3	0	439	
07:50:00 AM	5	43	9	0	2	44	0	0	0	0	4	0	4	3	2	0	430	
07:55:00 AM	1	46	7	0	5	43	0	0	0	3	7	0	8	2	1	0	389	1579
08:00:00 AM	2	47	8	0	4	29	0	0	0	0	5	0	10	1	4	0	349	1566
08:05:00 AM	0	40	1	0	4	43	0	0	0	3	6	0	8	2	5	0	345	1567
08:10:00 AM	4	38	4	0	3	34	1	0	2	5	3	0	8	1	6	0	331	1535
08:15:00 AM	0	49	9	0	4	31	0	0	3	2	3	0	11	1	4	0	338	1539
08:20:00 AM	3	37	9	0	6	49	2	0	1	0	5	0	11	3	2	0	354	1519
08:25:00 AM	0	38	8	0	5	41	0	0	0	2	2	0	20	2	4	0	367	1505





KEY DATA NETWORK

08:30:00 AM	2	29	5	0	1	30	0	0	0	0	3	0	18	4	5	0	347	1473
08:35:00 AM	4	52	7	0	5	43	1	0	1	3	4	0	8	1	4	0	352	1481
08:40:00 AM	3	42	2	0	3	29	2	0	0	4	4	0	9	0	0	0	328	1415
08:45:00 AM	1	36	3	0	3	26	0	0	1	5	6	0	16	2	1	0	331	1365
08:50:00 AM	3	34	6	0	3	32	0	0	3	2	4	0	11	3	4	0	303	1354
08:55:00 AM	7	37	6	0	2	34	1	0	1	0	7	0	10	1	4	0	315	1341

FHWA 4-13 -Truck/Multi-Unit/Heavy Trucks

Time	Northbound				Southbound				Eastbound				Westbound				15 Min	1 HR
	99E				99E				N Redwood St				Sequoia Pkwy					
	Left	Thru	Right	Utum	Left	Thru	Right	Utum	Left	Thru	Right	Utum	Left	Thru	Right	Utum		
07:00:00 AM	1	6	0	0	1	3	0	0	0	0	0	0	0	0	0	0		
07:05:00 AM	0	3	0	0	0	8	0	0	0	0	0	0	0	0	1	0		
07:10:00 AM	0	4	0	0	0	1	0	0	0	0	0	0	0	0	0	0	28	
07:15:00 AM	0	3	0	0	1	3	0	0	0	0	0	0	0	0	0	0	24	
07:20:00 AM	0	4	0	0	0	5	0	0	0	0	1	0	3	0	1	0	26	
07:25:00 AM	0	6	1	0	1	3	0	0	0	0	0	0	0	0	0	0	32	
07:30:00 AM	0	2	1	0	0	3	0	0	0	0	0	0	0	0	2	0	33	
07:35:00 AM	0	4	0	0	1	5	0	0	0	0	0	0	0	0	0	0	29	
07:40:00 AM	0	7	0	0	0	4	0	0	0	0	0	0	1	0	0	0	30	
07:45:00 AM	0	10	0	0	1	1	0	0	0	0	0	0	1	0	1	0	36	
07:50:00 AM	0	3	0	0	1	7	0	0	0	0	0	0	1	0	2	0	40	
07:55:00 AM	0	4	0	0	0	6	0	0	0	0	0	0	1	0	1	0	40	130
08:00:00 AM	0	8	2	0	0	3	0	0	0	0	0	0	1	2	0	0	42	135
08:05:00 AM	1	9	1	0	1	4	0	0	0	0	0	0	0	0	0	0	44	139
08:10:00 AM	0	6	0	0	1	4	0	0	0	0	0	0	3	0	0	0	46	148
08:15:00 AM	0	9	1	0	1	3	0	0	0	0	0	0	1	0	0	0	45	156
08:20:00 AM	1	5	0	0	1	4	0	0	0	0	0	0	2	0	0	0	42	155
08:25:00 AM	0	4	0	0	0	4	0	0	0	0	0	0	0	0	2	0	38	154
08:30:00 AM	0	3	2	0	0	2	0	0	0	0	0	0	1	1	0	0	32	155
08:35:00 AM	0	5	0	0	1	5	0	0	0	0	1	0	0	0	4	0	35	161
08:40:00 AM	0	2	1	0	0	4	0	0	0	0	0	0	0	0	0	0	32	156
08:45:00 AM	0	6	0	0	0	4	0	0	0	0	0	0	0	1	0	0	34	153
08:50:00 AM	0	4	1	0	2	2	0	0	0	0	0	0	0	0	0	0	27	148
08:55:00 AM	2	5	0	0	0	7	0	0	0	0	1	0	0	1	0	0	36	152

Pedestrians Crossing

15 Min 1 HR

Time	NB	SB	EB	WB	Sum	Sum
07:00:00 AM	0	0	0	0		
07:05:00 AM	0	0	0	0		
07:10:00 AM	0	0	0	0	0	
07:15:00 AM	0	0	0	0	0	
07:20:00 AM	0	0	0	0	0	
07:25:00 AM	0	1	0	1	2	
07:30:00 AM	0	0	0	0	2	
07:35:00 AM	0	0	0	0	2	
07:40:00 AM	0	0	0	0	0	
07:45:00 AM	0	0	0	0	0	
07:50:00 AM	0	0	0	0	0	
07:55:00 AM	0	0	0	0	0	2



KEY DATA NETWORK

08:00:00 AM	0	0	0	0	0	2
08:05:00 AM	0	0	0	0	0	2
08:10:00 AM	0	1	0	0	1	3
08:15:00 AM	0	0	0	0	1	3
08:20:00 AM	0	0	0	0	1	3
08:25:00 AM	0	0	0	0	0	1
08:30:00 AM	0	1	0	0	1	2
08:35:00 AM	0	1	0	0	2	3
08:40:00 AM	0	0	0	0	2	3
08:45:00 AM	0	0	0	0	1	3
08:50:00 AM	0	0	0	0	0	3
08:55:00 AM	0	1	0	1	2	5



Southbound  
99E  
Heavy Vehicle 9.0%

In	609	Out	787	
Bicycles	Right	Thru	Left	U-Turn

0	4	546	59	0
---	---	-----	----	---

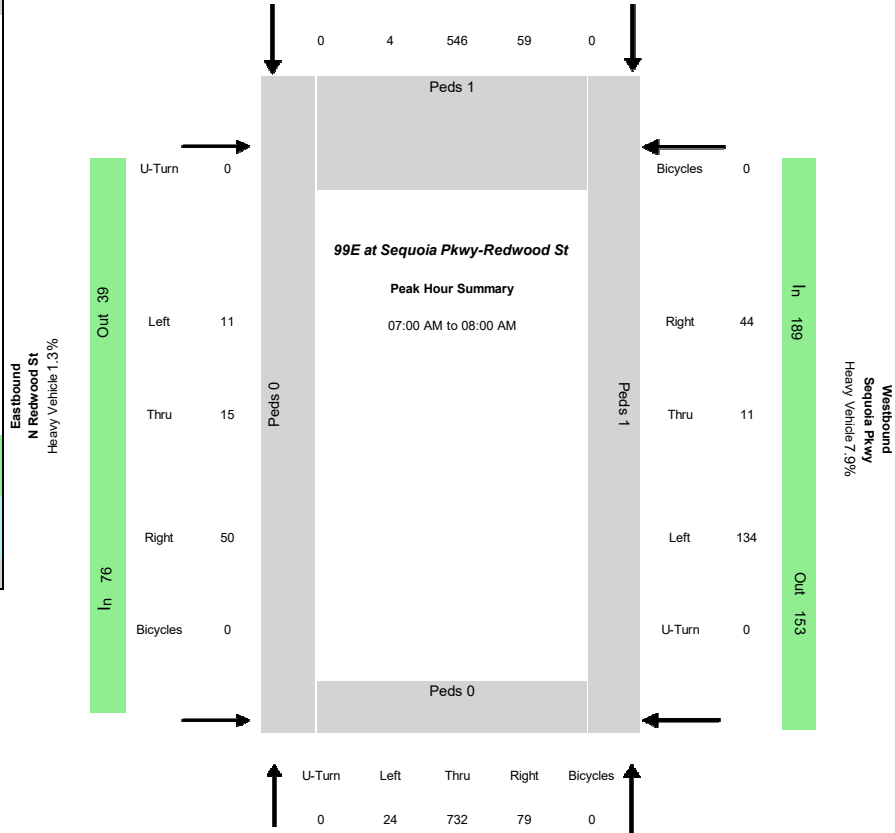

In	835	Out	730
----	-----	-----	-----

Heavy Vehicle 7.1%  
99E  
Northbound

Peak-Hour Volumes (PHV)																							
Northbound				Southbound				Eastbound				Westbound				Entering				Leaving			
Left	Thru	Right	Uturn	Left	Thru	Right	Uturn	Left	Thru	Right	Uturn	Left	Thru	Right	Uturn	NB	SB	EB	WB	NB	SB	EB	WB
24	732	79	0	59	546	4	0	11	15	50	0	134	11	44	0	835	609	76	189	730	787	39	153
4.2%	7.7%	2.5%	0.0%	10.2%	9.0%	0.0%	0.0%	0.0%	0.0%	2.0%	0.0%	5.2%	0.0%	18.2%	0.0%	7.1%	9.0%	1.3%	7.9%	7.8%	8.1%	2.6%	5.2%

PHV - Bicycles												PHV - Pedestrians									
Northbound				Southbound				Eastbound				Westbound				in Crosswalk					
Left	Thru	Right	Uturn	Left	Thru	Right	Uturn	Left	Thru	Right	Uturn	Left	Thru	Right	Uturn	Sum	NB	SB	EB	WB	Sum
0	0	0	0	0	0	0	0	0	0	0	0	0	0	0	0	0	0	1	0	1	2

Time	Northbound 99E				Southbound 99E				Eastbound N Redwood St				Westbound Sequoia Pkwy				15 Min Sum	1 HR Sum
	Left	Thru	Right	Uturn	Left	Thru	Right	Uturn	Left	Thru	Right	Uturn	Left	Thru	Right	Uturn		
07:00:00 AM	2	69	4	0	4	42	0	0	1	4	3	0	4	0	1	0		
07:05:00 AM	1	58	2	0	2	38	1	0	1	0	6	0	10	0	4	0		
07:10:00 AM	2	72	10	0	4	42	0	0	1	0	2	0	9	1	3	0	403	
07:15:00 AM	0	49	4	0	4	39	1	0	1	1	6	0	11	1	3	0	389	
07:20:00 AM	2	69	5	0	6	53	0	0	2	2	6	0	12	1	4	0	428	
07:25:00 AM	1	73	6	0	9	45	0	0	0	0	4	0	7	0	2	0	429	
07:30:00 AM	2	56	10	0	5	36	0	0	4	0	2	0	18	0	4	0	446	
07:35:00 AM	0	54	7	0	5	44	0	0	0	1	3	0	14	1	6	0	419	
07:40:00 AM	2	70	9	0	8	59	1	0	0	1	3	0	15	1	7	0	448	
07:45:00 AM	6	66	6	0	4	48	1	0	1	3	4	0	20	1	4	0	475	
07:50:00 AM	5	46	9	0	3	51	0	0	0	0	4	0	5	3	4	0	470	
07:55:00 AM	1	50	7	0	5	49	0	0	0	3	7	0	9	2	2	0	429	1709
08:00:00 AM	2	55	10	0	4	32	0	0	0	0	5	0	11	3	4	0	391	1701
08:05:00 AM	1	49	2	0	5	47	0	0	0	3	6	0	8	2	5	0	389	1706
08:10:00 AM	4	44	4	0	4	38	1	0	2	5	3	0	11	1	6	0	377	1683
08:15:00 AM	0	58	10	0	5	34	0	0	3	2	3	0	12	1	4	0	383	1695
08:20:00 AM	4	42	9	0	7	53	2	0	1	0	5	0	13	3	2	0	396	1674
08:25:00 AM	0	42	8	0	5	45	0	0	0	2	2	0	20	2	6	0	405	1659
08:30:00 AM	2	32	7	0	1	32	0	0	0	0	3	0	19	5	5	0	379	1628
08:35:00 AM	4	57	7	0	6	48	1	0	1	3	5	0	8	1	8	0	387	1642
08:40:00 AM	3	44	3	0	3	33	2	0	0	4	4	0	9	0	0	0	360	1571
08:45:00 AM	1	42	3	0	3	30	0	0	1	5	6	0	16	3	1	0	365	1518
08:50:00 AM	3	38	7	0	5	34	0	0	3	2	4	0	11	3	4	0	330	1502
08:55:00 AM	9	42	6	0	2	41	1	0	1	0	8	0	10	2	4	0	351	1493

Data Provided by K-D-N.com 503-594-4224	
N/S street:	99E
E/W street:	N Redwood St
City, State	Canby OR
Study ID #	
Location	45.269037 - -122.67597
Start Date	Thursday, August 23, 2018
Start Time	04:00:00 PM
Peak Hour Start	04:05:00 PM
Peak 15 Min Start	04:05:00 PM
PHF (15-Min Int)	0.91

Peak-Hour Volumes (PHV)																							
Northbound				Southbound				Eastbound				Westbound				Entering				Leaving			
Left	Thru	Right	Uturn	Left	Thru	Right	Uturn	Left	Thru	Right	Uturn	Left	Thru	Right	Uturn	NB	SB	EB	WB	NB	SB	EB	WB
62	764	114	0	131	1015	19	0	6	71	39	0	321	59	93	0	940	1165	116	473	1375	863	140	316

Percent Heavy Vehicles																							
0.0%	5.1%	3.5%	0.0%	0.8%	4.1%	0.0%	0.0%	0.0%	1.4%	5.1%	0.0%	1.2%	0.0%	4.3%	0.0%	4.6%	3.7%	2.6%	1.7%	3.5%	5.0%	0.0%	1.9%

PHV- Bicycles														PHV - Pedestrians							
Northbound				Southbound				Eastbound				Westbound				in Crosswalk					
Left	Thru	Right	Uturn	Left	Thru	Right	Uturn	Left	Thru	Right	Uturn	Left	Thru	Right	Uturn	Sum	NB	SB	EB	WB	Sum
0	0	0	0	0	0	0	0	0	1	0	0	0	0	0	0	1	0	6	0	4	10

All Vehicle Volumes																				
Time	Northbound				Southbound				Eastbound				Westbound				15 Min		1 HR	
	99E				99E				N Redwood St				Sequoia Pkwy				Sum	Sum		
	Left	Thru	Right	Uturn	Left	Thru	Right	Uturn	Left	Thru	Right	Uturn	Left	Thru	Right	Uturn				
04:00:00 PM	5	61	7	0	8	68	1	0	0	6	0	0	32	7	7	0				
04:05:00 PM	3	86	8	0	8	96	2	0	0	2	2	0	46	3	10	0				
04:10:00 PM	10	64	12	0	14	103	3	0	1	6	2	0	17	2	6	0	708			
04:15:00 PM	7	67	10	0	10	75	4	0	1	8	9	0	31	6	7	0	741			
04:20:00 PM	3	54	9	0	6	89	0	0	1	14	2	0	32	6	9	0	700			
04:25:00 PM	7	67	9	0	15	110	1	0	0	2	3	0	19	3	8	0	704			
04:30:00 PM	4	70	11	0	8	87	2	0	1	7	2	0	26	7	4	0	698			
04:35:00 PM	5	78	11	0	14	80	0	0	0	4	6	0	25	6	9	0	711			
04:40:00 PM	2	53	11	0	9	81	2	0	0	4	4	0	21	4	4	0	662			
04:45:00 PM	6	40	5	0	14	73	2	0	0	6	5	0	28	2	13	0	627			
04:50:00 PM	1	57	11	0	6	67	1	0	0	6	3	0	29	10	8	0	588			
04:55:00 PM	5	81	7	0	15	80	1	0	1	2	1	0	20	3	4	0	613	2687		
05:00:00 PM	9	47	10	0	12	74	1	0	1	10	0	0	27	7	11	0	628	2694		
05:05:00 PM	11	84	10	0	6	79	1	0	0	6	2	0	15	6	5	0	654	2653		
05:10:00 PM	8	48	9	0	13	87	3	0	0	4	6	0	23	7	6	0	648	2627		
05:15:00 PM	5	78	18	0	9	89	1	0	0	6	5	0	28	6	5	0	689	2642		
05:20:00 PM	6	67	13	0	14	93	2	0	0	3	5	0	17	5	6	0	695	2648		
05:25:00 PM	7	60	8	0	15	83	3	0	1	5	2	0	31	6	9	0	711	2634		
05:30:00 PM	5	57	10	0	12	78	0	0	0	4	5	0	20	3	7	0	662	2606		
05:35:00 PM	3	66	13	0	11	96	1	0	0	5	3	0	22	5	4	0	660	2597		
05:40:00 PM	7	58	13	0	18	48	4	0	1	5	2	0	25	3	4	0	618	2590		
05:45:00 PM	5	70	4	0	11	99	1	0	1	2	7	0	21	3	5	0	646	2625		
05:50:00 PM	3	58	11	0	10	61	1	0	0	6	4	0	27	5	2	0	605	2614		
05:55:00 PM	6	61	9	0	11	83	2	0	2	6	2	0	33	5	5	0	642	2619		

Bicycles on Road																	
	Northbound				Southbound				Eastbound				Westbound				





KEY DATA NETWORK

Time	99E				99E				N Redwood St				Sequoia Pkwy				15 Min	1 HR
	Left	Thru	Right	Utum	Left	Thru	Right	Utum	Left	Thru	Right	Utum	Left	Thru	Right	Utum	Sum	Sum
04:00:00 PM	0	0	0	0	0	0	0	0	0	0	0	0	0	0	0	0		
04:05:00 PM	0	0	0	0	0	0	0	0	0	0	0	0	0	0	0	0		
04:10:00 PM	0	0	0	0	0	0	0	0	0	0	0	0	0	0	0	0	0	0
04:15:00 PM	0	0	0	0	0	0	0	0	0	0	0	0	0	0	0	0	0	0
04:20:00 PM	0	0	0	0	0	0	0	0	0	0	0	0	0	0	0	0	0	0
04:25:00 PM	0	0	0	0	0	0	0	0	0	0	0	0	0	0	0	0	0	0
04:30:00 PM	0	0	0	0	0	0	0	0	0	1	0	0	0	0	0	0	1	1
04:35:00 PM	0	0	0	0	0	0	0	0	0	0	0	0	0	0	0	0	1	1
04:40:00 PM	0	0	0	0	0	0	0	0	0	0	0	0	0	0	0	0	1	1
04:45:00 PM	0	0	0	0	0	0	0	0	0	0	0	0	0	0	0	0	0	0
04:50:00 PM	0	0	0	0	0	0	0	0	0	0	0	0	0	0	0	0	0	0
04:55:00 PM	0	0	0	0	0	0	0	0	0	0	0	0	0	0	0	0	0	1
05:00:00 PM	0	0	0	0	0	0	0	0	0	0	0	0	0	0	0	0	0	1
05:05:00 PM	0	0	0	0	0	0	0	0	0	0	0	0	0	0	0	0	0	1
05:10:00 PM	0	0	0	0	0	0	0	0	0	0	0	0	0	0	0	0	0	1
05:15:00 PM	0	0	0	0	0	0	0	0	0	0	0	0	0	0	0	0	0	1
05:20:00 PM	0	0	0	0	0	0	0	0	0	0	0	0	0	0	0	0	0	1
05:25:00 PM	0	0	0	0	0	0	0	0	0	0	0	0	0	0	0	0	0	1
05:30:00 PM	0	0	0	0	0	0	0	0	0	0	0	0	0	0	0	0	0	0
05:35:00 PM	0	0	0	0	0	0	0	0	0	0	0	0	0	0	0	0	0	0
05:40:00 PM	0	0	0	0	0	0	0	0	0	0	0	0	0	0	0	0	0	0
05:45:00 PM	0	0	0	0	0	0	0	0	0	0	0	0	0	0	0	0	0	0
05:50:00 PM	0	0	0	0	0	0	0	0	0	0	0	0	0	0	0	0	0	0
05:55:00 PM	0	1	0	0	0	0	0	0	0	0	0	0	0	0	0	0	1	1

Passenger vehicles and light trucks

Time	Northbound				Southbound				Eastbound				Westbound				15 Min	1 HR
	99E				99E				N Redwood St				Sequoia Pkwy				Sum	Sum
	Left	Thru	Right	Utum	Left	Thru	Right	Utum	Left	Thru	Right	Utum	Left	Thru	Right	Utum		
04:00:00 PM	4	58	6	0	7	68	1	0	0	5	0	0	30	7	7	0		
04:05:00 PM	3	78	7	0	8	90	2	0	0	2	2	0	46	3	9	0		
04:10:00 PM	10	60	11	0	14	98	3	0	1	6	2	0	17	2	6	0	673	
04:15:00 PM	7	64	10	0	10	73	4	0	1	8	9	0	29	6	6	0	707	
04:20:00 PM	3	52	9	0	6	87	0	0	1	14	2	0	32	6	9	0	678	
04:25:00 PM	7	61	9	0	15	107	1	0	0	2	2	0	19	3	7	0	681	
04:30:00 PM	4	67	10	0	8	82	2	0	1	7	2	0	26	7	4	0	674	
04:35:00 PM	5	75	11	0	14	76	0	0	0	4	5	0	25	6	9	0	683	
04:40:00 PM	2	52	11	0	8	80	2	0	0	4	4	0	21	4	4	0	642	
04:45:00 PM	6	38	5	0	14	67	2	0	0	6	5	0	27	2	12	0	606	
04:50:00 PM	1	55	11	0	6	64	1	0	0	5	3	0	29	10	8	0	569	
04:55:00 PM	5	80	7	0	15	78	1	0	1	2	1	0	19	3	4	0	593	2589
05:00:00 PM	9	43	9	0	12	71	1	0	1	10	0	0	27	7	11	0	610	2597
05:05:00 PM	11	81	10	0	6	76	1	0	0	6	2	0	15	6	5	0	636	2566
05:10:00 PM	8	48	8	0	12	79	3	0	0	4	6	0	23	7	6	0	624	2540
05:15:00 PM	5	76	17	0	9	87	1	0	0	6	5	0	27	6	5	0	667	2557
05:20:00 PM	6	66	12	0	14	90	2	0	0	3	5	0	17	5	6	0	674	2562
05:25:00 PM	7	59	8	0	15	81	3	0	1	5	2	0	31	6	9	0	697	2556



KEY DATA NETWORK

05:30:00 PM	5	56	10	0	12	75	0	0	0	4	5	0	20	3	6	0	649	2532
05:35:00 PM	3	65	12	0	11	93	1	0	0	5	3	0	22	5	4	0	647	2526
05:40:00 PM	7	56	13	0	18	45	4	0	1	4	2	0	25	3	3	0	601	2515
05:45:00 PM	5	66	4	0	11	96	1	0	1	2	7	0	19	3	5	0	625	2551
05:50:00 PM	3	55	11	0	9	57	1	0	0	6	4	0	27	5	2	0	581	2538
05:55:00 PM	6	60	9	0	11	83	2	0	2	6	2	0	33	5	5	0	624	2546

FHWA 4-13 -Truck/Multi-Unit/Heavy Trucks

Time	Northbound 99E				Southbound 99E				Eastbound N Redwood St				Westbound Sequoia Pkwy				15 Min 1 HR	
	Left	Thru	Right	Utum	Left	Thru	Right	Utum	Left	Thru	Right	Utum	Left	Thru	Right	Utum	Sum	Sum
	04:00:00 PM	1	3	1	0	1	0	0	0	0	1	0	0	2	0	0	0	
04:05:00 PM	0	8	1	0	0	6	0	0	0	0	0	0	0	0	1	0		
04:10:00 PM	0	4	1	0	0	5	0	0	0	0	0	0	0	0	0	0	35	
04:15:00 PM	0	3	0	0	0	2	0	0	0	0	0	0	2	0	1	0	34	
04:20:00 PM	0	2	0	0	0	2	0	0	0	0	0	0	0	0	0	0	22	
04:25:00 PM	0	6	0	0	0	3	0	0	0	0	1	0	0	0	1	0	23	
04:30:00 PM	0	3	1	0	0	5	0	0	0	0	0	0	0	0	0	0	24	
04:35:00 PM	0	3	0	0	0	4	0	0	0	0	1	0	0	0	0	0	28	
04:40:00 PM	0	1	0	0	1	1	0	0	0	0	0	0	0	0	0	0	20	
04:45:00 PM	0	2	0	0	0	6	0	0	0	0	0	0	1	0	1	0	21	
04:50:00 PM	0	2	0	0	0	3	0	0	0	0	1	0	0	0	0	0	19	
04:55:00 PM	0	1	0	0	0	2	0	0	0	0	0	0	1	0	0	0	20	98
05:00:00 PM	0	4	1	0	0	3	0	0	0	0	0	0	0	0	0	0	18	97
05:05:00 PM	0	3	0	0	0	3	0	0	0	0	0	0	0	0	0	0	18	87
05:10:00 PM	0	0	1	0	1	8	0	0	0	0	0	0	0	0	0	0	24	87
05:15:00 PM	0	2	1	0	0	2	0	0	0	0	0	0	1	0	0	0	22	85
05:20:00 PM	0	1	1	0	0	3	0	0	0	0	0	0	0	0	0	0	21	86
05:25:00 PM	0	1	0	0	0	2	0	0	0	0	0	0	0	0	0	0	14	78
05:30:00 PM	0	1	0	0	0	3	0	0	0	0	0	0	0	0	1	0	13	74
05:35:00 PM	0	1	1	0	0	3	0	0	0	0	0	0	0	0	0	0	13	71
05:40:00 PM	0	2	0	0	0	3	0	0	0	0	1	0	0	0	1	0	17	75
05:45:00 PM	0	4	0	0	0	3	0	0	0	0	0	0	2	0	0	0	21	74
05:50:00 PM	0	3	0	0	1	4	0	0	0	0	0	0	0	0	0	0	24	76
05:55:00 PM	0	1	0	0	0	0	0	0	0	0	0	0	0	0	0	0	18	73

Pedestrians Crossing

15 Min 1 HR

Time	NB	SB	EB	WB	Sum	Sum
04:00:00 PM	0	1	0	1		
04:05:00 PM	0	1	0	1		
04:10:00 PM	0	0	0	1	5	
04:15:00 PM	0	2	0	0	5	
04:20:00 PM	0	0	0	0	3	
04:25:00 PM	0	0	0	0	2	
04:30:00 PM	0	1	0	0	1	
04:35:00 PM	0	0	0	0	1	
04:40:00 PM	0	0	0	1	2	
04:45:00 PM	0	1	0	0	2	
04:50:00 PM	0	1	0	0	3	
04:55:00 PM	0	0	0	0	2	11



KEY DATA NETWORK

05:00:00 PM	0	0	0	1	2	10
05:05:00 PM	0	0	0	0	1	8
05:10:00 PM	0	0	0	0	1	7
05:15:00 PM	0	1	0	1	2	7
05:20:00 PM	0	0	0	1	3	8
05:25:00 PM	0	1	0	0	4	9
05:30:00 PM	0	0	0	0	2	8
05:35:00 PM	0	1	0	1	3	10
05:40:00 PM	0	0	0	0	2	9
05:45:00 PM	0	0	0	0	2	8
05:50:00 PM	0	0	0	0	0	7
05:55:00 PM	0	0	0	1	1	8



Data Provided by K-D-N.com 503-594-4224	
N/S street	99E
E/W street	N Redwood St
City, State	Canby OR
Site Notes	
Location	45.269037 - -122.67597
Start Date	Thursday, August 23, 2018
Start Time	04:00:00 PM
Weather	
Study ID #	
Peak Hour Start	04:05:00 PM
Peak 15 Min Start	04:05:00 PM
PHF (15-Min Int)	0.91

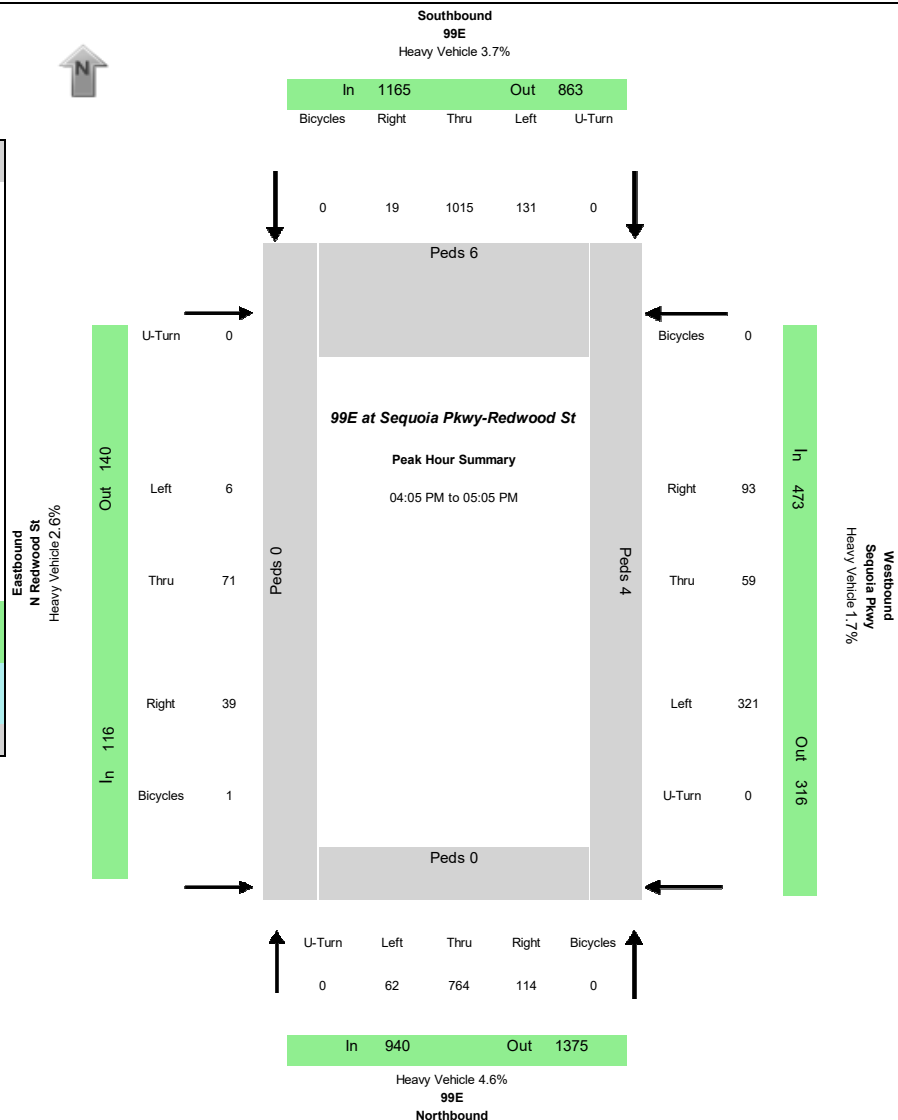

Peak-Hour Volumes (PHV)																							
Northbound				Southbound				Eastbound				Westbound				Entering				Leaving			
Left	Thru	Right	Uturn	Left	Thru	Right	Uturn	Left	Thru	Right	Uturn	Left	Thru	Right	Uturn	NB	SB	EB	WB	NB	SB	EB	WB
62	764	114	0	131	1015	19	0	6	71	39	0	321	59	93	0	940	1165	116	473	1375	863	140	316
Percent Heavy Vehicles																							
0.0%	5.1%	3.5%	0.0%	0.8%	4.1%	0.0%	0.0%	0.0%	1.4%	5.1%	0.0%	1.2%	0.0%	4.3%	0.0%	4.6%	3.7%	2.6%	1.7%	3.5%	5.0%	0.0%	1.9%

PHV - Bicycles														PHV - Pedestrians							
Northbound				Southbound				Eastbound				Westbound				Sum	in Crosswalk				
Left	Thru	Right	Uturn	Left	Thru	Right	Uturn	Left	Thru	Right	Uturn	Left	Thru	Right	Uturn	Sum	NB	SB	EB	WB	Sum
0	0	0	0	0	0	0	0	0	1	0	0	0	0	0	0	1	0	6	0	4	10

Time	Northbound 99E				Southbound 99E				Eastbound N Redwood St				Westbound Sequoia Pkwy				15 Min Sum	1 HR Sum	
	Left	Thru	Right	Uturn	Left	Thru	Right	Uturn	Left	Thru	Right	Uturn	Left	Thru	Right	Uturn			
04:00:00 PM	5	61	7	0	8	68	1	0	0	6	0	0	0	32	7	7	0		
04:05:00 PM	3	86	8	0	8	96	2	0	0	2	2	0	0	46	3	10	0		
04:10:00 PM	10	64	12	0	14	103	3	0	1	6	2	0	17	2	6	0	708		
04:15:00 PM	7	67	10	0	10	75	4	0	1	8	9	0	31	6	7	0	741		
04:20:00 PM	3	54	9	0	6	89	0	0	1	14	2	0	32	6	9	0	700		
04:25:00 PM	7	67	9	0	15	110	1	0	0	2	3	0	19	3	8	0	704		
04:30:00 PM	4	70	11	0	8	87	2	0	1	7	2	0	26	7	4	0	698		
04:35:00 PM	5	78	11	0	14	80	0	0	0	4	6	0	25	6	9	0	711		
04:40:00 PM	2	53	11	0	9	81	2	0	0	4	4	0	21	4	4	0	662		
04:45:00 PM	6	40	5	0	14	73	2	0	0	6	5	0	28	2	13	0	627		
04:50:00 PM	1	57	11	0	6	67	1	0	0	6	3	0	29	10	8	0	588		
04:55:00 PM	5	81	7	0	15	80	1	0	1	2	1	0	20	3	4	0	613	2687	
05:00:00 PM	9	47	10	0	12	74	1	0	1	10	0	0	27	7	11	0	628	2694	
05:05:00 PM	11	84	10	0	6	79	1	0	0	6	2	0	15	6	5	0	654	2653	
05:10:00 PM	8	48	9	0	13	87	3	0	0	4	6	0	23	7	6	0	648	2627	
05:15:00 PM	5	78	18	0	9	89	1	0	0	6	5	0	28	6	5	0	689	2642	
05:20:00 PM	6	67	13	0	14	93	2	0	0	3	5	0	17	5	6	0	695	2648	
05:25:00 PM	7	60	8	0	15	83	3	0	1	5	2	0	31	6	9	0	711	2634	
05:30:00 PM	5	57	10	0	12	78	0	0	0	4	5	0	20	3	7	0	662	2606	
05:35:00 PM	3	66	13	0	11	96	1	0	0	5	3	0	22	5	4	0	660	2597	
05:40:00 PM	7	58	13	0	18	48	4	0	1	5	2	0	25	3	4	0	618	2590	
05:45:00 PM	5	70	4	0	11	99	1	0	1	2	7	0	21	3	5	0	646	2625	
05:50:00 PM	3	58	11	0	10	61	1	0	0	6	4	0	27	5	2	0	605	2614	
05:55:00 PM	6	61	9	0	11	83	2	0	2	6	2	0	33	5	5	0	642	2619	



Data Provided by K-D-N.com 503-594-4224

N/S street	OR 99E
E/W street	NE Territorial Rd
City, State	Canby OR
Site Notes	
Location	45.279365 - -122.666025
Start Date	Thursday, October 04, 2018
Start Time	07:00:00 AM
Weather	
Study ID #	
Peak Hour Start	07:00:00 AM
Peak 15 Min Start	07:35:00 AM
PHF (15-Min Int)	0.89

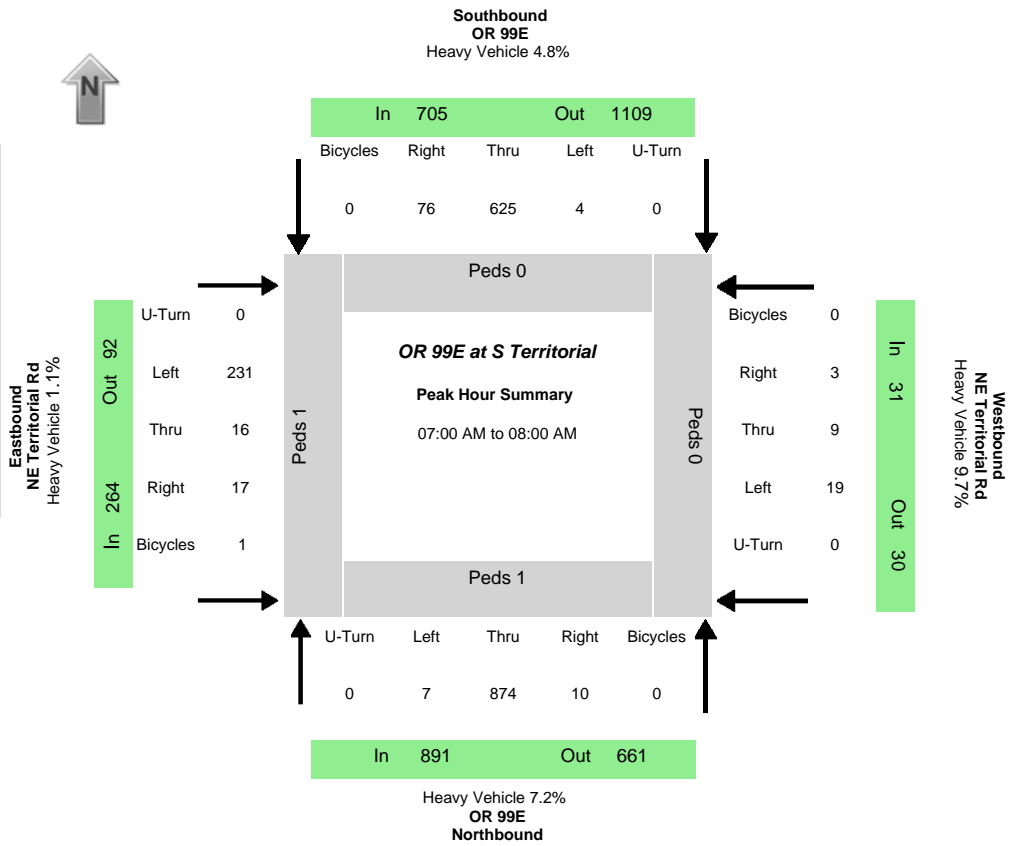

Peak-Hour Volumes (PHV)																							
Northbound				Southbound				Eastbound				Westbound				Entering				Leaving			
Left	Thru	Right	Uturn	Left	Thru	Right	Uturn	Left	Thru	Right	Uturn	Left	Thru	Right	Uturn	NB	SB	EB	WB	NB	SB	EB	WB
7	874	10	0	4	625	76	0	231	16	17	0	19	9	3	0	891	705	264	31	661	1108	92	30
Percent Heavy Vehicles																							
14.3%	7.2%	0.0%	0.0%	75.0%	4.6%	2.6%	0.0%	0.9%	0.0%	5.9%	0.0%	5.3%	11.1%	33.3%	0.0%	7.2%	4.8%	1.1%	9.7%	4.7%	6.0%	4.3%	10.0%

PHV - Bicycles																PHV - Pedestrians					
Northbound				Southbound				Eastbound				Westbound				Sum	in Crosswalk				Sum
Left	Thru	Right	Uturn	Left	Thru	Right	Uturn	Left	Thru	Right	Uturn	Left	Thru	Right	Uturn		NB	SB	EB	WB	
0	0	0	0	0	0	0	0	1	0	0	0	0	0	0	0	1	1	0	1	0	2

Time	Northbound OR 99E				Southbound OR 99E				Eastbound NE Territorial Rd				Westbound NE Territorial Rd				15 Min Sum	1 HR Sum
	Left	Thru	Right	Uturn	Left	Thru	Right	Uturn	Left	Thru	Right	Uturn	Left	Thru	Right	Uturn		
	07:00:00 AM	0	79	2	0	0	46	4	0	15	1	0	0	2	1	0		
07:05:00 AM	0	67	0	0	1	33	2	0	23	1	1	0	0	0	0	0		
07:10:00 AM	2	77	1	0	0	56	8	0	27	1	2	0	3	1	0	0	456	
07:15:00 AM	0	63	1	0	0	46	8	0	21	4	1	0	2	1	0	0	453	
07:20:00 AM	1	63	0	0	0	54	13	0	14	0	5	0	0	0	0	0	475	
07:25:00 AM	0	84	0	0	1	51	8	0	22	2	0	0	2	0	1	0	468	
07:30:00 AM	3	79	2	0	1	42	5	0	26	1	1	0	1	1	0	0	483	
07:35:00 AM	1	98	2	0	1	61	5	0	20	1	1	0	2	1	0	0	526	
07:40:00 AM	0	74	1	0	0	62	5	0	19	2	1	0	1	0	0	0	520	
07:45:00 AM	0	79	0	0	0	65	3	0	19	0	3	0	2	1	0	0	530	
07:50:00 AM	0	53	1	0	0	51	8	0	10	1	2	0	4	1	0	0	468	
07:55:00 AM	0	58	0	0	0	58	7	0	15	2	0	0	0	2	2	0	447	1891
08:00:00 AM	1	64	0	0	0	50	3	0	16	1	2	0	0	1	0	0	413	1879
08:05:00 AM	0	51	0	0	0	48	3	0	7	0	5	0	1	2	0	0	399	1868
08:10:00 AM	0	67	1	0	0	48	6	0	9	1	0	0	1	1	0	0	389	1824
08:15:00 AM	2	59	1	0	0	45	10	0	18	1	0	0	2	3	0	0	392	1818
08:20:00 AM	1	57	0	0	0	61	6	0	6	0	1	0	0	2	0	0	409	1802
08:25:00 AM	1	60	0	0	0	47	5	0	12	0	1	0	1	2	0	0	404	1760
08:30:00 AM	1	51	0	0	0	38	6	0	14	2	2	0	1	0	0	0	378	1713
08:35:00 AM	1	56	1	0	1	46	8	0	9	0	1	0	1	1	0	0	369	1645
08:40:00 AM	1	57	0	0	0	39	9	0	20	1	1	0	1	0	0	0	369	1609
08:45:00 AM	2	54	3	0	0	48	8	0	9	0	0	0	0	1	1	0	380	1563
08:50:00 AM	0	56	1	0	0	59	6	0	15	3	0	0	0	3	0	0	398	1575
08:55:00 AM	1	61	2	0	0	30	6	0	8	2	0	0	1	2	1	0	383	1545

Data Provided by K-D-N.com 503-594-4224

N/S street	OR 99E
E/W street	NE Territorial Rd
City, State	Canby OR
Site Notes	
Location	45.279365 - -122.666025
Start Date	Thursday, October 04, 2018
Start Time	04:00:00 PM
Weather	
Study ID #	
Peak Hour Start	04:00:00 PM
Peak 15 Min Start	04:35:00 PM
PHF (15-Min Int)	0.96

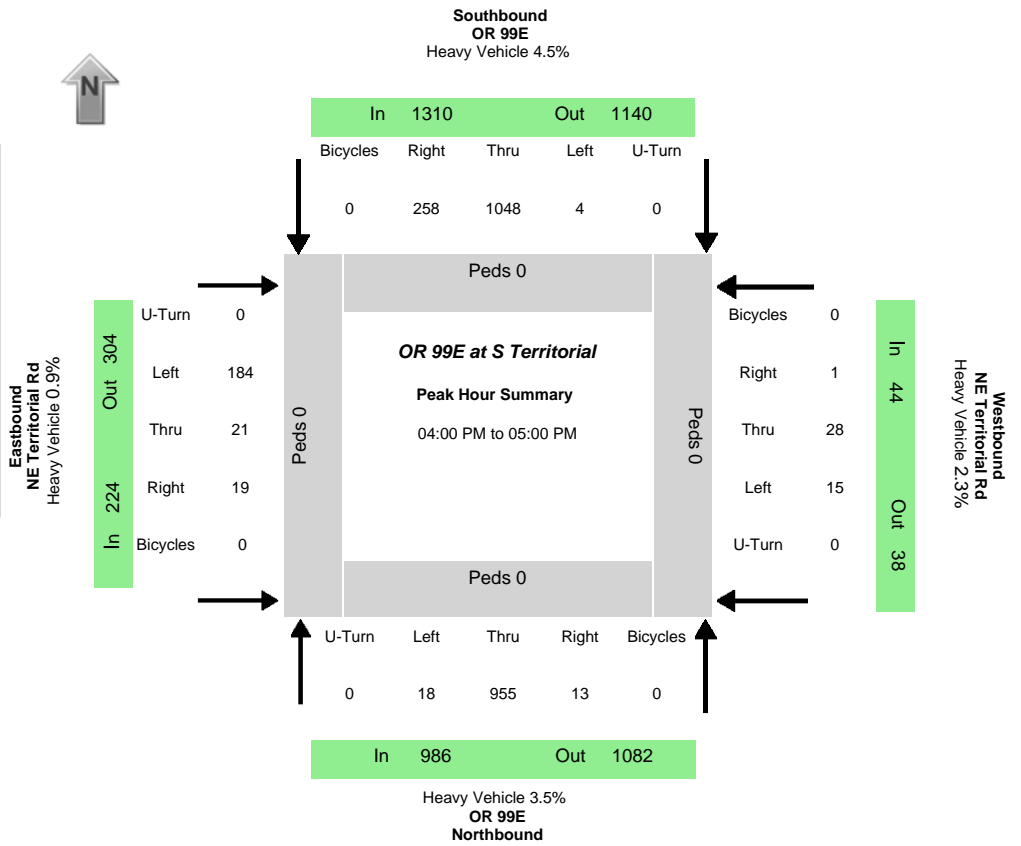

Peak-Hour Volumes (PHV)

Northbound				Southbound				Eastbound				Westbound				Entering				Leaving			
Left	Thru	Right	Uturn	Left	Thru	Right	Uturn	Left	Thru	Right	Uturn	Left	Thru	Right	Uturn	NB	SB	EB	WB	NB	SB	EB	WB
18	955	13	0	4	1048	258	0	184	21	19	0	15	28	1	0	986	1310	224	44	1082	1140	304	38

Percent Heavy Vehicles

0.0%	3.5%	15.4%	0.0%	25.0%	5.2%	1.2%	0.0%	0.5%	0.0%	5.3%	0.0%	6.7%	0.0%	0.0%	0.0%	3.5%	4.5%	0.9%	2.3%	5.3%	3.0%	1.0%	7.9%
------	------	-------	------	-------	------	------	------	------	------	------	------	------	------	------	------	------	------	------	------	------	------	------	------

PHV - Bicycles

Northbound				Southbound				Eastbound				Westbound				Sum	PHV - Pedestrians				
Left	Thru	Right	Uturn	Left	Thru	Right	Uturn	Left	Thru	Right	Uturn	Left	Thru	Right	Uturn		in Crosswalk				Sum
0	0	0	0	0	0	0	0	0	0	0	0	0	0	0	0	0	NB	SB	EB	WB	0

All Vehicle Volumes

Time	Northbound OR 99E				Southbound OR 99E				Eastbound NE Territorial Rd				Westbound NE Territorial Rd				15 Min Sum	1 HR Sum
	Left	Thru	Right	Uturn	Left	Thru	Right	Uturn	Left	Thru	Right	Uturn	Left	Thru	Right	Uturn		
04:00:00 PM	2	81	0	0	0	83	17	0	6	2	1	0	2	2	1	0		
04:05:00 PM	1	77	0	0	0	99	23	0	19	4	1	0	0	3	0	0		
04:10:00 PM	0	84	5	0	0	90	23	0	12	1	0	0	2	3	0	0	644	
04:15:00 PM	1	75	1	0	1	79	16	0	16	1	2	0	3	3	0	0	645	
04:20:00 PM	0	82	1	0	0	94	29	0	11	2	4	0	1	1	0	0	643	
04:25:00 PM	1	79	1	0	0	84	17	0	11	2	1	0	1	2	0	0	622	
04:30:00 PM	1	79	1	0	1	88	14	0	13	1	1	0	2	2	0	0	627	
04:35:00 PM	3	77	1	0	0	82	18	0	18	5	1	0	0	3	0	0	610	
04:40:00 PM	1	76	1	0	0	99	25	0	19	2	5	0	1	2	0	0	642	
04:45:00 PM	4	84	0	0	0	98	19	0	25	0	0	0	0	1	0	0	670	
04:50:00 PM	2	76	0	0	1	65	25	0	19	1	2	0	2	4	0	0	659	
04:55:00 PM	2	85	2	0	1	87	32	0	15	0	1	0	1	2	0	0	656	2564
05:00:00 PM	2	62	0	0	0	88	14	0	11	0	0	0	1	1	0	0	604	2546
05:05:00 PM	1	89	0	0	0	85	23	0	14	3	3	0	0	3	0	0	628	2540
05:10:00 PM	0	67	0	0	2	101	19	0	16	1	0	0	0	1	0	0	607	2527
05:15:00 PM	4	78	1	0	1	73	28	0	22	0	1	0	0	4	0	0	640	2541
05:20:00 PM	0	75	1	0	0	85	22	0	14	0	5	0	0	2	0	0	623	2520
05:25:00 PM	4	79	1	0	0	94	20	0	11	2	1	0	2	2	0	0	632	2537
05:30:00 PM	0	68	0	0	0	89	21	0	27	5	2	0	3	3	1	0	639	2553
05:35:00 PM	4	72	1	0	0	89	20	0	17	2	2	0	1	1	0	0	644	2554
05:40:00 PM	2	73	0	0	0	70	10	0	17	2	4	0	1	0	1	0	608	2503
05:45:00 PM	2	65	1	0	1	85	16	0	0	0	2	0	1	1	1	0	564	2447
05:50:00 PM	2	63	1	0	0	90	16	0	17	2	2	0	0	0	2	0	550	2445
05:55:00 PM	8	67	1	0	0	68	22	0	15	3	0	0	1	2	0	0	557	2404

Data Provided by K-D-N.com 503-594-4224

N/S street	OR 99E
E/W street	S Haines Rd
City, State	Canby OR
Site Notes	
Location	45.288198 - -122.656044
Start Date	Thursday, October 04, 2018
Start Time	07:00:00 AM
Weather	
Study ID #	
Peak Hour Start	07:00:00 AM
Peak 15 Min Start	07:30:00 AM
PHF (15-Min Int)	0.86

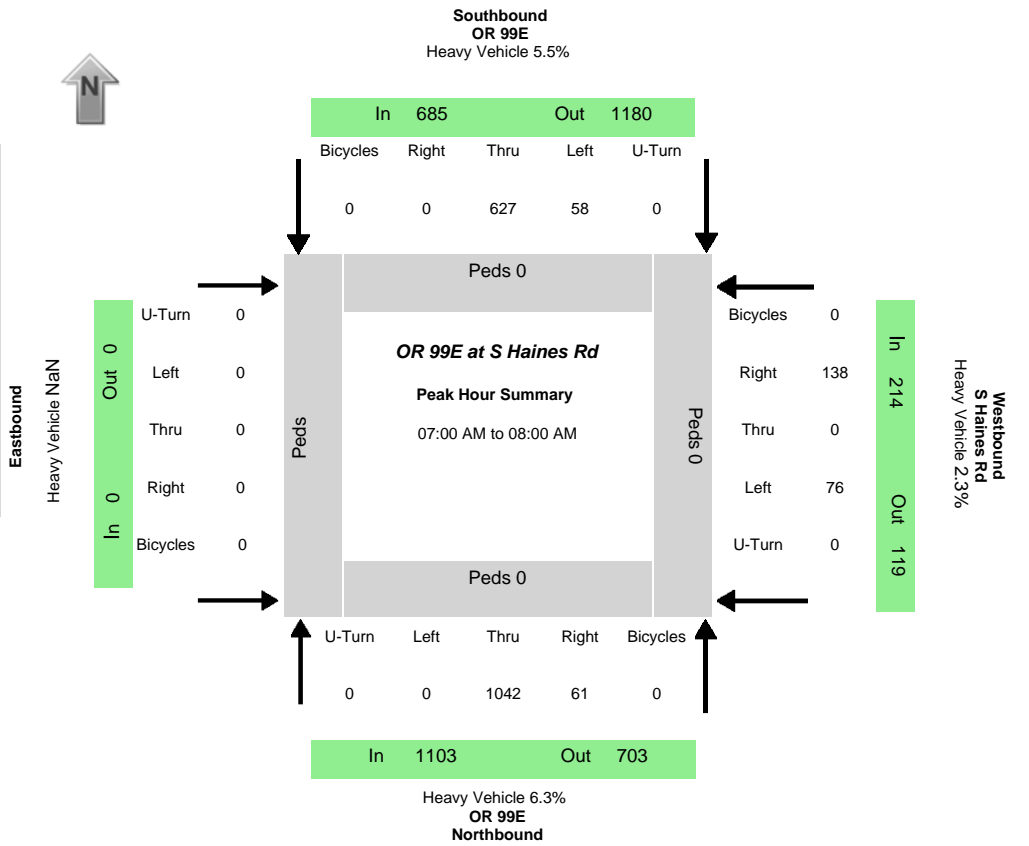

Peak-Hour Volumes (PHV)																							
Northbound				Southbound				Eastbound				Westbound				Entering				Leaving			
Left	Thru	Right	Uturn	Left	Thru	Right	Uturn	Left	Thru	Right	Uturn	Left	Thru	Right	Uturn	NB	SB	EB	WB	NB	SB	EB	WB
0	1042	61	0	58	627	0	0	0	0	0	0	76	0	138	0	1103	685	0	214	703	1180	0	119
Percent Heavy Vehicles																							
0.0%	6.5%	1.6%	0.0%	5.2%	5.6%	0.0%	0.0%	0.0%	0.0%	0.0%	0.0%	6.6%	0.0%	0.0%	0.0%	6.3%	5.5%	NaN	2.3%	5.7%	5.8%	NaN	3.4%

PHV - Bicycles												PHV - Pedestrians									
Northbound				Southbound				Eastbound				Westbound				in Crosswalk					
Left	Thru	Right	Uturn	Left	Thru	Right	Uturn	Left	Thru	Right	Uturn	Left	Thru	Right	Uturn	Sum	NB	SB	EB	WB	Sum
0	0	0	0	0	0	0	0	0	0	0	0	0	0	0	0	0	0	0	0	0	0

Time	Northbound OR 99E				Southbound OR 99E				Eastbound				Westbound S Haines Rd				15 Min Sum	1 HR Sum
	Left	Thru	Right	Uturn	Left	Thru	Right	Uturn	Left	Thru	Right	Uturn	Left	Thru	Right	Uturn		
07:00:00 AM	90	4	0	0	3	38	0	0	0	0	0	0	5	13	0	0	473	
07:05:00 AM	71	7	0	0	9	49	0	0	0	0	0	0	4	7	0	0	480	
07:10:00 AM	110	2	0	0	2	38	0	0	0	0	0	0	6	15	0	0	503	
07:15:00 AM	73	6	0	0	5	57	0	0	0	0	0	0	6	13	0	0	517	
07:20:00 AM	81	1	0	0	3	67	0	0	0	0	0	0	4	14	0	0	542	
07:25:00 AM	89	5	0	0	6	40	0	0	0	0	0	0	6	7	0	0	579	
07:30:00 AM	109	10	0	0	1	46	0	0	0	0	0	0	10	18	0	0	554	
07:35:00 AM	102	7	0	0	3	56	0	0	0	0	0	0	7	20	0	0	504	
07:40:00 AM	92	5	0	0	5	68	0	0	0	0	0	0	8	12	0	0	467	2002
07:45:00 AM	88	5	0	0	7	58	0	0	0	0	0	0	5	6	0	0	442	1993
07:50:00 AM	71	1	0	0	8	54	0	0	0	0	0	0	5	6	0	0	427	1976
07:55:00 AM	66	8	0	0	6	56	0	0	0	0	0	0	10	7	0	0	414	1943
08:00:00 AM	70	6	0	0	5	46	0	0	0	0	0	0	3	14	0	0	423	1936
08:05:00 AM	55	4	0	0	3	50	0	0	0	0	0	0	5	13	0	0	428	1901
08:10:00 AM	75	7	0	0	2	48	0	0	0	0	0	0	4	4	0	0	433	1893
08:15:00 AM	72	2	0	0	8	56	0	0	0	0	0	0	6	9	0	0	398	1817
08:20:00 AM	62	1	0	0	3	58	0	0	0	0	0	0	5	6	0	0	401	1760
08:25:00 AM	70	9	0	0	2	51	0	0	0	0	0	0	2	11	0	0	385	1699
08:30:00 AM	50	7	0	0	3	41	0	0	0	0	0	0	7	10	0	0	416	1679
08:35:00 AM	72	1	0	0	0	51	0	0	0	0	0	0	5	9	0	0	403	1659
08:40:00 AM	69	3	0	0	4	44	0	0	0	0	0	0	7	2	0	0	403	1659
08:45:00 AM	67	8	0	0	8	56	0	0	0	0	0	0	5	5	0	0	403	1659
08:50:00 AM	63	5	0	0	1	48	0	0	0	0	0	0	4	4	0	0	403	1659
08:55:00 AM	71	2	0	0	5	40	0	0	0	0	0	0	4	7	0	0	403	1635

Data Provided by K-D-N.com 503-594-4224

N/S street	OR 99E
E/W street	S Haines Rd
City, State	Canby OR
Site Notes	
Location	45.288198 - -122.656044
Start Date	Thursday, October 04, 2018
Start Time	04:00:00 PM
Weather	
Study ID #	
Peak Hour Start	04:30:00 PM
Peak 15 Min Start	05:10:00 PM
PHF (15-Min Int)	0.96

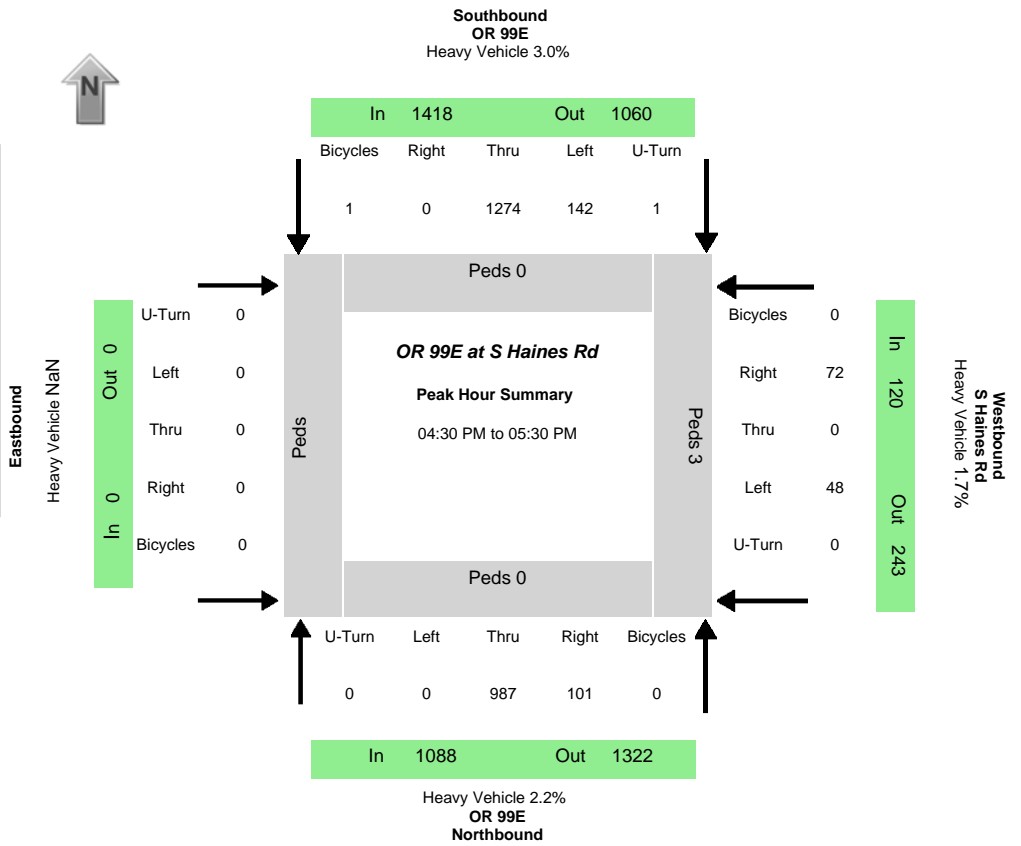

Peak-Hour Volumes (PHV)																							
Northbound				Southbound				Eastbound				Westbound				Entering				Leaving			
Left	Thru	Right	Uturn	Left	Thru	Right	Uturn	Left	Thru	Right	Uturn	Left	Thru	Right	Uturn	NB	SB	EB	WB	NB	SB	EB	WB
0	987	101	0	142	1274	0	1	0	0	0	0	48	0	72	0	1088	1417	0	120	1322	1060	0	243
Percent Heavy Vehicles																							
0.0%	2.3%	1.0%	0.0%	0.0%	3.4%	0.0%	0.0%	0.0%	0.0%	0.0%	0.0%	2.1%	0.0%	1.4%	0.0%	2.2%	3.0%	NaN	1.7%	3.3%	2.3%	NaN	0.4%

PHV - Bicycles												PHV - Pedestrians									
Northbound				Southbound				Eastbound				Westbound				in Crosswalk					
Left	Thru	Right	Uturn	Left	Thru	Right	Uturn	Left	Thru	Right	Uturn	Left	Thru	Right	Uturn	Sum	NB	SB	EB	WB	Sum
0	0	0	0	0	1	0	0	0	0	0	0	0	0	0	0	1	0	0	0	3	3

Time	Northbound OR 99E				Southbound OR 99E				Eastbound				Westbound S Haines Rd				15 Min Sum	1 HR Sum
	Left	Thru	Right	Uturn	Left	Thru	Right	Uturn	Left	Thru	Right	Uturn	Left	Thru	Right	Uturn		
04:00:00 PM	96	6	0	0	15	117	0	0					1	3	0	0		
04:05:00 PM	79	10	1	0	15	121	0	0					5	6	0	0		
04:10:00 PM	67	4	0	0	8	105	0	0					6	7	0	0	672	
04:15:00 PM	84	12	0	0	8	89	0	0					4	9	0	0	640	
04:20:00 PM	80	9	0	0	13	121	0	0					3	4	0	0	633	
04:25:00 PM	63	8	0	0	13	99	0	0					2	10	0	0	631	
04:30:00 PM	87	3	0	0	11	106	0	0					1	7	0	0	640	
04:35:00 PM	77	10	0	0	18	105	0	0					5	4	0	0	629	
04:40:00 PM	78	9	0	0	13	111	0	0					5	7	0	0	657	
04:45:00 PM	78	11	0	0	9	115	0	0					1	3	0	0	659	
04:50:00 PM	93	11	0	0	9	84	0	0					3	8	0	0	648	
04:55:00 PM	81	8	0	0	6	104	0	0					4	9	0	0	637	2597
05:00:00 PM	73	6	0	0	12	105	0	0					4	4	0	0	624	2563
05:05:00 PM	77	15	0	0	13	107	0	0					1	8	0	0	637	2547
05:10:00 PM	84	6	0	0	10	121	0	0					8	3	0	0	657	2582
05:15:00 PM	92	8	0	0	11	91	1	0					6	7	0	0	669	2592
05:20:00 PM	85	5	0	0	16	116	0	0					6	8	0	0	684	2598
05:25:00 PM	82	9	0	0	14	109	0	0					4	4	0	0	674	2625
05:30:00 PM	83	7	0	0	16	92	0	0					4	5	0	0	665	2617
05:35:00 PM	84	7	0	0	8	92	0	0					0	4	0	0	624	2593
05:40:00 PM	74	6	0	0	7	94	0	0					2	2	0	0	587	2555
05:45:00 PM	74	10	0	0	14	104	0	0					7	6	0	0	595	2553
05:50:00 PM	18	0	0	0	1	26	0	0					1	1	0	0	447	2392



Data Provided by K-D-N.com 503-594-4224

N/S street	<b>Sequoia Pkwy</b>
E/W street	<b>Hazeldell Way</b>
City, State	Canby OR
Site Notes	
Location	45.267388 - -122.674783
Start Date	Thursday, August 23, 2018
Start Time	07:00:00 AM
Weather	
Study ID #	
<b>Peak Hour Start</b>	<b>07:35:00 AM</b>
<b>Peak 15 Min Start</b>	<b>07:35:00 AM</b>
<b>PHF (15-Min Int)</b>	<b>0.89</b>

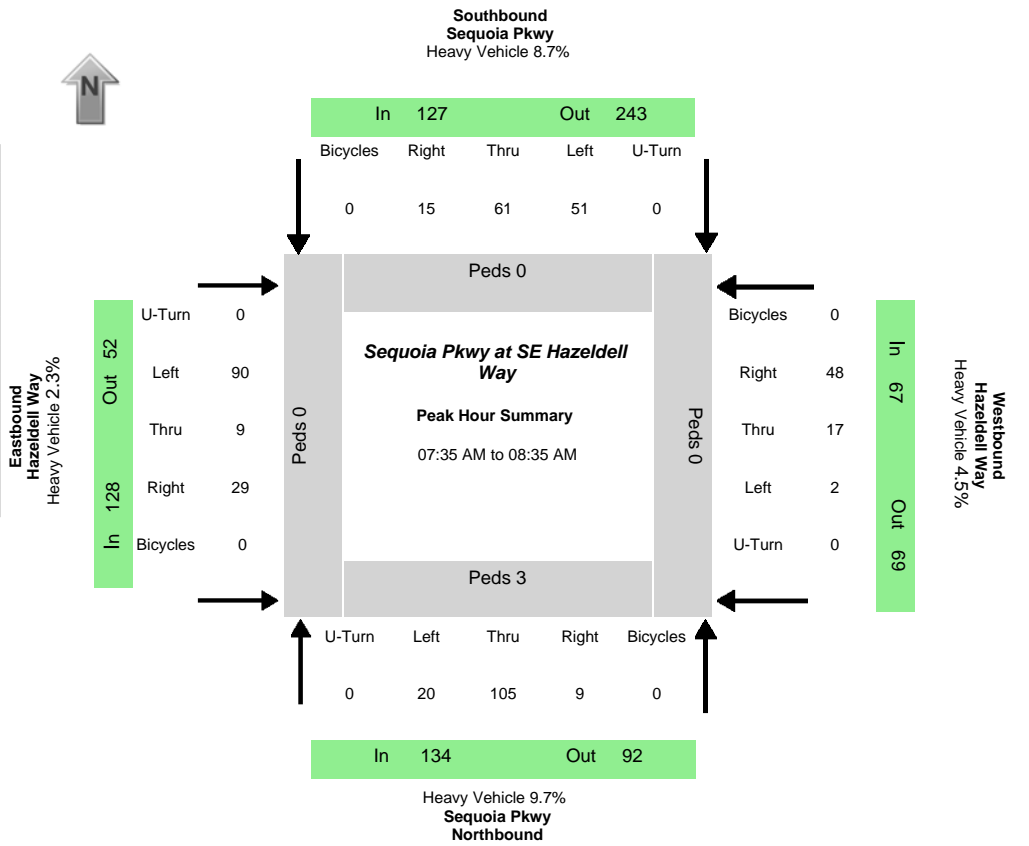

Peak-Hour Volumes (PHV)																							
Northbound				Southbound				Eastbound				Westbound				Entering				Leaving			
Left	Thru	Right	Uturn	Left	Thru	Right	Uturn	Left	Thru	Right	Uturn	Left	Thru	Right	Uturn	NB	SB	EB	WB	NB	SB	EB	WB
20	105	9	0	51	61	15	0	90	9	29	0	2	17	48	0	134	127	128	67	92	243	52	69
Percent Heavy Vehicles																							
10.0%	9.5%	11.1%	0.0%	0.0%	16.4%	6.7%	0.0%	3.3%	0.0%	0.0%	0.0%	0.0%	0.0%	6.3%	0.0%	9.7%	8.7%	2.3%	4.5%	10.9%	6.6%	5.8%	1.4%

PHV - Bicycles														PHV - Pedestrians							
Northbound				Southbound				Eastbound				Westbound				in Crosswalk					
Left	Thru	Right	Uturn	Left	Thru	Right	Uturn	Left	Thru	Right	Uturn	Left	Thru	Right	Uturn	Sum	NB	SB	EB	WB	Sum
0	0	0	0	0	0	0	0	0	0	0	0	0	0	0	0	0	3	0	0	0	3

Time	Northbound Sequoia Pkwy				Southbound Sequoia Pkwy				Eastbound Hazeldell Way				Westbound Hazeldell Way				15 Min Sum	1 HR Sum		
	Left	Thru	Right	Uturn	Left	Thru	Right	Uturn	Left	Thru	Right	Uturn	Left	Thru	Right	Uturn				
07:00:00 AM	3	6	1	0	5	4	0	0	0	0	1	0	0	0	0	0	1	0		
07:05:00 AM	0	8	0	0	0	2	0	0	0	4	0	2	0	0	0	1	2	0		
07:10:00 AM	5	3	1	0	1	10	1	0	7	0	4	0	0	0	1	2	0	75		
07:15:00 AM	1	6	0	0	2	4	2	0	6	0	0	0	0	0	1	3	0	79		
07:20:00 AM	1	9	0	0	2	6	2	0	7	3	3	0	0	0	0	3	0	96		
07:25:00 AM	5	11	0	0	3	11	3	0	1	1	2	0	0	0	0	2	0	100		
07:30:00 AM	2	7	0	0	3	5	2	0	7	0	2	0	0	0	1	4	0	108		
07:35:00 AM	1	12	1	0	1	3	5	0	7	1	1	0	0	0	1	3	0	108		
07:40:00 AM	3	12	0	0	11	3	1	0	9	1	8	0	0	0	1	3	0	121		
07:45:00 AM	1	7	1	0	4	6	0	0	16	0	0	0	0	0	2	3	0	128		
07:50:00 AM	3	4	1	0	2	9	0	0	4	0	3	0	0	0	2	3	0	123		
07:55:00 AM	2	7	0	0	3	9	2	0	6	2	1	0	0	0	1	3	0	107	403	
08:00:00 AM	0	8	0	0	2	7	2	0	4	0	4	0	1	1	7	0	103	418		
08:05:00 AM	1	7	1	0	2	6	0	0	6	0	2	0	0	5	3	0	105	432		
08:10:00 AM	4	7	3	0	1	6	1	0	4	0	2	0	0	1	6	0	104	432		
08:15:00 AM	0	9	1	0	8	4	0	0	7	2	3	0	0	0	2	0	104	443		
08:20:00 AM	2	9	0	0	7	5	1	0	6	1	3	0	0	1	4	0	110	446		
08:25:00 AM	3	12	1	0	6	1	1	0	12	2	2	0	0	1	3	0	119	451		
08:30:00 AM	0	11	0	0	4	2	2	0	9	0	0	0	1	1	8	0	121	456		
08:35:00 AM	0	8	0	0	4	4	1	0	5	2	2	0	0	1	3	0	112	450		
08:40:00 AM	0	3	1	0	2	6	1	0	5	0	2	0	0	0	3	0	91	421		
08:45:00 AM	1	10	0	0	1	5	4	0	6	1	3	0	0	2	3	0	89	417		
08:50:00 AM	0	9	0	0	5	5	0	0	9	2	2	0	0	1	3	0	95	422		
08:55:00 AM	3	7	1	0	3	3	0	0	6	1	1	0	0	0	2	0	99	413		

Data Provided by K-D-N.com 503-594-4224	
N/S street	<b>Sequoia Pkwy</b>
E/W street	<b>Hazeldell Way</b>
City, State	Canby OR
Site Notes	
Location	45.267388 - -122.674783
Start Date	Thursday, August 23, 2018
Start Time	04:00:00 PM
Weather	
Study ID #	
<b>Peak Hour Start</b>	<b>04:05:00 PM</b>
<b>Peak 15 Min Start</b>	<b>04:30:00 PM</b>
<b>PHF (15-Min Int)</b>	<b>0.95</b>

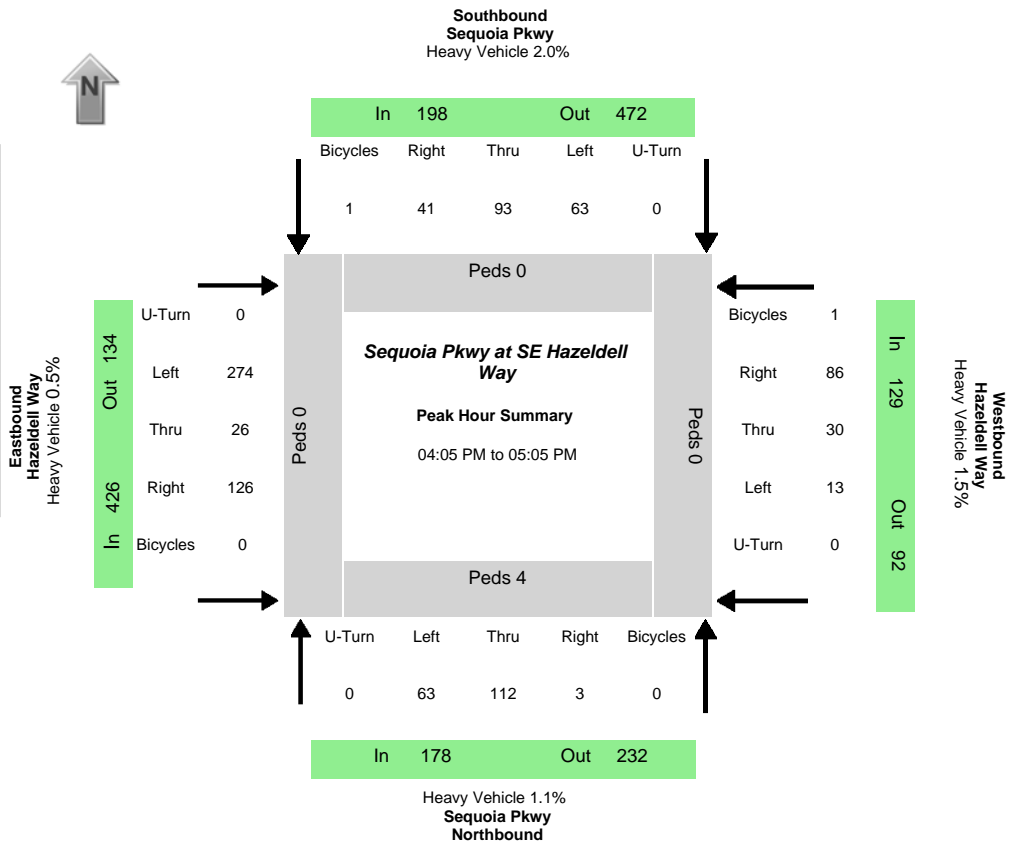

Peak-Hour Volumes (PHV)																							
Northbound				Southbound				Eastbound				Westbound				Entering				Leaving			
Left	Thru	Right	Uturn	Left	Thru	Right	Uturn	Left	Thru	Right	Uturn	Left	Thru	Right	Uturn	NB	SB	EB	WB	NB	SB	EB	WB
63	112	3	0	63	93	41	0	274	26	126	0	13	30	86	0	178	197	426	129	232	472	134	92
Percent Heavy Vehicles																							
0.0%	1.8%	0.0%	0.0%	3.2%	2.2%	0.0%	0.0%	0.7%	0.0%	0.0%	0.0%	0.0%	0.0%	2.3%	0.0%	1.1%	2.0%	0.5%	1.6%	0.9%	1.3%	0.0%	2.2%

PHV - Bicycles														PHV - Pedestrians							
Northbound				Southbound				Eastbound				Westbound				in Crosswalk					
Left	Thru	Right	Uturn	Left	Thru	Right	Uturn	Left	Thru	Right	Uturn	Left	Thru	Right	Uturn	Sum	NB	SB	EB	WB	Sum
0	0	0	0	0	1	0	0	0	0	0	0	0	1	0	0	2	4	0	0	0	4

Time	Northbound Sequoia Pkwy				Southbound Sequoia Pkwy				Eastbound Hazeldell Way				Westbound Hazeldell Way				15 Min Sum	1 HR Sum	
	Left	Thru	Right	Uturn	Left	Thru	Right	Uturn	Left	Thru	Right	Uturn	Left	Thru	Right	Uturn			
04:00:00 PM	1	24	0	0	5	9	2	0	18	2	7	0	0	2	6	0	0		
04:05:00 PM	8	18	0	0	4	4	2	0	20	0	7	0	1	1	7	0			
04:10:00 PM	2	8	0	0	8	7	6	0	22	1	9	0	0	2	8	0	221		
04:15:00 PM	6	9	1	0	7	6	1	0	18	1	9	0	1	8	10	0	222		
04:20:00 PM	7	6	0	0	5	9	3	0	28	2	12	0	2	1	8	0	233		
04:25:00 PM	5	9	0	0	5	7	6	0	24	5	8	0	0	0	7	0	236		
04:30:00 PM	6	10	1	0	6	9	6	0	23	1	8	0	1	2	6	0	238		
04:35:00 PM	6	9	1	0	6	9	5	0	16	4	11	0	1	4	5	0	232		
04:40:00 PM	6	8	0	0	5	10	3	0	24	5	13	0	1	6	7	0	244		
04:45:00 PM	5	12	0	0	4	7	2	0	22	0	12	0	0	0	8	0	237		
04:50:00 PM	6	8	0	0	4	9	2	0	30	4	13	0	2	1	5	0	244		
04:55:00 PM	1	5	0	0	4	6	2	0	23	2	11	0	1	4	5	0	220	921	
05:00:00 PM	5	10	0	0	5	10	3	0	24	1	13	0	3	1	10	0	233	930	
05:05:00 PM	5	4	0	0	6	7	3	0	21	4	14	0	0	4	2	0	219	928	
05:10:00 PM	3	16	3	0	5	7	4	0	16	1	10	0	2	1	3	0	226	926	
05:15:00 PM	7	5	0	0	7	11	4	0	25	0	10	0	2	1	6	0	219	927	
05:20:00 PM	4	5	0	0	5	11	4	0	20	4	6	0	0	4	6	0	218	913	
05:25:00 PM	8	14	1	0	5	9	10	0	21	0	7	0	0	4	8	0	234	924	
05:30:00 PM	0	9	0	0	7	11	5	0	20	0	18	0	3	1	3	0	233	922	
05:35:00 PM	3	7	0	0	6	11	2	0	18	2	10	0	0	2	7	0	232	913	
05:40:00 PM	3	6	3	0	5	14	3	0	12	2	10	0	0	1	11	0	215	895	
05:45:00 PM	3	5	0	0	2	4	6	0	24	5	8	0	1	2	4	0	202	887	
05:50:00 PM	5	4	0	0	3	11	4	0	22	4	11	0	2	1	5	0	206	875	
05:55:00 PM	2	3	0	0	6	5	8	0	42	1	15	0	0	2	6	0	226	901	

Data Provided by K-D-N.com 503-594-4224

N/S street	<b>Sequoia Pkwy</b>
E/W street	<b>S Walnut Rd</b>
City, State	Canby OR
Site Notes	
Location	45.264274 - -122.66673
Start Date	Thursday, August 23, 2018
Start Time	07:00:00 AM
Weather	
Study ID #	
<b>Peak Hour Start</b>	<b>07:15:00 AM</b>
<b>Peak 15 Min Start</b>	<b>07:15:00 AM</b>
<b>PHF (15-Min Int)</b>	<b>0.88</b>

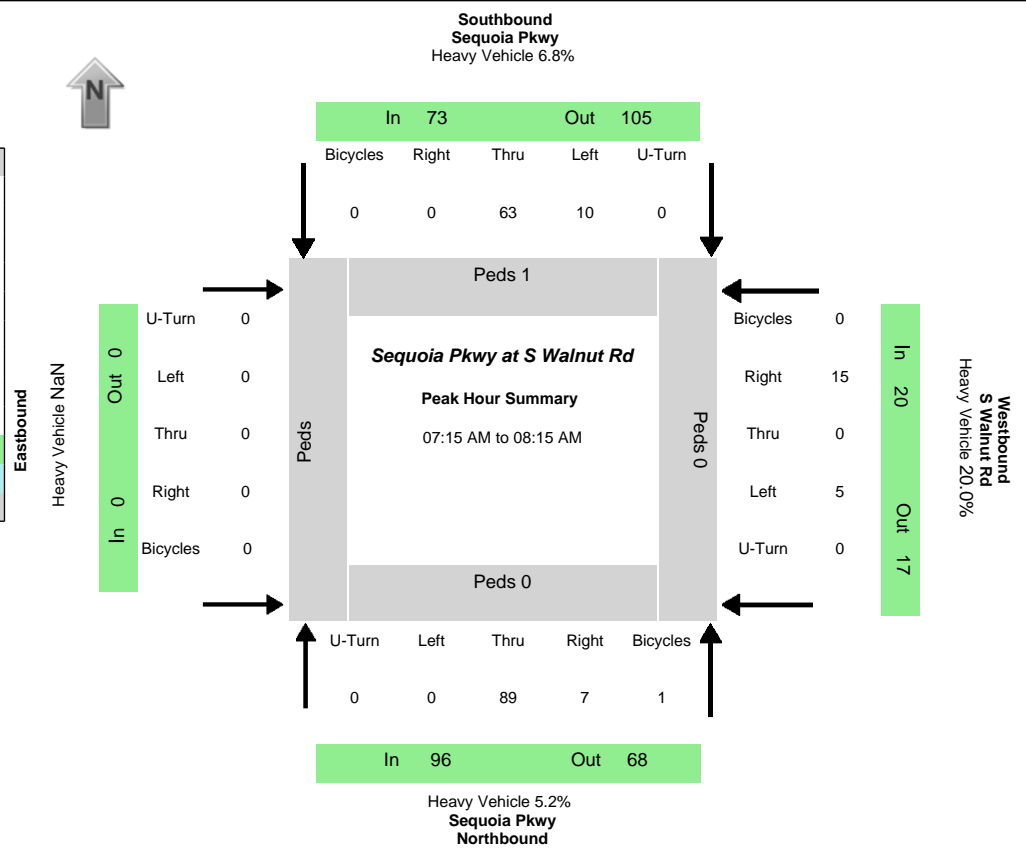

Peak-Hour Volumes (PHV)																							
Northbound				Southbound				Eastbound				Westbound				Entering				Leaving			
Left	Thru	Right	Uturn	Left	Thru	Right	Uturn	Left	Thru	Right	Uturn	Left	Thru	Right	Uturn	NB	SB	EB	WB	NB	SB	EB	WB
0	89	7	0	10	63	0	0	0	0	0	0	5	0	15	0	96	73	0	20	68	104	0	17
Percent Heavy Vehicles																							
0.0%	5.6%	0.0%	0.0%	30.0%	3.2%	0.0%	0.0%	0.0%	0.0%	0.0%	0.0%	20.0%	0.0%	20.0%	0.0%	5.2%	6.8%	NaN	20.0%	4.4%	7.7%	NaN	17.6%

PHV- Bicycles												PHV- Pedestrians									
Northbound				Southbound				Eastbound				Westbound				in Crosswalk					
Left	Thru	Right	Uturn	Left	Thru	Right	Uturn	Left	Thru	Right	Uturn	Left	Thru	Right	Uturn	Sum	NB	SB	EB	WB	Sum
1	0	0	0	0	0	0	0	0	0	0	0	0	0	0	0	1	0	1	0	0	1

Time	Northbound Sequoia Pkwy				Southbound Sequoia Pkwy				Eastbound				Westbound S Walnut Rd				15 Min Sum	1 HR Sum
	Left	Thru	Right	Uturn	Left	Thru	Right	Uturn	Left	Thru	Right	Uturn	Left	Thru	Right	Uturn		
07:00:00 AM		4	0	0	1	2	0	0					0	1	0	0		
07:05:00 AM		4	0	0	0	4	0	0					0	0	0	0		
07:10:00 AM		7	0	0	2	4	0	0					0	2	0	0		31
07:15:00 AM		7	0	0	2	3	0	0					1	1	0	0		37
07:20:00 AM		6	2	0	1	4	0	0					0	3	0	0		45
07:25:00 AM		12	1	0	1	8	0	0					2	0	0	0		54
07:30:00 AM		7	1	0	1	2	0	0					0	0	0	0		51
07:35:00 AM		11	1	0	0	2	0	0					0	2	0	0		51
07:40:00 AM		9	0	0	1	7	0	0					0	0	0	0		44
07:45:00 AM		6	0	0	0	7	0	0					2	0	0	0		48
07:50:00 AM		7	0	0	2	4	0	0					0	2	0	0		47
07:55:00 AM		6	1	0	2	5	0	0					0	5	0	0		49
08:00:00 AM		3	0	0	0	9	0	0					0	0	0	0		46
08:05:00 AM		5	0	0	0	6	0	0					0	1	0	0		43
08:10:00 AM		10	1	0	0	6	0	0					0	1	0	0		42
08:15:00 AM		4	0	0	0	5	0	0					1	2	0	0		42
08:20:00 AM		7	0	0	1	7	0	0					2	1	0	0		48
08:25:00 AM		11	1	0	1	5	0	0					0	0	0	0		48
08:30:00 AM		5	0	0	0	2	0	0					0	0	0	0		43
08:35:00 AM		2	0	0	1	3	0	0					0	1	0	0		32
08:40:00 AM		2	0	0	0	5	0	0					0	1	0	0		22
08:45:00 AM		5	1	0	0	8	0	0					1	0	0	0		30
08:50:00 AM		11	0	0	0	4	0	0					0	3	0	0		41
08:55:00 AM		5	0	0	0	3	0	0					3	0	0	0		44

Data Provided by K-D-N.com 503-594-4224

N/S street	Sequoia Pkwy
E/W street	S Walnut Rd
City, State	Canby OR
Site Notes	
Location	45.264274 - -122.66673
Start Date	Thursday, August 23, 2018
Start Time	04:00:00 PM
Weather	
Study ID #	
Peak Hour Start	04:40:00 PM
Peak 15 Min Start	05:25:00 PM
PHF (15-Min Int)	0.84

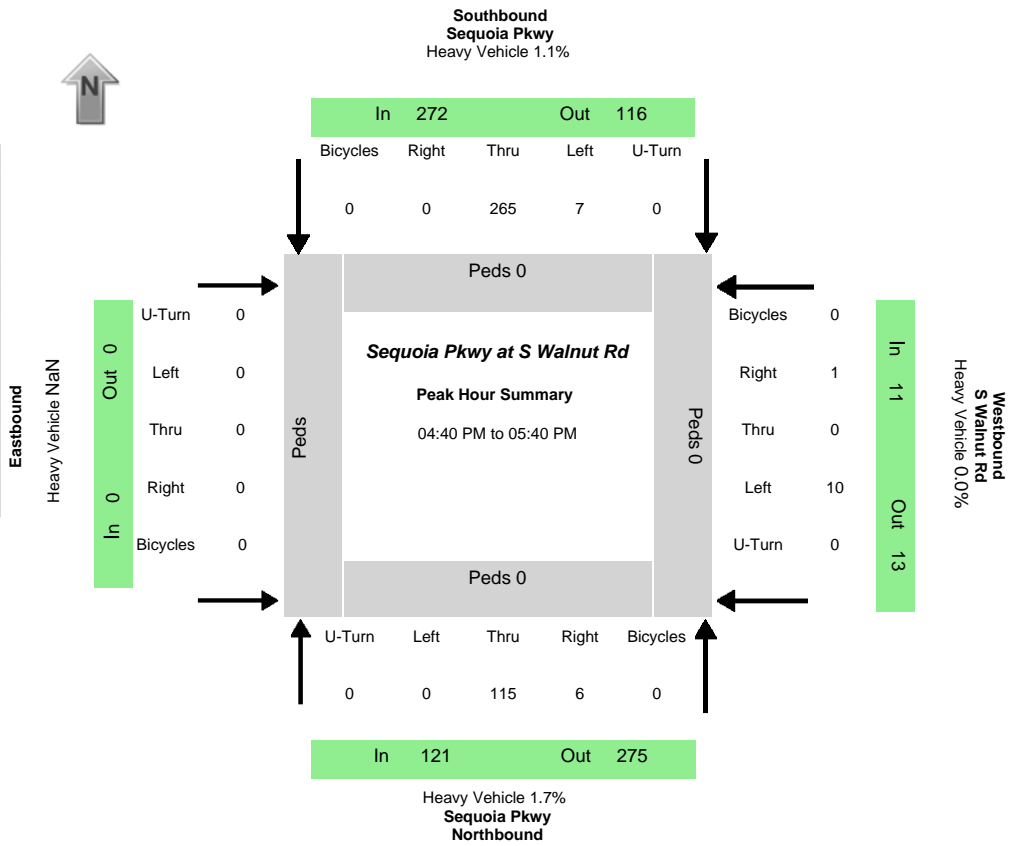

Peak-Hour Volumes (PHV)																							
Northbound				Southbound				Eastbound				Westbound				Entering				Leaving			
Left	Thru	Right	Uturn	Left	Thru	Right	Uturn	Left	Thru	Right	Uturn	Left	Thru	Right	Uturn	NB	SB	EB	WB	NB	SB	EB	WB
0	115	6	0	7	265	0	0	0	0	0	0	10	0	1	0	121	272	0	11	275	116	0	13
Percent Heavy Vehicles																							
0.0%	0.9%	16.7%	0.0%	0.0%	1.1%	0.0%	0.0%	0.0%	0.0%	0.0%	0.0%	0.0%	0.0%	0.0%	0.0%	1.7%	1.1%	NaN	0.0%	1.1%	0.9%	NaN	7.7%

PHV - Bicycles												PHV - Pedestrians									
Northbound				Southbound				Eastbound				Westbound				in Crosswalk					
Left	Thru	Right	Uturn	Left	Thru	Right	Uturn	Left	Thru	Right	Uturn	Left	Thru	Right	Uturn	Sum	NB	SB	EB	WB	Sum
0	0	0	0	0	0	0	0	0	0	0	0	0	0	0	0	0	0	0	0	0	0

Time	Northbound Sequoia Pkwy				Southbound Sequoia Pkwy				Eastbound				Westbound S Walnut Rd				15 Min Sum	1 HR Sum			
	Left	Thru	Right	Uturn	Left	Thru	Right	Uturn	Left	Thru	Right	Uturn	Left	Thru	Right	Uturn					
04:00:00 PM		14	0	0	2	18		0					1		2	0					
04:05:00 PM		11	1	0	0	21		0					0		0	0					
04:10:00 PM		7	0	0	0	14		0					1		0	0				92	
04:15:00 PM		14	0	0	0	24		0					0		2	0				95	
04:20:00 PM		8	0	0	2	19		0					0		1	0				92	
04:25:00 PM		7	0	0	1	15		0					1		1	0				95	
04:30:00 PM		10	0	0	1	12		0					1		1	0				80	
04:35:00 PM		12	3	0	0	17		0					2		0	0				84	
04:40:00 PM		9	0	0	0	22		0					0		0	0				90	
04:45:00 PM		12	0	0	1	19		0					1		0	0				98	
04:50:00 PM		9	0	0	0	18		0					0		0	0				91	
04:55:00 PM		6	0	0	0	20		0					1		0	0				87	364
05:00:00 PM		11	2	0	2	23		0					1		0	0				93	366
05:05:00 PM		8	1	0	2	25		0					0		0	0				102	369
05:10:00 PM		13	0	0	0	15		0					0		0	0				103	375
05:15:00 PM		10	0	0	0	26		0					0		1	0				101	372
05:20:00 PM		9	0	0	0	16		0					1		0	0				91	368
05:25:00 PM		16	1	0	0	19		0					0		0	0				99	379
05:30:00 PM		6	2	0	0	28		0					1		0	0				99	391
05:35:00 PM		6	0	0	2	34		0					5		0	0				120	404
05:40:00 PM		8	0	0	0	15		0					1		0	0				108	397
05:45:00 PM		10	0	0	1	17		0					1		0	0				100	393
05:50:00 PM		4	0	0	0	17		0					1		0	0				75	388
05:55:00 PM		3	1	0	0	26		0					1		1	0				83	393



Data Provided by K-D-N.com 503-594-4224

N/S street	S Walnut Rd
E/W street	SE 1st Ave
City, State	Canby OR
Site Notes	
Location	45.270232 - -122.665326
Start Date	Thursday, August 23, 2018
Start Time	07:00:00 AM
Weather	
Study ID #	
Peak Hour Start	07:15:00 AM
Peak 15 Min Start	07:35:00 AM
PHF (15-Min Int)	0.87

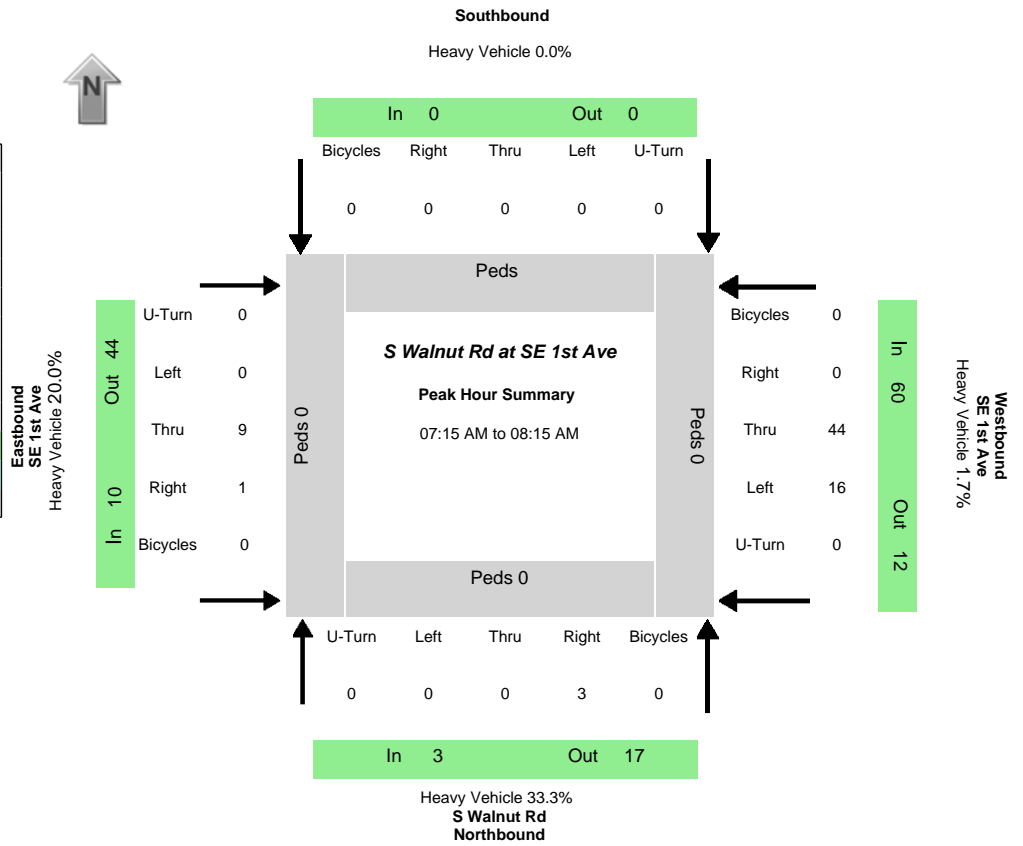

Peak-Hour Volumes (PHV)																							
Northbound				Southbound				Eastbound				Westbound				Entering				Leaving			
Left	Thru	Right	Uturn	Left	Thru	Right	Uturn	Left	Thru	Right	Uturn	Left	Thru	Right	Uturn	NB	SB	EB	WB	NB	SB	EB	WB
0	0	3	0	0	0	0	0	0	9	1	0	16	44	0	0	3	0	10	60	17	0	44	12
Percent Heavy Vehicles																							
0.0%	0.0%	33.3%	0.0%	0.0%	0.0%	0.0%	0.0%	0.0%	11.1%	100.0%	0.0%	0.0%	2.3%	0.0%	0.0%	33.3%	0.0%	20.0%	1.7%	5.9%	0.0%	2.3%	16.7%

PHV- Bicycles												PHV- Pedestrians									
Northbound				Southbound				Eastbound				Westbound				in Crosswalk					
Left	Thru	Right	Uturn	Left	Thru	Right	Uturn	Left	Thru	Right	Uturn	Left	Thru	Right	Uturn	Sum	NB	SB	EB	WB	Sum
0		0	0					0	0	0	0	0	0	0	0	0	0	0	0	0	0

Time	Northbound S Walnut Rd				Southbound				Eastbound SE 1st Ave				Westbound SE 1st Ave				15 Min Sum	1 HR Sum			
	Left	Thru	Right	Uturn	Left	Thru	Right	Uturn	Left	Thru	Right	Uturn	Left	Thru	Right	Uturn					
07:00:00 AM	0		0	0					0	0	0	0	0	2		0					
07:05:00 AM	0		0	0					0	0	0	0	0	1		0					
07:10:00 AM	0		0	0					1	0	0	0	0	3		0					7
07:15:00 AM	0		0	0					0	1	0	0	2	2		0					10
07:20:00 AM	0		0	0					1	0	0	0	2	4		0					16
07:25:00 AM	0		0	0					1	0	0	0	1	6		0					20
07:30:00 AM	0		1	0					0	0	0	0	0	4		0					20
07:35:00 AM	0		1	0					0	0	0	0	2	2		0					18
07:40:00 AM	0		0	0					3	0	0	0	1	2		0					16
07:45:00 AM	0		0	0					1	0	0	0	2	7		0					21
07:50:00 AM	0		0	0					1	0	0	0	2	2		0					21
07:55:00 AM	0		0	0					0	0	0	0	2	4		0					21
08:00:00 AM	0		1	0					0	0	0	0	0	3		0					15
08:05:00 AM	0		0	0					2	0	0	0	1	3		0					16
08:10:00 AM	0		0	0					0	0	0	0	1	5		0					16
08:15:00 AM	0		0	0					2	0	0	0	0	1		0					15
08:20:00 AM	0		0	0					1	1	0	0	1	4		0					16
08:25:00 AM	1		1	0					2	0	0	0	0	4		0					18
08:30:00 AM	0		0	0					2	0	0	0	1	1		0					19
08:35:00 AM	0		0	0					3	0	0	0	2	3		0					20
08:40:00 AM	0		1	0					1	0	0	0	0	1		0					15
08:45:00 AM	0		0	0					0	0	0	0	1	2		0					14
08:50:00 AM	0		0	0					2	0	0	0	1	3		0					12
08:55:00 AM	0		0	0					1	0	0	0	0	4		0					14

Data Provided by K-D-N.com 503-594-4224

N/S street	S Walnut Rd
E/W street	SE 1st Ave
City, State	Canby OR
Site Notes	
Location	45.270232 - -122.665326
Start Date	Thursday, August 23, 2018
Start Time	04:00:00 PM
Weather	
Study ID #	
Peak Hour Start	04:25:00 PM
Peak 15 Min Start	04:30:00 PM
PHF (15-Min Int)	0.86

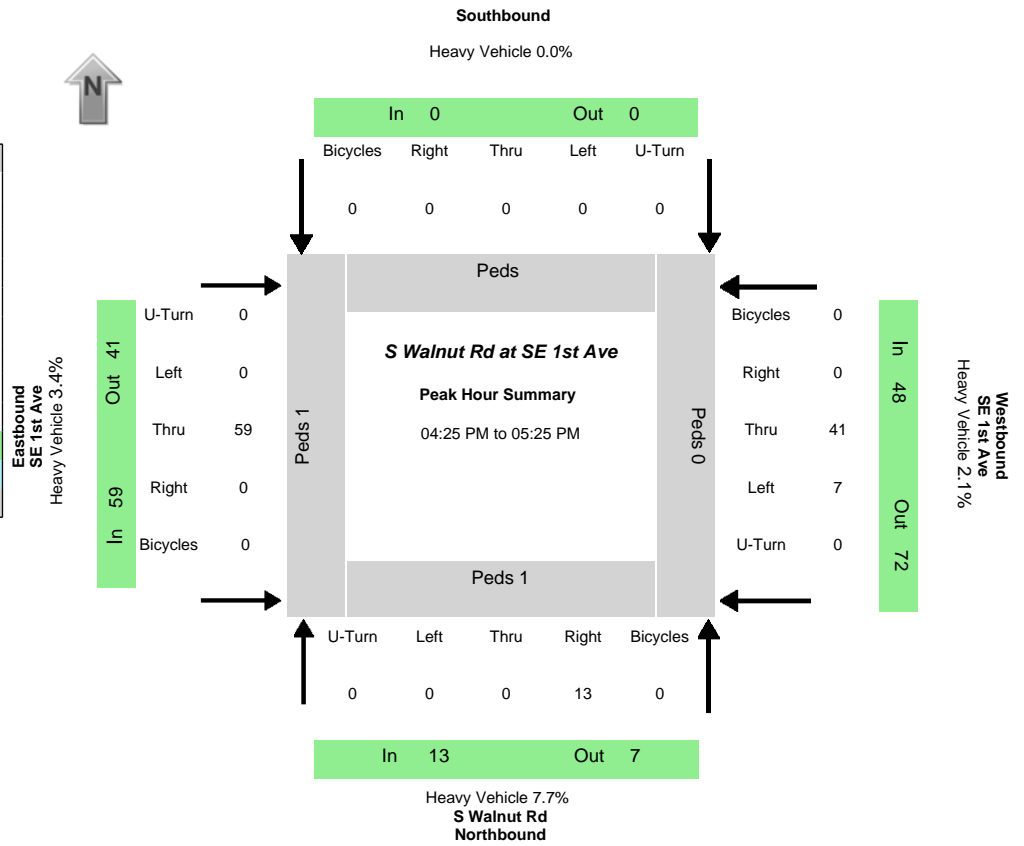

Peak-Hour Volumes (PHV)																							
Northbound				Southbound				Eastbound				Westbound				Entering				Leaving			
Left	Thru	Right	Uturn	Left	Thru	Right	Uturn	Left	Thru	Right	Uturn	Left	Thru	Right	Uturn	NB	SB	EB	WB	NB	SB	EB	WB
0	0	13	0	0	0	0	0	0	59	0	0	7	41	0	0	13	0	59	48	7	0	41	72
Percent Heavy Vehicles																							
0.0%	0.0%	7.7%	0.0%	0.0%	0.0%	0.0%	0.0%	0.0%	3.4%	0.0%	0.0%	14.3%	0.0%	0.0%	0.0%	7.7%	0.0%	3.4%	2.1%	14.3%	0.0%	0.0%	4.2%

PHV- Bicycles												PHV- Pedestrians									
Northbound				Southbound				Eastbound				Westbound				in Crosswalk					
Left	Thru	Right	Uturn	Left	Thru	Right	Uturn	Left	Thru	Right	Uturn	Left	Thru	Right	Uturn	Sum	NB	SB	EB	WB	Sum
0		0	0					0	0	0	0	0	0	0	0	0	1	0	0	0	2

Time	Northbound S Walnut Rd				Southbound				Eastbound SE 1st Ave				Westbound SE 1st Ave				15 Min Sum	1 HR Sum
	Left	Thru	Right	Uturn	Left	Thru	Right	Uturn	Left	Thru	Right	Uturn	Left	Thru	Right	Uturn		
04:00:00 PM	0		2	0					3	0	0	0	1	7		0		
04:05:00 PM	0		1	0					2	0	0	0	0	3		0		
04:10:00 PM	0		1	0					0	0	0	0	1	6		0		27
04:15:00 PM	0		0	0					6	0	0	0	0	1		0		21
04:20:00 PM	0		1	0					6	0	0	0	1	2		0		25
04:25:00 PM	0		0	0					5	0	0	0	0	3		0		25
04:30:00 PM	0		1	0					1	0	0	0	1	4		0		25
04:35:00 PM	0		2	0					4	0	0	0	1	3		0		25
04:40:00 PM	0		0	0					13	0	0	0	0	5		0		35
04:45:00 PM	0		1	0					0	0	0	0	1	1		0		31
04:50:00 PM	0		0	0					5	0	0	0	0	6		0		32
04:55:00 PM	0		0	0					4	0	0	0	2	4		0		24
05:00:00 PM	0		3	0					6	0	0	0	1	1		0		32
05:05:00 PM	0		2	0					9	0	0	0	0	1		0		33
05:10:00 PM	0		3	0					3	0	0	0	0	5		0		34
05:15:00 PM	0		1	0					4	0	0	0	0	2		0		30
05:20:00 PM	0		0	0					5	0	0	0	1	6		0		30
05:25:00 PM	0		1	0					1	0	0	0	0	1		0		22
05:30:00 PM	0		1	0					2	1	0	0	1	0		0		20
05:35:00 PM	0		1	0					5	0	0	0	3	2		0		19
05:40:00 PM	0		0	0					1	0	0	0	1	2		0		20
05:45:00 PM	0		1	0					6	0	0	0	0	5		0		27
05:50:00 PM	0		0	0					3	0	0	0	1	3		0		23
05:55:00 PM	0		0	0					3	0	0	0	0	0		0		22

Data Provided by K-D-N.com 503-594-4224

N/S street	<b>S Mulino Rd</b>
E/W street	<b>SE 1st Ave</b>
City, State	Canby OR
Site Notes	
Location	45.270684 - -122.661902
Start Date	Thursday, August 23, 2018
Start Time	07:00:00 AM
Weather	
Study ID #	
<b>Peak Hour Start</b>	<b>07:15:00 AM</b>
<b>Peak 15 Min Start</b>	<b>07:20:00 AM</b>
<b>PHF (15-Min Int)</b>	<b>0.82</b>

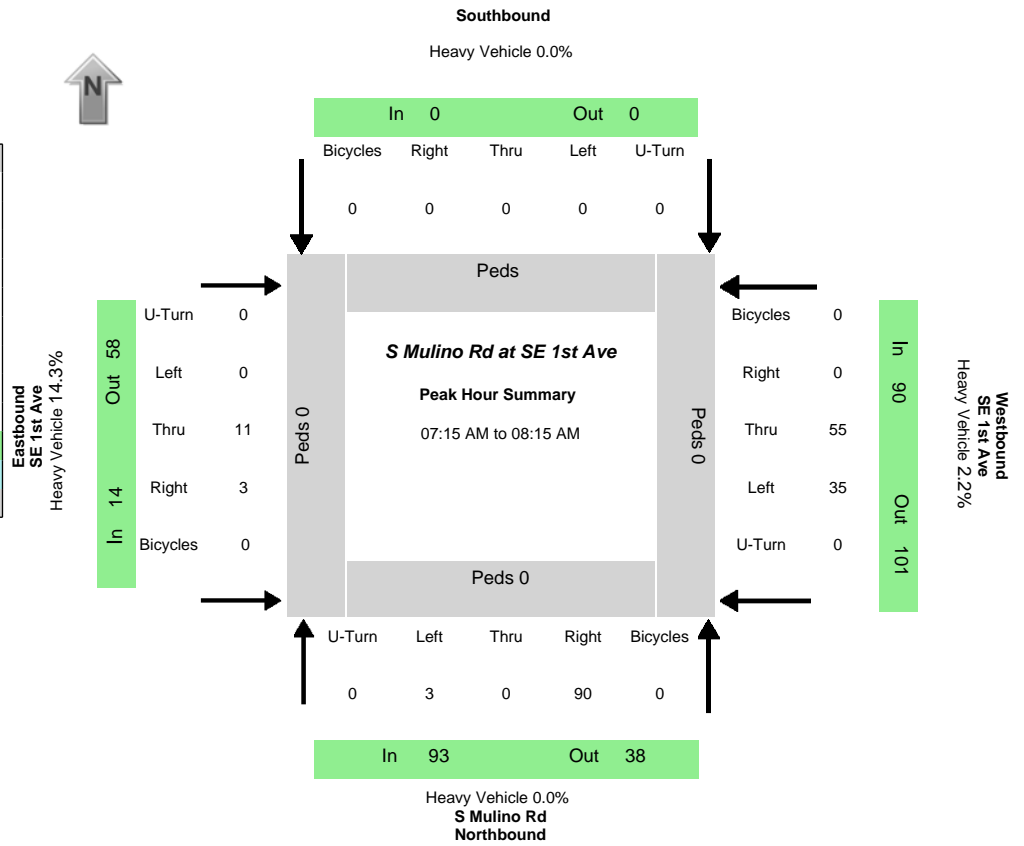

Peak-Hour Volumes (PHV)																							
Northbound				Southbound				Eastbound				Westbound				Entering				Leaving			
Left	Thru	Right	Uturn	Left	Thru	Right	Uturn	Left	Thru	Right	Uturn	Left	Thru	Right	Uturn	NB	SB	EB	WB	NB	SB	EB	WB
3	0	90	0	0	0	0	0	0	11	3	0	35	55	0	0	93	0	14	90	38	0	58	101
Percent Heavy Vehicles																							
0.0%	0.0%	0.0%	0.0%	0.0%	0.0%	0.0%	0.0%	0.0%	18.2%	0.0%	0.0%	0.0%	3.6%	0.0%	0.0%	0.0%	0.0%	14.3%	2.2%	0.0%	0.0%	3.4%	2.0%

PHV- Bicycles												PHV- Pedestrians									
Northbound				Southbound				Eastbound				Westbound				in Crosswalk					
Left	Thru	Right	Uturn	Left	Thru	Right	Uturn	Left	Thru	Right	Uturn	Left	Thru	Right	Uturn	Sum	NB	SB	EB	WB	Sum
0		0	0					0	0	0	0	0	0	0	0	0	0	0	0	0	0

All Vehicle Volumes																		
Time	Northbound S Mulino Rd				Southbound				Eastbound SE 1st Ave				Westbound SE 1st Ave				15 Min Sum	1 HR Sum
	Left	Thru	Right	Uturn	Left	Thru	Right	Uturn	Left	Thru	Right	Uturn	Left	Thru	Right	Uturn		
07:00:00 AM	0		14	0					0	0	0	0	2	0	0	0		
07:05:00 AM	1		6	0					0	0	0	0	2	1	0	0		
07:10:00 AM	1		11	0					1	0	0	0	0	2	0	0	41	
07:15:00 AM	0		4	0					0	0	0	0	2	4	0	0	35	
07:20:00 AM	0		14	0					1	0	0	0	4	7	0	0	51	
07:25:00 AM	1		13	0					1	0	0	0	2	6	0	0	59	
07:30:00 AM	0		7	0					1	0	0	0	0	3	0	0	60	
07:35:00 AM	0		12	0					2	0	0	0	2	4	0	0	54	
07:40:00 AM	0		8	0					1	2	0	0	5	4	0	0	51	
07:45:00 AM	0		4	0					2	0	0	0	2	7	0	0	55	
07:50:00 AM	1		6	0					1	0	0	0	3	4	0	0	50	
07:55:00 AM	0		3	0					0	0	0	0	2	5	0	0	40	191
08:00:00 AM	1		2	0					1	0	0	0	7	2	0	0	38	188
08:05:00 AM	0		9	0					1	1	0	0	2	4	0	0	40	195
08:10:00 AM	0		8	0					0	0	0	0	4	5	0	0	47	197
08:15:00 AM	0		3	0					1	0	0	0	4	2	0	0	44	197
08:20:00 AM	0		4	0					2	0	0	0	5	4	0	0	42	186
08:25:00 AM	0		5	0					2	1	0	0	1	5	0	0	39	177
08:30:00 AM	0		5	0					1	1	0	0	1	2	0	0	39	176
08:35:00 AM	0		2	0					2	0	0	0	3	6	0	0	37	169
08:40:00 AM	0		13	0					3	0	0	0	0	2	0	0	41	167
08:45:00 AM	0		7	0					0	0	0	0	1	3	0	0	42	163
08:50:00 AM	0		4	0					1	0	0	0	3	4	0	0	41	160
08:55:00 AM	2		6	0					1	1	0	0	1	2	0	0	36	163

Data Provided by K-D-N.com 503-594-4224	
N/S street	S Mulino Rd
E/W street	SE 1st Ave
City, State	Canby OR
Site Notes	
Location	45.270684 - -122.661902
Start Date	Thursday, August 23, 2018
Start Time	04:00:00 PM
Weather	
Study ID #	
Peak Hour Start	04:40:00 PM
Peak 15 Min Start	04:55:00 PM
PHF (15-Min Int)	0.86

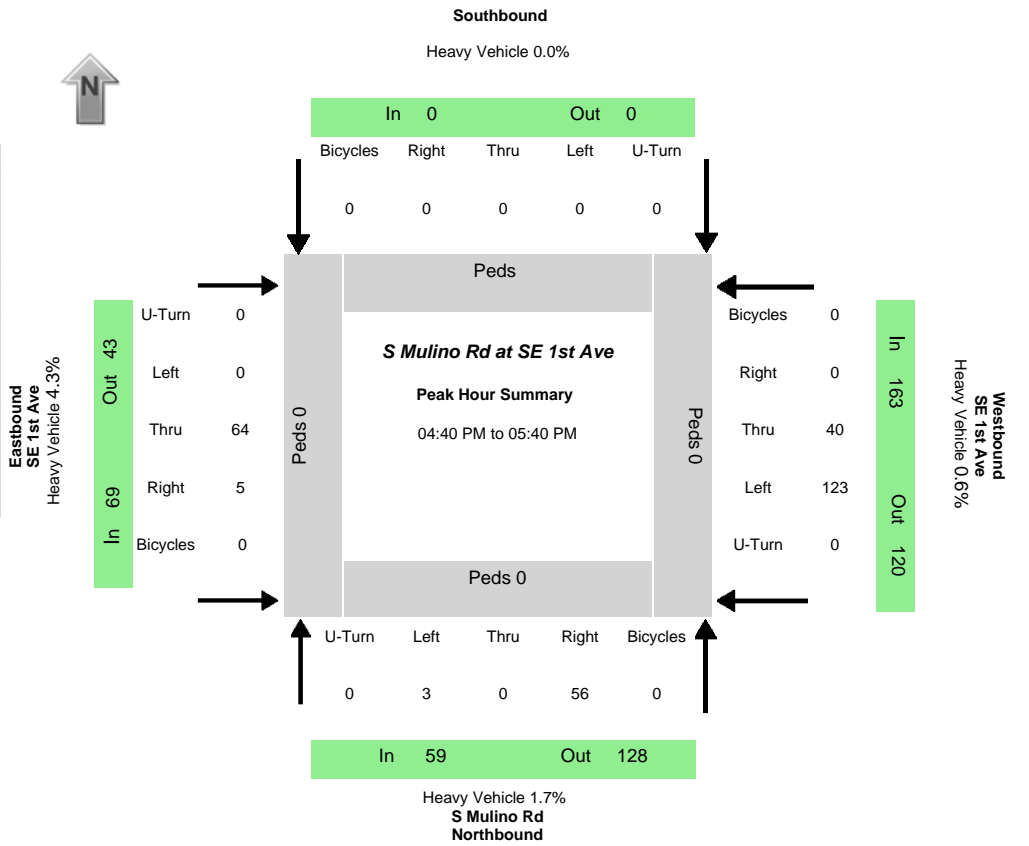

Peak-Hour Volumes (PHV)																							
Northbound				Southbound				Eastbound				Westbound				Entering				Leaving			
Left	Thru	Right	Uturn	Left	Thru	Right	Uturn	Left	Thru	Right	Uturn	Left	Thru	Right	Uturn	NB	SB	EB	WB	NB	SB	EB	WB
3	0	56	0	0	0	0	0	0	64	5	0	123	40	0	0	59	0	69	163	128	0	43	120
Percent Heavy Vehicles																							
0.0%	0.0%	1.8%	0.0%	0.0%	0.0%	0.0%	0.0%	0.0%	3.1%	20.0%	0.0%	0.0%	2.5%	0.0%	0.0%	1.7%	0.0%	4.3%	0.6%	0.8%	0.0%	2.3%	2.5%

PHV- Bicycles												PHV- Pedestrians									
Northbound				Southbound				Eastbound				Westbound				Sum	in Crosswalk				Sum
Left	Thru	Right	Uturn	Left	Thru	Right	Uturn	Left	Thru	Right	Uturn	Left	Thru	Right	Uturn		NB	SB	EB	WB	
0		0	0					0	0	0	0	0	0	0	0	0	0	0	0	0	0

All Vehicle Volumes																		
Time	Northbound S Mulino Rd				Southbound				Eastbound SE 1st Ave				Westbound SE 1st Ave				15 Min Sum	1 HR Sum
	Left	Thru	Right	Uturn	Left	Thru	Right	Uturn	Left	Thru	Right	Uturn	Left	Thru	Right	Uturn		
04:00:00 PM	1		4	0					4	0	0	0	8	7		0		
04:05:00 PM	0		4	0					4	0	0	0	8	3		0		
04:10:00 PM	0		6	0					2	1	0	0	9	8		0	69	
04:15:00 PM	0		4	0					4	2	0	0	15	0		0	70	
04:20:00 PM	0		3	0					5	0	0	0	5	3		0	67	
04:25:00 PM	0		4	0					5	0	0	0	9	4		0	63	
04:30:00 PM	2		3	0					3	0	0	0	5	4		0	55	
04:35:00 PM	1		1	0					4	0	0	0	12	1		0	58	
04:40:00 PM	0		5	0					13	1	0	0	14	5		0	74	
04:45:00 PM	0		3	0					1	0	0	0	9	1		0	71	
04:50:00 PM	1		2	0					4	2	0	0	11	5		0	77	
04:55:00 PM	0		6	0					3	0	0	0	11	6		0	65	271
05:00:00 PM	0		6	0					9	1	0	0	10	3		0	80	276
05:05:00 PM	0		7	0					9	0	0	0	13	1		0	85	287
05:10:00 PM	2		3	0					5	0	0	0	12	3		0	84	286
05:15:00 PM	0		5	0					5	1	0	0	8	5		0	79	285
05:20:00 PM	0		3	0					4	0	0	0	7	4		0	67	287
05:25:00 PM	0		3	0					3	0	0	0	11	1		0	60	283
05:30:00 PM	0		7	0					3	0	0	0	10	1		0	57	287
05:35:00 PM	0		6	0					5	0	0	0	7	5		0	62	291
05:40:00 PM	0		5	0					2	0	0	0	8	5		0	64	273
05:45:00 PM	2		2	0					5	2	0	0	13	2		0	69	285
05:50:00 PM	1		3	0					3	0	0	0	9	2		0	64	278
05:55:00 PM	0		1	0					3	0	0	0	15	2		0	65	273



Data Provided by K-D-N.com 503-594-4224

N/S street	S Haines Rd
E/W street	S Bremer Rd
City, State	Canby OR
Site Notes	
Location	45.271107 - -122.661628
Start Date	Thursday, October 04, 2018
Start Time	07:00:00 AM
Weather	
Study ID #	
Peak Hour Start	07:05:00 AM
Peak 15 Min Start	07:25:00 AM
PHF (15-Min Int)	0.89

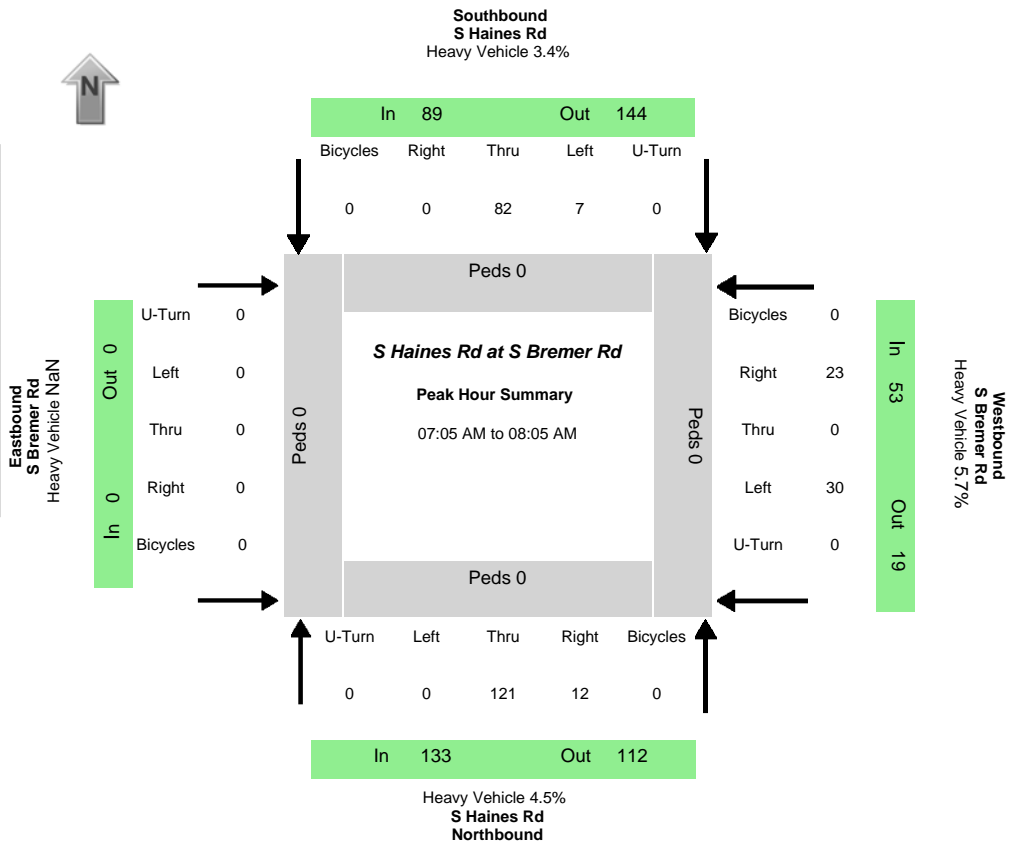

Peak-Hour Volumes (PHV)																							
Northbound				Southbound				Eastbound				Westbound				Entering				Leaving			
Left	Thru	Right	Uturn	Left	Thru	Right	Uturn	Left	Thru	Right	Uturn	Left	Thru	Right	Uturn	NB	SB	EB	WB	NB	SB	EB	WB
0	121	12	0	7	82	0	0	0	0	0	0	30	0	23	0	133	89	0	53	112	144	0	19
Percent Heavy Vehicles																							
0.0%	3.3%	16.7%	0.0%	0.0%	3.7%	0.0%	0.0%	0.0%	0.0%	0.0%	0.0%	10.0%	0.0%	0.0%	0.0%	4.5%	3.4%	NaN	5.7%	5.4%	2.8%	NaN	10.5%

PHV - Bicycles														PHV - Pedestrians							
Northbound				Southbound				Eastbound				Westbound				in Crosswalk					
Left	Thru	Right	Uturn	Left	Thru	Right	Uturn	Left	Thru	Right	Uturn	Left	Thru	Right	Uturn	Sum	NB	SB	EB	WB	Sum
0	0	0	0	0	0	0	0	0	0	0	0	0	0	0	0	0	0	0	0	0	0

Time	Northbound S Haines Rd				Southbound S Haines Rd				Eastbound S Bremer Rd				Westbound S Bremer Rd				15 Min Sum	1 HR Sum
	Left	Thru	Right	Uturn	Left	Thru	Right	Uturn	Left	Thru	Right	Uturn	Left	Thru	Right	Uturn		
07:00:00 AM	0	8	2	0	1	2	0	0	0	0	0	0	3	0	3	0		
07:05:00 AM	0	8	0	0	0	6	0	0	0	0	0	0	1	0	2	0		
07:10:00 AM	0	8	1	0	0	13	0	0	0	0	0	0	0	0	3	0	61	
07:15:00 AM	0	7	1	0	1	11	0	0	0	0	0	0	3	0	0	0	65	
07:20:00 AM	0	10	0	0	0	4	0	0	0	0	0	0	2	0	3	0	67	
07:25:00 AM	0	12	0	0	0	9	0	0	0	0	0	0	2	0	3	0	68	
07:30:00 AM	0	14	0	0	0	7	0	0	0	0	0	0	4	0	1	0	71	
07:35:00 AM	0	13	2	0	1	5	0	0	0	0	0	0	2	0	2	0	77	
07:40:00 AM	0	6	1	0	1	5	0	0	0	0	0	0	4	0	1	0	69	
07:45:00 AM	0	7	3	0	2	3	0	0	0	0	0	0	5	0	2	0	65	
07:50:00 AM	0	10	3	0	0	4	0	0	0	0	0	0	4	0	2	0	63	
07:55:00 AM	0	13	0	0	2	7	0	0	0	0	0	0	1	0	1	0	69	267
08:00:00 AM	0	13	1	0	0	8	0	0	0	0	0	0	2	0	3	0	74	275
08:05:00 AM	0	5	1	0	1	5	0	0	0	0	0	0	1	0	0	0	64	271
08:10:00 AM	0	8	2	0	1	4	0	0	0	0	0	0	0	0	0	0	55	261
08:15:00 AM	0	4	0	0	0	6	0	0	0	0	0	0	1	0	3	0	42	252
08:20:00 AM	0	6	0	0	1	2	0	0	0	0	0	0	2	0	0	0	40	244
08:25:00 AM	0	6	0	0	1	2	0	0	0	0	0	0	2	0	3	0	39	232
08:30:00 AM	0	7	2	0	1	5	0	0	0	0	0	0	1	0	0	0	41	222
08:35:00 AM	0	7	0	0	1	4	0	0	0	0	0	0	0	0	1	0	43	210
08:40:00 AM	0	2	0	0	0	5	0	0	0	0	0	0	2	0	0	0	38	201
08:45:00 AM	0	6	2	0	1	4	0	0	0	0	0	0	3	0	3	0	41	198
08:50:00 AM	0	6	0	0	0	6	0	0	0	0	0	0	1	0	0	0	41	188
08:55:00 AM	0	5	1	0	0	3	0	0	0	0	0	0	2	0	1	0	44	176

Data Provided by K-D-N.com 503-594-4224

N/S street	S Haines Rd
E/W street	S Bremer Rd
City, State	Canby OR
Site Notes	
Location	45.271107 - -122.661628
Start Date	Thursday, October 04, 2018
Start Time	04:00:00 PM
Weather	
Study ID #	
Peak Hour Start	04:00:00 PM
Peak 15 Min Start	04:00:00 PM
PHF (15-Min Int)	0.89

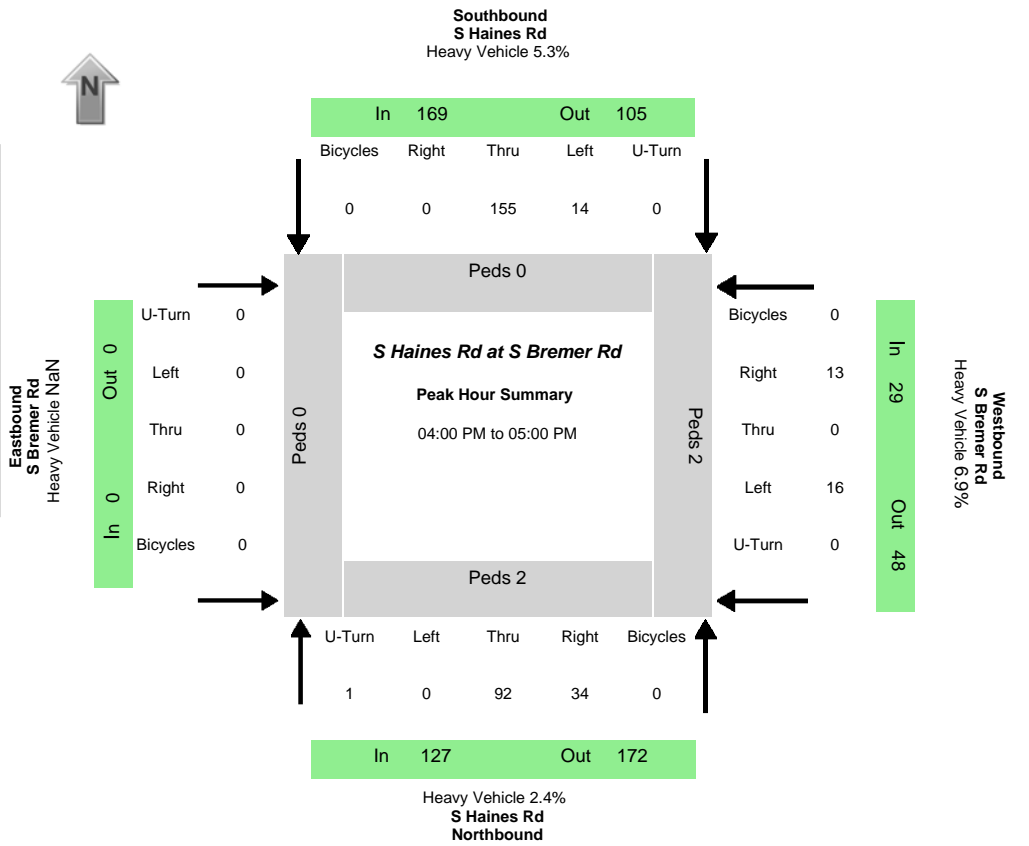

Peak-Hour Volumes (PHV)																							
Northbound				Southbound				Eastbound				Westbound				Entering				Leaving			
Left	Thru	Right	Uturn	Left	Thru	Right	Uturn	Left	Thru	Right	Uturn	Left	Thru	Right	Uturn	NB	SB	EB	WB	NB	SB	EB	WB
0	92	34	1	14	155	0	0	0	0	0	0	16	0	13	0	127	169	0	29	172	105	0	48
Percent Heavy Vehicles																							
0.0%	1.1%	5.9%	0.0%	7.1%	5.2%	0.0%	0.0%	0.0%	0.0%	0.0%	0.0%	12.5%	0.0%	0.0%	0.0%	2.4%	5.3%	NaN	6.9%	5.8%	1.0%	NaN	6.3%

PHV- Bicycles														PHV- Pedestrians							
Northbound				Southbound				Eastbound				Westbound				in Crosswalk					
Left	Thru	Right	Uturn	Left	Thru	Right	Uturn	Left	Thru	Right	Uturn	Left	Thru	Right	Uturn	Sum	NB	SB	EB	WB	Sum
0	0	0	0	0	0	0	0	0	0	0	0	0	0	0	0	0	2	0	0	2	4

Time	Northbound S Haines Rd				Southbound S Haines Rd				Eastbound S Bremer Rd				Westbound S Bremer Rd				15 Min Sum	1 HR Sum
	Left	Thru	Right	Uturn	Left	Thru	Right	Uturn	Left	Thru	Right	Uturn	Left	Thru	Right	Uturn		
04:00:00 PM	0	12	6	0	0	15	0	0	0	0	0	0	1	0	0	0		
04:05:00 PM	0	5	2	0	3	15	0	0	0	0	0	0	3	0	5	0		
04:10:00 PM	0	8	3	0	1	10	0	0	0	0	0	0	2	0	0	0	91	
04:15:00 PM	0	9	2	0	1	13	0	0	0	0	0	0	0	0	0	0	82	
04:20:00 PM	0	12	3	1	0	11	0	0	0	0	0	0	3	0	1	0	80	
04:25:00 PM	0	7	2	0	1	12	0	0	0	0	0	0	1	0	2	0	81	
04:30:00 PM	0	7	4	0	0	15	0	0	0	0	0	0	2	0	1	0	85	
04:35:00 PM	0	7	2	0	3	16	0	0	0	0	0	0	0	0	1	0	83	
04:40:00 PM	0	5	3	0	2	20	0	0	0	0	0	0	1	0	1	0	90	
04:45:00 PM	0	5	1	0	1	10	0	0	0	0	0	0	1	0	1	0	80	
04:50:00 PM	0	9	1	0	0	7	0	0	0	0	0	0	1	0	0	0	69	
04:55:00 PM	0	6	5	0	2	11	0	0	0	0	0	0	1	0	1	0	63	325
05:00:00 PM	0	7	3	0	0	10	0	0	0	0	0	0	3	0	0	0	67	314
05:05:00 PM	0	7	1	0	3	17	0	0	0	0	0	0	3	0	2	0	82	314
05:10:00 PM	0	4	3	0	0	9	0	0	0	0	0	0	0	0	0	0	72	306
05:15:00 PM	0	5	3	0	1	14	0	0	0	0	0	0	2	0	1	0	75	307
05:20:00 PM	0	6	2	0	1	15	0	0	0	0	0	0	1	0	0	0	67	301
05:25:00 PM	0	9	2	0	0	15	0	0	0	0	0	0	2	0	1	0	80	305
05:30:00 PM	0	4	5	0	3	19	0	0	0	0	0	0	1	0	1	0	87	309
05:35:00 PM	0	6	2	0	1	7	0	0	0	0	0	0	1	0	1	0	80	298
05:40:00 PM	0	9	4	0	1	6	0	0	0	0	0	0	3	0	1	0	75	290
05:45:00 PM	0	5	3	0	3	13	0	0	0	0	0	0	3	0	0	0	69	298
05:50:00 PM	0	4	3	0	1	9	0	0	0	0	0	0	0	0	0	0	68	297
05:55:00 PM	0	5	1	0	0	6	0	0	0	0	0	0	1	0	2	0	59	286

## **Tube Count Data**

---

# All Traffic Data Services

1st Ave btwn Hazeldell & Walnut

Site Code: 21984

Latitude: 0' 0.0000 Undefined

Longitude: 0' 0.0000 Undefined

EB

Start Time	Bikes	Cars & Trailer	2 Axle Long	Buses	2 Axle 6 Tire	3 Axle Single	4 Axle Single	<5 Axl Double	5 Axle Double	>6 Axl Double	<6 Axl Multi	6 Axle Multi	>6 Axl Multi	Not Classe	Total
02/19/20	0	0	0	0	0	0	0	0	0	0	0	0	0	0	0
00:15	0	1	0	0	0	0	0	0	0	0	0	0	0	0	1
00:30	0	1	0	0	0	0	0	0	0	0	0	0	0	0	1
00:45	0	0	0	0	0	0	0	0	0	0	0	0	0	0	0
	0	2	0	0	0	0	0	0	0	0	0	0	0	0	2
01:00	0	0	0	0	0	0	0	0	0	0	0	0	0	0	0
01:15	0	0	0	0	0	0	0	0	0	0	0	0	0	0	0
01:30	0	0	0	0	0	0	0	0	0	0	0	0	0	0	0
01:45	0	0	0	0	0	0	0	0	0	0	0	0	0	0	0
	0	0	0	0	0	0	0	0	0	0	0	0	0	0	0
02:00	0	0	0	0	0	0	0	0	0	0	0	0	0	0	0
02:15	0	1	0	0	0	0	0	0	0	0	0	0	0	0	1
02:30	0	0	0	0	0	0	0	0	0	0	0	0	0	0	0
02:45	0	0	0	0	0	0	0	0	0	0	0	0	0	0	0
	0	1	0	0	0	0	0	0	0	0	0	0	0	0	1
03:00	0	0	0	0	0	0	0	0	0	0	0	0	0	0	0
03:15	0	0	0	0	0	0	0	0	0	0	0	0	0	0	0
03:30	0	0	0	0	0	0	0	0	0	0	0	0	0	0	0
03:45	0	0	0	0	0	0	0	0	0	0	0	0	0	0	0
	0	0	0	0	0	0	0	0	0	0	0	0	0	0	0
04:00	0	0	0	0	0	0	0	0	0	0	0	0	0	0	0
04:15	0	0	0	0	0	0	0	0	0	0	0	0	0	0	0
04:30	0	0	0	0	0	0	0	0	0	0	0	0	0	0	0
04:45	0	0	0	0	0	0	0	0	0	0	0	0	0	0	0
	0	0	0	0	0	0	0	0	0	0	0	0	0	0	0
05:00	0	1	0	0	0	0	0	0	0	0	0	0	0	0	1
05:15	0	0	0	0	0	0	0	0	0	0	0	0	0	0	0
05:30	0	0	0	0	0	0	0	0	0	0	0	0	0	0	0
05:45	0	2	1	0	1	0	0	0	0	0	0	0	0	0	4
	0	3	1	0	1	0	0	0	0	0	0	0	0	0	5
06:00	0	0	0	0	0	0	0	0	0	0	0	0	0	0	0
06:15	0	2	1	0	1	0	0	0	0	0	0	0	0	0	4
06:30	0	1	1	0	0	0	0	0	0	0	0	0	0	0	2
06:45	0	1	1	0	2	0	0	0	0	0	0	0	0	0	4
	0	4	3	0	3	0	0	0	0	0	0	0	0	0	10
07:00	0	0	2	0	1	0	0	0	0	0	0	0	0	0	3
07:15	0	2	0	0	1	0	0	0	0	0	0	1	0	0	4
07:30	0	4	1	1	1	0	0	0	0	0	0	0	0	0	7
07:45	0	0	0	0	1	0	0	0	0	0	0	0	0	0	1
	0	6	3	1	4	0	0	0	0	0	0	1	0	0	15
08:00	0	1	1	0	0	0	0	0	0	0	0	0	0	0	2
08:15	0	0	2	1	0	0	0	0	0	0	0	0	0	0	3
08:30	0	5	1	1	3	0	0	0	0	0	0	0	0	1	11
08:45	0	3	3	1	1	0	0	0	0	0	0	0	0	0	8
	0	9	7	3	4	0	0	0	0	0	0	0	0	1	24
09:00	0	0	1	0	1	0	0	0	0	0	0	0	0	1	3
09:15	0	2	0	0	0	0	0	0	0	0	0	0	0	0	2
09:30	0	5	3	0	1	0	0	0	0	0	0	0	0	0	9
09:45	0	3	1	0	1	0	0	0	0	0	0	0	0	0	5
	0	10	5	0	3	0	0	0	0	0	0	0	0	1	19
10:00	0	4	0	0	2	0	0	0	0	0	0	0	0	0	6
10:15	1	5	0	0	2	0	0	0	0	0	0	0	0	1	9
10:30	0	4	2	0	1	0	0	1	0	0	0	0	0	0	8
10:45	0	2	0	0	5	0	0	0	0	0	0	0	0	0	7
	1	15	2	0	10	0	0	1	0	0	0	0	0	1	30
11:00	0	3	0	0	2	0	0	1	0	0	0	0	0	0	6
11:15	0	1	1	0	1	0	0	0	0	0	0	0	0	0	3
11:30	0	5	3	0	1	0	0	0	0	0	0	0	0	0	9
11:45	0	3	3	0	4	0	0	0	0	0	0	0	0	0	10
	0	12	7	0	8	0	0	1	0	0	0	0	0	0	28
Total	1	62	28	4	33	0	0	2	0	0	0	1	0	3	134
Percent	0.7%	46.3%	20.9%	3.0%	24.6%	0.0%	0.0%	1.5%	0.0%	0.0%	0.0%	0.7%	0.0%	2.2%	



# All Traffic Data Services

1st Ave btwn Hazeldell & Walnut

Site Code: 21984

Latitude: 0' 0.0000 Undefined

Longitude: 0' 0.0000 Undefined

EB

Start Time	Bikes	Cars & Trailer	2 Axle Long	Buses	2 Axle 6 Tire	3 Axle Single	4 Axle Single	<5 Axl Double	5 Axle Double	>6 Axl Double	<6 Axl Multi	6 Axle Multi	>6 Axl Multi	Not Classe	Total
12 PM	0	8	1	0	2	0	0	0	0	0	0	0	0	0	11
12:15	0	11	2	0	0	0	0	0	0	0	0	0	0	0	13
12:30	0	4	0	0	2	0	0	0	0	0	0	0	0	0	6
12:45	0	3	3	0	2	1	0	0	0	0	0	0	0	0	9
	0	26	6	0	6	1	0	0	0	0	0	0	0	0	39
13:00	0	6	1	0	1	0	0	0	0	0	0	0	0	0	8
13:15	0	5	6	0	2	0	0	0	1	0	0	0	0	0	14
13:30	0	4	1	0	1	0	0	0	0	0	0	0	0	0	6
13:45	1	11	2	0	2	1	0	0	0	0	0	0	0	0	17
	1	26	10	0	6	1	0	0	1	0	0	0	0	0	45
14:00	0	2	4	0	0	0	0	0	0	0	0	0	0	0	6
14:15	0	3	1	0	5	0	0	0	0	0	0	0	0	0	9
14:30	0	5	1	0	1	0	0	1	0	0	0	0	0	0	8
14:45	0	9	1	1	5	0	0	0	0	0	0	0	0	0	16
	0	19	7	1	11	0	0	1	0	0	0	0	0	0	39
15:00	0	1	1	1	1	0	0	0	0	0	0	0	0	0	4
15:15	0	11	0	0	4	0	0	0	0	0	0	0	0	1	16
15:30	0	3	2	0	3	0	0	0	0	0	0	0	0	0	8
15:45	0	6	6	0	4	0	0	0	0	0	0	0	0	0	16
	0	21	9	1	12	0	0	0	0	0	0	0	0	1	44
16:00	0	7	4	0	2	0	0	0	0	0	0	0	0	0	13
16:15	0	7	1	0	3	0	0	0	0	0	0	0	0	0	11
16:30	0	7	2	0	3	0	0	0	0	0	0	0	0	2	14
16:45	1	11	1	0	2	0	0	0	0	0	0	0	0	0	15
	1	32	8	0	10	0	0	0	0	0	0	0	0	2	53
17:00	0	5	2	0	5	0	0	1	0	0	0	0	0	0	13
17:15	2	8	6	0	1	0	0	0	0	0	0	0	0	0	17
17:30	0	8	2	0	2	0	0	0	0	0	0	0	0	0	12
17:45	0	5	1	0	1	0	0	0	0	0	0	0	0	0	7
	2	26	11	0	9	0	0	1	0	0	0	0	0	0	49
18:00	0	9	3	0	2	0	0	0	0	0	0	0	0	0	14
18:15	0	5	2	0	1	0	0	1	0	0	0	0	0	0	9
18:30	0	5	3	0	2	0	0	0	0	0	0	0	0	0	10
18:45	0	4	2	0	4	0	0	0	0	0	0	0	0	0	10
	0	23	10	0	9	0	0	1	0	0	0	0	0	0	43
19:00	0	3	4	0	2	0	0	0	0	0	0	0	0	0	9
19:15	0	3	3	0	2	0	0	0	0	0	0	0	0	0	8
19:30	0	1	1	0	2	0	0	0	0	0	0	0	0	0	4
19:45	0	4	0	0	1	0	0	0	0	0	0	0	0	0	5
	0	11	8	0	7	0	0	0	0	0	0	0	0	0	26
20:00	0	8	4	0	0	0	0	0	0	0	0	0	0	1	13
20:15	1	1	1	0	1	0	0	0	0	0	0	0	0	1	5
20:30	0	5	2	0	0	0	0	0	0	0	0	0	0	0	7
20:45	0	2	1	0	0	0	0	0	0	0	0	0	0	0	3
	1	16	8	0	1	0	0	0	0	0	0	0	0	2	28
21:00	0	3	1	0	0	0	0	0	0	0	0	0	0	0	4
21:15	0	3	1	0	0	0	0	0	0	0	0	0	0	0	4
21:30	0	1	1	0	0	0	0	0	0	0	0	0	0	0	2
21:45	0	0	0	0	0	0	0	0	0	0	0	0	0	0	0
	0	7	3	0	0	0	0	0	0	0	0	0	0	0	10
22:00	0	0	0	0	0	0	0	0	0	0	0	0	0	0	0
22:15	0	3	0	0	0	0	0	0	0	0	0	0	0	0	3
22:30	0	1	0	0	2	0	0	0	0	0	0	0	0	0	3
22:45	0	1	1	0	0	0	0	0	0	0	0	0	0	0	2
	0	5	1	0	2	0	0	0	0	0	0	0	0	0	8
23:00	0	0	1	0	0	1	0	0	0	0	0	0	0	0	2
23:15	0	2	1	0	0	0	0	0	0	0	0	0	0	0	3
23:30	0	2	1	0	0	0	0	0	0	0	0	0	0	0	3
23:45	0	0	0	0	0	0	0	0	0	0	0	0	0	0	0
	0	4	3	0	0	1	0	0	0	0	0	0	0	0	8
Total	5	216	84	2	73	3	0	3	1	0	0	0	0	5	392
Percent	1.3%	55.1%	21.4%	0.5%	18.6%	0.8%	0.0%	0.8%	0.3%	0.0%	0.0%	0.0%	0.0%	1.3%	
Grand Total	6	278	112	6	106	3	0	5	1	0	0	1	0	8	526
Percent	1.1%	52.9%	21.3%	1.1%	20.2%	0.6%	0.0%	1.0%	0.2%	0.0%	0.0%	0.2%	0.0%	1.5%	

# All Traffic Data Services

1st Ave btwn Hazeldell & Walnut

Site Code: 21984

Latitude: 0' 0.0000 Undefined

Longitude: 0' 0.0000 Undefined

WB

Start Time	Bikes	Cars & Trailer	2 Axle Long	Buses	2 Axle 6 Tire	3 Axle Single	4 Axle Single	<5 Axl Double	5 Axle Double	>6 Axl Double	<6 Axl Multi	6 Axle Multi	>6 Axl Multi	Not Classe	Total
02/19/20	0	0	0	0	0	0	0	0	0	0	0	0	0	0	0
00:15	0	0	0	0	0	0	0	0	0	0	0	0	0	0	0
00:30	0	0	0	0	0	0	0	0	0	0	0	0	0	0	0
00:45	0	0	0	0	0	0	0	0	0	0	0	0	0	0	0
01:00	0	0	0	0	0	0	0	0	0	0	0	0	0	0	0
01:15	0	0	0	0	0	0	0	0	0	0	0	0	0	0	0
01:30	0	0	0	0	0	0	0	0	0	0	0	0	0	0	0
01:45	0	0	0	0	0	0	0	0	0	0	0	0	0	0	0
02:00	0	0	0	0	0	0	0	0	0	0	0	0	0	0	0
02:15	0	0	0	0	0	0	0	0	0	0	0	0	0	0	0
02:30	0	0	0	0	0	0	0	0	0	0	0	0	0	0	0
02:45	0	0	0	0	0	0	0	0	0	0	0	0	0	0	0
03:00	0	0	0	0	0	0	0	0	0	0	0	0	0	0	0
03:15	0	0	0	0	0	0	0	0	0	0	0	0	0	0	0
03:30	0	0	0	0	0	0	0	0	0	0	0	0	0	0	0
03:45	0	0	0	0	0	0	0	0	0	0	0	0	0	0	0
04:00	0	1	0	0	0	0	0	0	0	0	0	0	0	0	1
04:15	0	0	0	0	0	0	0	0	0	0	0	0	0	0	0
04:30	0	0	1	0	0	0	0	0	0	0	0	0	0	0	1
04:45	0	1	1	0	0	0	0	0	0	0	0	0	0	0	2
05:00	0	2	2	0	0	0	0	0	0	0	0	0	0	0	4
05:15	0	2	0	0	1	0	0	0	0	0	0	0	0	0	3
05:30	0	1	1	0	0	0	0	0	0	0	0	0	0	0	2
05:45	0	1	0	0	2	0	0	0	0	0	0	0	0	0	3
06:00	0	4	0	0	0	0	0	0	0	0	0	0	0	0	4
06:15	0	8	1	0	3	0	0	0	0	0	0	0	0	0	12
06:30	0	3	1	0	0	0	0	0	0	0	0	0	0	0	4
06:45	0	2	2	0	0	0	0	0	0	0	0	0	0	0	4
07:00	0	5	1	0	0	0	0	0	0	0	0	0	0	0	6
07:15	0	8	0	0	1	0	0	0	0	0	0	0	0	0	9
07:30	0	18	4	0	1	0	0	0	0	0	0	0	0	0	23
07:45	0	2	2	0	0	0	0	0	0	0	0	0	0	0	4
08:00	0	2	4	0	1	0	0	0	0	0	0	0	0	0	7
08:15	0	7	3	0	1	0	0	0	0	0	0	0	0	0	11
08:30	0	8	3	0	1	0	0	0	0	0	0	0	0	0	12
08:45	0	19	12	0	3	0	0	0	0	0	0	0	0	0	34
09:00	0	4	5	0	2	0	0	0	0	0	0	0	0	0	11
09:15	0	8	2	0	2	0	0	0	0	0	0	0	0	0	12
09:30	0	7	1	0	1	0	0	0	0	0	0	0	0	0	9
09:45	0	3	0	0	2	0	0	0	0	0	0	0	0	0	5
10:00	0	22	8	0	7	0	0	0	0	0	0	0	0	0	37
10:15	0	2	1	0	1	0	0	0	0	0	0	0	0	0	4
10:30	0	6	1	1	1	0	0	0	0	0	0	0	0	0	9
10:45	0	2	1	0	0	0	0	0	0	0	0	0	0	0	3
11:00	0	2	1	1	1	0	0	1	0	0	0	0	0	0	6
11:15	0	12	4	2	3	0	0	1	0	0	0	0	0	0	22
11:30	0	5	3	0	3	0	0	0	0	0	0	0	0	0	11
11:45	0	6	2	0	1	0	0	0	0	0	0	0	0	0	9
12:00	0	7	1	0	1	0	0	1	0	0	0	0	0	0	10
12:15	0	3	2	0	3	0	0	0	0	0	0	0	0	0	8
12:30	0	21	8	0	8	0	0	1	0	0	0	0	0	0	38
12:45	0	4	1	0	3	0	0	0	0	0	0	0	0	0	8
13:00	0	2	1	0	1	0	0	0	0	0	0	0	0	0	4
13:15	2	8	1	0	2	0	0	0	0	0	0	0	0	0	13
13:30	0	5	4	0	0	0	0	0	0	0	0	0	0	0	9
13:45	0	19	7	0	6	0	0	0	0	0	0	0	0	0	34
<b>Total</b>	<b>2</b>	<b>121</b>	<b>46</b>	<b>2</b>	<b>31</b>	<b>0</b>	<b>0</b>	<b>2</b>	<b>0</b>	<b>0</b>	<b>0</b>	<b>0</b>	<b>0</b>	<b>0</b>	<b>204</b>
<b>Percent</b>	<b>1.0%</b>	<b>59.3%</b>	<b>22.5%</b>	<b>1.0%</b>	<b>15.2%</b>	<b>0.0%</b>	<b>0.0%</b>	<b>1.0%</b>	<b>0.0%</b>	<b>0.0%</b>	<b>0.0%</b>	<b>0.0%</b>	<b>0.0%</b>	<b>0.0%</b>	

# All Traffic Data Services

1st Ave btwn Hazeldell & Walnut

Site Code: 21984

Latitude: 0' 0.0000 Undefined

Longitude: 0' 0.0000 Undefined

WB

Start Time	Bikes	Cars & Trailer	2 Axle Long	Buses	2 Axle 6 Tire	3 Axle Single	4 Axle Single	<5 Axl Double	5 Axle Double	>6 Axl Double	<6 Axl Multi	6 Axle Multi	>6 Axl Multi	Not Classe	Total
12 PM	0	3	4	0	3	0	0	0	0	0	0	0	0	0	10
12:15	0	3	3	0	1	0	0	0	0	0	0	0	0	0	7
12:30	0	4	1	0	3	0	0	0	0	0	0	0	0	0	8
12:45	0	9	0	1	0	1	0	0	1	0	0	0	0	0	12
	0	19	8	1	7	1	0	0	1	0	0	0	0	0	37
13:00	1	3	4	0	1	1	0	0	0	0	0	0	0	0	10
13:15	1	5	4	0	2	0	0	0	0	0	0	0	0	0	12
13:30	0	4	3	0	1	0	0	0	0	0	0	0	0	0	8
13:45	0	6	3	0	1	0	0	0	0	0	0	0	0	0	10
	2	18	14	0	5	1	0	0	0	0	0	0	0	0	40
14:00	0	7	2	0	2	0	0	0	0	0	0	0	0	0	11
14:15	0	5	4	1	2	0	0	0	0	0	0	0	0	0	12
14:30	0	6	2	0	0	0	0	0	0	0	0	0	0	0	8
14:45	0	3	6	0	5	0	0	0	0	0	0	0	0	0	14
	0	21	14	1	9	0	0	0	0	0	0	0	0	0	45
15:00	0	7	2	0	0	0	0	0	0	0	0	0	0	0	9
15:15	0	3	3	0	1	0	0	0	0	0	0	0	0	0	7
15:30	0	8	2	0	1	0	0	0	0	0	0	0	0	0	11
15:45	0	4	1	0	2	0	0	0	0	0	0	0	0	0	7
	0	22	8	0	4	0	0	0	0	0	0	0	0	0	34
16:00	0	10	4	2	1	0	0	0	0	0	0	0	0	0	17
16:15	0	7	1	1	0	0	0	0	0	0	0	0	0	0	9
16:30	1	12	3	0	1	0	0	0	0	0	0	0	0	0	17
16:45	1	8	3	0	1	0	0	0	0	0	0	0	0	0	13
	2	37	11	3	3	0	0	0	0	0	0	0	0	0	56
17:00	0	3	2	0	2	0	0	0	0	0	0	0	0	0	7
17:15	0	5	5	0	1	0	0	1	0	0	0	0	0	0	12
17:30	0	7	2	0	0	0	0	0	0	0	0	0	0	0	9
17:45	0	3	3	0	0	0	0	1	0	0	0	0	0	0	7
	0	18	12	0	3	0	0	2	0	0	0	0	0	0	35
18:00	0	5	3	0	2	0	0	0	0	0	0	0	0	0	10
18:15	0	4	2	0	3	0	0	0	0	0	0	0	0	0	9
18:30	0	3	1	0	3	0	0	0	0	0	0	0	0	0	7
18:45	0	3	2	0	0	0	0	0	0	0	0	0	0	0	5
	0	15	8	0	8	0	0	0	0	0	0	0	0	0	31
19:00	0	0	1	0	0	0	0	0	0	0	0	0	0	0	1
19:15	0	2	1	0	0	0	0	0	0	0	0	0	0	0	3
19:30	0	2	0	0	0	0	0	0	0	0	0	0	0	0	2
19:45	0	7	0	0	1	0	0	0	0	0	0	0	0	0	8
	0	11	2	0	1	0	0	0	0	0	0	0	0	0	14
20:00	0	3	0	0	0	0	0	0	0	0	0	0	0	0	3
20:15	0	0	0	0	0	0	0	0	0	0	0	0	0	0	0
20:30	0	2	0	0	0	0	0	0	0	0	0	0	0	0	2
20:45	0	1	1	0	0	0	0	0	0	0	0	0	0	0	2
	0	6	1	0	0	0	0	0	0	0	0	0	0	0	7
21:00	0	2	2	0	0	0	0	0	0	0	0	0	0	0	4
21:15	0	0	0	0	0	0	0	0	0	0	0	0	0	0	0
21:30	0	1	0	0	1	0	0	0	0	0	0	0	0	0	2
21:45	0	1	1	0	0	0	0	0	0	0	0	0	0	0	2
	0	4	3	0	1	0	0	0	0	0	0	0	0	0	8
22:00	0	2	0	0	0	0	0	0	0	0	0	0	0	0	2
22:15	0	0	0	0	0	0	0	0	0	0	0	0	0	0	0
22:30	0	0	0	0	0	0	0	0	0	0	0	0	0	0	0
22:45	0	0	1	0	0	0	0	0	0	0	0	0	0	0	1
	0	2	1	0	0	0	0	0	0	0	0	0	0	0	3
23:00	0	1	0	0	0	0	0	0	0	0	0	0	0	0	1
23:15	0	1	0	0	0	0	0	0	0	0	0	0	0	0	1
23:30	0	0	0	0	0	0	0	0	0	0	0	0	0	0	0
23:45	0	3	0	0	0	0	0	0	0	0	0	0	0	0	3
	0	5	0	0	0	0	0	0	0	0	0	0	0	0	5
Total	4	178	82	5	41	2	0	2	1	0	0	0	0	0	315
Percent	1.3%	56.5%	26.0%	1.6%	13.0%	0.6%	0.0%	0.6%	0.3%	0.0%	0.0%	0.0%	0.0%	0.0%	
Grand Total	6	299	128	7	72	2	0	4	1	0	0	0	0	0	519
Percent	1.2%	57.6%	24.7%	1.3%	13.9%	0.4%	0.0%	0.8%	0.2%	0.0%	0.0%	0.0%	0.0%	0.0%	

### All Traffic Data Services

1st Ave btwn Hazeldell & Walnut

Site Code: 21984

Latitude: 0' 0.0000 Undefined

Longitude: 0' 0.0000 Undefined

EB, WB

Start Time	Bikes	Cars & Trailer	2 Axle Long	Buses	2 Axle 6 Tire	3 Axle Single	4 Axle Single	<5 Axl Double	5 Axle Double	>6 Axl Double	<6 Axl Multi	6 Axle Multi	>6 Axl Multi	Not Classe	Total
02/19/20	0	0	0	0	0	0	0	0	0	0	0	0	0	0	0
00:15	0	1	0	0	0	0	0	0	0	0	0	0	0	0	1
00:30	0	1	0	0	0	0	0	0	0	0	0	0	0	0	1
00:45	0	0	0	0	0	0	0	0	0	0	0	0	0	0	0
01:00	0	2	0	0	0	0	0	0	0	0	0	0	0	0	2
01:15	0	0	0	0	0	0	0	0	0	0	0	0	0	0	0
01:30	0	0	0	0	0	0	0	0	0	0	0	0	0	0	0
01:45	0	0	0	0	0	0	0	0	0	0	0	0	0	0	0
02:00	0	0	0	0	0	0	0	0	0	0	0	0	0	0	0
02:15	0	1	0	0	0	0	0	0	0	0	0	0	0	0	1
02:30	0	0	0	0	0	0	0	0	0	0	0	0	0	0	0
02:45	0	0	0	0	0	0	0	0	0	0	0	0	0	0	0
03:00	0	1	0	0	0	0	0	0	0	0	0	0	0	0	1
03:15	0	0	0	0	0	0	0	0	0	0	0	0	0	0	0
03:30	0	0	0	0	0	0	0	0	0	0	0	0	0	0	0
03:45	0	0	0	0	0	0	0	0	0	0	0	0	0	0	0
04:00	0	0	0	0	0	0	0	0	0	0	0	0	0	0	0
04:15	0	1	0	0	0	0	0	0	0	0	0	0	0	0	1
04:30	0	0	1	0	0	0	0	0	0	0	0	0	0	0	1
04:45	0	1	1	0	0	0	0	0	0	0	0	0	0	0	2
05:00	0	2	2	0	0	0	0	0	0	0	0	0	0	0	4
05:15	0	3	0	0	1	0	0	0	0	0	0	0	0	0	4
05:30	0	1	1	0	0	0	0	0	0	0	0	0	0	0	2
05:45	0	1	0	0	2	0	0	0	0	0	0	0	0	0	3
06:00	0	6	1	0	1	0	0	0	0	0	0	0	0	0	8
06:15	0	11	2	0	4	0	0	0	0	0	0	0	0	0	17
06:30	0	3	1	0	0	0	0	0	0	0	0	0	0	0	4
06:45	0	4	3	0	1	0	0	0	0	0	0	0	0	0	8
07:00	0	6	2	0	0	0	0	0	0	0	0	0	0	0	8
07:15	0	9	1	0	3	0	0	0	0	0	0	0	0	0	13
07:30	0	22	7	0	4	0	0	0	0	0	0	0	0	0	33
07:45	0	2	4	0	1	0	0	0	0	0	0	0	0	0	7
08:00	0	4	4	0	2	0	0	0	0	0	0	1	0	0	11
08:15	0	11	4	1	2	0	0	0	0	0	0	0	0	0	18
08:30	0	8	3	0	2	0	0	0	0	0	0	0	0	0	13
08:45	0	25	15	1	7	0	0	0	0	0	0	1	0	0	49
09:00	0	5	6	0	2	0	0	0	0	0	0	0	0	0	13
09:15	0	8	4	1	2	0	0	0	0	0	0	0	0	0	15
09:30	0	12	2	1	4	0	0	0	0	0	0	0	0	1	20
09:45	0	6	3	1	3	0	0	0	0	0	0	0	0	0	13
10:00	0	31	15	3	11	0	0	0	0	0	0	0	0	1	61
10:15	0	2	2	0	2	0	0	0	0	0	0	0	0	1	7
10:30	0	8	1	1	1	0	0	0	0	0	0	0	0	0	11
10:45	0	7	4	0	1	0	0	0	0	0	0	0	0	0	12
11:00	0	5	2	1	2	0	0	1	0	0	0	0	0	0	11
11:15	0	22	9	2	6	0	0	1	0	0	0	0	0	1	41
11:30	0	9	3	0	5	0	0	0	0	0	0	0	0	0	17
11:45	1	11	2	0	3	0	0	0	0	0	0	0	0	1	18
12:00	0	11	3	0	2	0	0	2	0	0	0	0	0	0	18
12:15	0	5	2	0	8	0	0	0	0	0	0	0	0	0	15
12:30	1	36	10	0	18	0	0	2	0	0	0	0	0	0	68
12:45	0	7	1	0	5	0	0	1	0	0	0	0	0	0	14
13:00	0	3	2	0	2	0	0	0	0	0	0	0	0	0	7
13:15	2	13	4	0	3	0	0	0	0	0	0	0	0	0	22
13:30	0	8	7	0	4	0	0	0	0	0	0	0	0	0	19
13:45	2	31	14	0	14	0	0	1	0	0	0	0	0	0	62
<b>Total</b>	<b>3</b>	<b>183</b>	<b>74</b>	<b>6</b>	<b>64</b>	<b>0</b>	<b>0</b>	<b>4</b>	<b>0</b>	<b>0</b>	<b>0</b>	<b>1</b>	<b>0</b>	<b>3</b>	<b>338</b>
<b>Percent</b>	<b>0.9%</b>	<b>54.1%</b>	<b>21.9%</b>	<b>1.8%</b>	<b>18.9%</b>	<b>0.0%</b>	<b>0.0%</b>	<b>1.2%</b>	<b>0.0%</b>	<b>0.0%</b>	<b>0.0%</b>	<b>0.3%</b>	<b>0.0%</b>	<b>0.9%</b>	



## All Traffic Data Services

1st Ave btwn Hazeldell & Walnut

Site Code: 21984

Latitude: 0' 0.0000 Undefined

Longitude: 0' 0.0000 Undefined

EB, WB

Start Time	Bikes	Cars & Trailer	2 Axle Long	Buses	2 Axle 6 Tire	3 Axle Single	4 Axle Single	<5 Axl Double	5 Axle Double	>6 Axl Double	<6 Axl Multi	6 Axle Multi	>6 Axl Multi	Not Classe	Total
12 PM	0	11	5	0	5	0	0	0	0	0	0	0	0	0	21
12:15	0	14	5	0	1	0	0	0	0	0	0	0	0	0	20
12:30	0	8	1	0	5	0	0	0	0	0	0	0	0	0	14
12:45	0	12	3	1	2	2	0	0	1	0	0	0	0	0	21
	0	45	14	1	13	2	0	0	1	0	0	0	0	0	76
13:00	1	9	5	0	2	1	0	0	0	0	0	0	0	0	18
13:15	1	10	10	0	4	0	0	0	1	0	0	0	0	0	26
13:30	0	8	4	0	2	0	0	0	0	0	0	0	0	0	14
13:45	1	17	5	0	3	1	0	0	0	0	0	0	0	0	27
	3	44	24	0	11	2	0	0	1	0	0	0	0	0	85
14:00	0	9	6	0	2	0	0	0	0	0	0	0	0	0	17
14:15	0	8	5	1	7	0	0	0	0	0	0	0	0	0	21
14:30	0	11	3	0	1	0	0	1	0	0	0	0	0	0	16
14:45	0	12	7	1	10	0	0	0	0	0	0	0	0	0	30
	0	40	21	2	20	0	0	1	0	0	0	0	0	0	84
15:00	0	8	3	1	1	0	0	0	0	0	0	0	0	0	13
15:15	0	14	3	0	5	0	0	0	0	0	0	0	0	1	23
15:30	0	11	4	0	4	0	0	0	0	0	0	0	0	0	19
15:45	0	10	7	0	6	0	0	0	0	0	0	0	0	0	23
	0	43	17	1	16	0	0	0	0	0	0	0	0	1	78
16:00	0	17	8	2	3	0	0	0	0	0	0	0	0	0	30
16:15	0	14	2	1	3	0	0	0	0	0	0	0	0	0	20
16:30	1	19	5	0	4	0	0	0	0	0	0	0	0	2	31
16:45	2	19	4	0	3	0	0	0	0	0	0	0	0	0	28
	3	69	19	3	13	0	0	0	0	0	0	0	0	2	109
17:00	0	8	4	0	7	0	0	1	0	0	0	0	0	0	20
17:15	2	13	11	0	2	0	0	1	0	0	0	0	0	0	29
17:30	0	15	4	0	2	0	0	0	0	0	0	0	0	0	21
17:45	0	8	4	0	1	0	0	1	0	0	0	0	0	0	14
	2	44	23	0	12	0	0	3	0	0	0	0	0	0	84
18:00	0	14	6	0	4	0	0	0	0	0	0	0	0	0	24
18:15	0	9	4	0	4	0	0	1	0	0	0	0	0	0	18
18:30	0	8	4	0	5	0	0	0	0	0	0	0	0	0	17
18:45	0	7	4	0	4	0	0	0	0	0	0	0	0	0	15
	0	38	18	0	17	0	0	1	0	0	0	0	0	0	74
19:00	0	3	5	0	2	0	0	0	0	0	0	0	0	0	10
19:15	0	5	4	0	2	0	0	0	0	0	0	0	0	0	11
19:30	0	3	1	0	2	0	0	0	0	0	0	0	0	0	6
19:45	0	11	0	0	2	0	0	0	0	0	0	0	0	0	13
	0	22	10	0	8	0	0	0	0	0	0	0	0	0	40
20:00	0	11	4	0	0	0	0	0	0	0	0	0	0	1	16
20:15	1	1	1	0	1	0	0	0	0	0	0	0	0	1	5
20:30	0	7	2	0	0	0	0	0	0	0	0	0	0	0	9
20:45	0	3	2	0	0	0	0	0	0	0	0	0	0	0	5
	1	22	9	0	1	0	0	0	0	0	0	0	0	2	35
21:00	0	5	3	0	0	0	0	0	0	0	0	0	0	0	8
21:15	0	3	1	0	0	0	0	0	0	0	0	0	0	0	4
21:30	0	2	1	0	1	0	0	0	0	0	0	0	0	0	4
21:45	0	1	1	0	0	0	0	0	0	0	0	0	0	0	2
	0	11	6	0	1	0	0	0	0	0	0	0	0	0	18
22:00	0	2	0	0	0	0	0	0	0	0	0	0	0	0	2
22:15	0	3	0	0	0	0	0	0	0	0	0	0	0	0	3
22:30	0	1	0	0	2	0	0	0	0	0	0	0	0	0	3
22:45	0	1	2	0	0	0	0	0	0	0	0	0	0	0	3
	0	7	2	0	2	0	0	0	0	0	0	0	0	0	11
23:00	0	1	1	0	0	1	0	0	0	0	0	0	0	0	3
23:15	0	3	1	0	0	0	0	0	0	0	0	0	0	0	4
23:30	0	2	1	0	0	0	0	0	0	0	0	0	0	0	3
23:45	0	3	0	0	0	0	0	0	0	0	0	0	0	0	3
	0	9	3	0	0	1	0	0	0	0	0	0	0	0	13
Total	9	394	166	7	114	5	0	5	2	0	0	0	0	5	707
Percent	1.3%	55.7%	23.5%	1.0%	16.1%	0.7%	0.0%	0.7%	0.3%	0.0%	0.0%	0.0%	0.0%	0.7%	
Grand Total	12	577	240	13	178	5	0	9	2	0	0	1	0	8	1045
Percent	1.1%	55.2%	23.0%	1.2%	17.0%	0.5%	0.0%	0.9%	0.2%	0.0%	0.0%	0.1%	0.0%	0.8%	

### All Traffic Data Services

1st Ave btwn Hazeldell & Walnut

Site Code: 21984

Latitude: 0' 0.0000 Undefined

Longitude: 0' 0.0000 Undefined

EB

Start Time	15	20	25	30	35	40	45	50	55	60	65	70	75	999	Total
02/19/20	0	0	0	0	0	0	0	0	0	0	0	0	0	0	0
00:15	0	0	0	0	0	0	1	0	0	0	0	0	0	0	1
00:30	0	0	0	0	0	1	0	0	0	0	0	0	0	0	1
00:45	0	0	0	0	0	0	0	0	0	0	0	0	0	0	0
01:00	0	0	0	0	0	1	1	0	0	0	0	0	0	0	2
01:15	0	0	0	0	0	0	0	0	0	0	0	0	0	0	0
01:30	0	0	0	0	0	0	0	0	0	0	0	0	0	0	0
01:45	0	0	0	0	0	0	0	0	0	0	0	0	0	0	0
02:00	0	0	0	0	0	0	0	0	0	0	0	0	0	0	0
02:15	0	0	0	0	1	0	0	0	0	0	0	0	0	0	1
02:30	0	0	0	0	0	0	0	0	0	0	0	0	0	0	0
02:45	0	0	0	0	0	0	0	0	0	0	0	0	0	0	0
03:00	0	0	0	0	1	0	0	0	0	0	0	0	0	0	1
03:15	0	0	0	0	0	0	0	0	0	0	0	0	0	0	0
03:30	0	0	0	0	0	0	0	0	0	0	0	0	0	0	0
03:45	0	0	0	0	0	0	0	0	0	0	0	0	0	0	0
04:00	0	0	0	0	0	0	0	0	0	0	0	0	0	0	0
04:15	0	0	0	0	0	0	0	0	0	0	0	0	0	0	0
04:30	0	0	0	0	0	0	0	0	0	0	0	0	0	0	0
04:45	0	0	0	0	0	0	0	0	0	0	0	0	0	0	0
05:00	0	0	0	0	0	0	0	0	0	0	0	0	0	0	0
05:15	0	0	0	0	0	1	0	0	0	0	0	0	0	0	1
05:30	0	0	0	0	0	0	0	0	0	0	0	0	0	0	0
05:45	0	0	0	0	1	3	0	0	0	0	0	0	0	0	4
06:00	0	0	0	0	1	4	0	0	0	0	0	0	0	0	5
06:15	0	0	0	1	0	1	2	0	0	0	0	0	0	0	4
06:30	0	0	0	0	2	0	0	0	0	0	0	0	0	0	2
06:45	0	0	0	1	0	1	1	1	0	0	0	0	0	0	4
07:00	0	0	0	2	2	2	3	1	0	0	0	0	0	0	10
07:15	0	0	0	0	1	1	1	0	0	0	0	0	0	0	3
07:30	0	0	1	1	2	0	0	0	0	0	0	0	0	0	4
07:45	0	0	1	0	2	2	2	0	0	0	0	0	0	0	7
08:00	0	0	0	0	1	0	0	0	0	0	0	0	0	0	1
08:15	0	0	2	1	6	3	3	0	0	0	0	0	0	0	15
08:30	0	0	1	0	0	1	0	0	0	0	0	0	0	0	2
08:45	0	0	2	0	1	0	0	0	0	0	0	0	0	0	3
09:00	1	0	0	4	0	4	1	0	1	0	0	0	0	0	11
09:15	0	0	0	0	3	1	2	2	0	0	0	0	0	0	8
09:30	1	0	3	4	4	6	3	2	1	0	0	0	0	0	24
09:45	0	1	0	0	0	1	1	0	0	0	0	0	0	0	3
10:00	0	0	1	0	0	0	0	0	1	0	0	0	0	0	2
10:15	0	0	0	0	2	4	2	1	0	0	0	0	0	0	9
10:30	0	0	0	0	0	3	1	0	1	0	0	0	0	0	5
10:45	0	1	1	0	2	8	4	1	2	0	0	0	0	0	19
11:00	0	0	0	0	0	1	2	3	0	0	0	0	0	0	6
11:15	1	0	1	2	0	5	0	0	0	0	0	0	0	0	9
11:30	0	0	0	0	1	3	2	2	0	0	0	0	0	0	8
11:45	0	0	0	1	2	3	1	0	0	0	0	0	0	0	7
Total	2	1	9	16	24	45	21	13	3	0	0	0	0	0	134



### All Traffic Data Services

1st Ave btwn Hazeldell & Walnut

Site Code: 21984

Latitude: 0' 0.0000 Undefined

Longitude: 0' 0.0000 Undefined

WB	Start Time	15	20	25	30	35	40	45	50	55	60	65	70	75	999	Total
	02/19/20	0	0	0	0	0	0	0	0	0	0	0	0	0	0	0
	00:15	0	0	0	0	0	0	0	0	0	0	0	0	0	0	0
	00:30	0	0	0	0	0	0	0	0	0	0	0	0	0	0	0
	00:45	0	0	0	0	0	0	0	0	0	0	0	0	0	0	0
	01:00	0	0	0	0	0	0	0	0	0	0	0	0	0	0	0
	01:15	0	0	0	0	0	0	0	0	0	0	0	0	0	0	0
	01:30	0	0	0	0	0	0	0	0	0	0	0	0	0	0	0
	01:45	0	0	0	0	0	0	0	0	0	0	0	0	0	0	0
	02:00	0	0	0	0	0	0	0	0	0	0	0	0	0	0	0
	02:15	0	0	0	0	0	0	0	0	0	0	0	0	0	0	0
	02:30	0	0	0	0	0	0	0	0	0	0	0	0	0	0	0
	02:45	0	0	0	0	0	0	0	0	0	0	0	0	0	0	0
	03:00	0	0	0	0	0	0	0	0	0	0	0	0	0	0	0
	03:15	0	0	0	0	0	0	0	0	0	0	0	0	0	0	0
	03:30	0	0	0	0	0	0	0	0	0	0	0	0	0	0	0
	03:45	0	0	0	0	0	0	0	0	0	0	0	0	0	0	0
	04:00	0	0	0	0	0	1	0	0	0	0	0	0	0	0	1
	04:15	0	0	0	0	0	0	0	0	0	0	0	0	0	0	0
	04:30	0	0	0	0	0	0	1	0	0	0	0	0	0	0	1
	04:45	0	0	0	0	0	0	1	1	0	0	0	0	0	0	2
	05:00	0	0	0	0	0	1	2	1	0	0	0	0	0	0	4
	05:15	0	0	0	0	1	1	1	0	1	0	0	0	0	0	3
	05:30	0	0	0	0	0	1	1	1	0	0	0	0	0	0	3
	05:45	0	0	0	0	1	1	1	1	0	0	0	0	0	0	4
	06:00	0	0	0	0	2	4	3	2	1	0	0	0	0	0	12
	06:15	0	0	0	2	0	2	0	0	0	0	0	0	0	0	4
	06:30	0	0	0	0	3	1	1	1	0	0	0	0	0	0	6
	06:45	0	0	0	0	3	2	2	1	1	0	0	0	0	0	9
	07:00	0	0	0	2	8	5	4	2	2	0	0	0	0	0	23
	07:15	0	0	0	0	0	3	1	0	0	0	0	0	0	0	4
	07:30	0	0	0	2	3	0	2	0	0	0	0	0	0	0	7
	07:45	0	0	0	0	6	4	1	0	0	0	0	0	0	0	11
	08:00	0	0	0	1	1	5	4	1	0	0	0	0	0	0	12
	08:15	0	0	0	3	4	11	2	0	0	0	0	0	0	0	34
	08:30	0	0	0	2	1	5	2	0	1	0	0	0	0	0	11
	08:45	0	0	0	1	2	2	4	3	0	0	0	0	0	0	12
	09:00	0	0	0	4	2	1	1	0	1	0	0	0	0	0	9
	09:15	0	0	0	0	1	1	3	0	0	0	0	0	0	0	5
	09:30	0	0	0	3	8	10	10	4	1	1	0	0	0	0	37
	09:45	0	0	1	0	0	2	1	0	0	0	0	0	0	0	4
	10:00	0	0	0	2	5	2	0	0	0	0	0	0	0	0	9
	10:15	0	0	0	0	2	1	0	0	0	0	0	0	0	0	3
	10:30	0	0	0	2	1	0	1	1	0	0	1	0	0	0	6
	10:45	0	0	1	2	3	9	5	1	0	0	1	0	0	0	22
	11:00	0	0	0	1	0	6	3	0	1	0	0	0	0	0	11
	11:15	0	0	1	2	1	3	0	1	1	0	0	0	0	0	9
	11:30	0	0	0	0	2	8	0	0	0	0	0	0	0	0	10
	11:45	0	0	0	1	3	4	0	0	0	0	0	0	0	0	8
	Total	0	0	3	18	45	71	42	16	7	1	1	0	0	0	204



# All Traffic Data Services

1st Ave btwn Hazeldell & Walnut

Site Code: 21984

Latitude: 0' 0.0000 Undefined

Longitude: 0' 0.0000 Undefined

WB Start Time	15	16 20	21 25	26 30	31 35	36 40	41 45	46 50	51 55	56 60	61 65	66 70	71 75	76 999	Total
12 PM	0	0	0	3	3	4	0	0	0	0	0	0	0	0	10
12:15	0	0	0	0	4	1	1	1	0	0	0	0	0	0	7
12:30	0	0	0	2	0	5	0	1	0	0	0	0	0	0	8
12:45	1	1	0	3	2	2	2	1	0	0	0	0	0	0	12
13:00	1	1	0	8	9	12	3	3	0	0	0	0	0	0	37
13:00	0	0	2	1	0	3	1	2	1	0	0	0	0	0	10
13:15	0	0	0	0	1	5	5	0	1	0	0	0	0	0	12
13:30	0	0	0	2	1	3	2	0	0	0	0	0	0	0	8
13:45	0	0	0	1	4	2	3	0	0	0	0	0	0	0	10
14:00	0	0	2	4	6	13	11	2	2	0	0	0	0	0	40
14:15	0	0	0	1	4	4	1	1	0	0	0	0	0	0	11
14:15	0	0	0	0	3	4	3	2	0	0	0	0	0	0	12
14:30	0	0	0	1	2	2	1	1	1	0	0	0	0	0	8
14:45	0	0	1	2	3	3	2	3	0	0	0	0	0	0	14
15:00	0	0	1	4	12	13	7	7	1	0	0	0	0	0	45
15:00	0	0	0	1	3	3	2	0	0	0	0	0	0	0	9
15:15	0	0	0	1	3	1	1	1	0	0	0	0	0	0	7
15:30	0	0	0	0	1	6	3	1	0	0	0	0	0	0	11
15:45	0	0	0	1	1	3	1	0	0	0	0	0	0	0	7
16:00	0	0	0	3	8	11	9	3	0	0	0	0	0	0	34
16:00	0	0	0	3	0	6	6	2	0	0	0	0	0	0	17
16:15	0	0	0	0	2	2	5	0	0	0	0	0	0	0	9
16:30	0	0	0	1	3	5	5	2	1	0	0	0	0	0	17
16:45	0	0	0	0	4	3	3	2	1	0	0	0	0	0	13
17:00	0	0	0	4	9	16	19	6	2	0	0	0	0	0	56
17:00	0	0	0	0	0	5	2	0	0	0	0	0	0	0	7
17:15	0	0	0	1	4	5	2	0	0	0	0	0	0	0	12
17:30	0	0	0	0	3	2	1	2	1	0	0	0	0	0	9
17:45	0	0	0	0	3	3	1	0	0	0	0	0	0	0	7
18:00	0	0	0	1	10	15	6	2	1	0	0	0	0	0	35
18:00	0	0	0	1	2	7	0	0	0	0	0	0	0	0	10
18:15	0	0	0	0	3	5	1	0	0	0	0	0	0	0	9
18:30	0	0	0	0	2	4	0	1	0	0	0	0	0	0	7
18:45	0	0	0	1	1	1	2	0	0	0	0	0	0	0	5
19:00	0	0	0	2	8	17	3	1	0	0	0	0	0	0	31
19:00	0	0	0	0	1	0	0	0	0	0	0	0	0	0	1
19:15	0	0	0	0	2	1	0	0	0	0	0	0	0	0	3
19:30	0	0	0	0	1	1	0	0	0	0	0	0	0	0	2
19:45	0	0	0	2	2	3	1	0	0	0	0	0	0	0	8
20:00	0	0	0	2	6	5	1	0	0	0	0	0	0	0	14
20:00	0	0	0	0	1	1	1	0	0	0	0	0	0	0	3
20:15	0	0	0	0	0	0	0	0	0	0	0	0	0	0	0
20:30	0	0	0	0	1	0	1	0	0	0	0	0	0	0	2
20:45	0	0	0	0	0	2	0	0	0	0	0	0	0	0	2
21:00	0	0	0	0	2	3	2	0	0	0	0	0	0	0	7
21:00	0	0	0	1	1	0	1	1	0	0	0	0	0	0	4
21:15	0	0	0	0	0	0	0	0	0	0	0	0	0	0	0
21:30	0	0	0	0	0	2	0	0	0	0	0	2	0	0	2
21:45	0	0	0	0	0	0	1	1	0	0	0	0	0	0	2
22:00	0	0	0	1	1	2	2	2	0	0	0	0	0	0	8
22:00	0	0	0	0	0	2	0	0	0	0	0	0	0	0	2
22:15	0	0	0	0	0	0	0	0	0	0	0	0	0	0	0
22:30	0	0	0	0	0	0	0	0	0	0	0	0	0	0	0
22:45	0	0	0	0	1	0	0	0	0	0	0	0	0	0	1
23:00	0	0	0	0	1	2	0	0	0	0	0	0	0	0	3
23:00	0	0	0	0	1	0	0	0	0	0	0	0	0	0	1
23:15	0	0	0	0	1	0	0	0	0	0	0	0	0	0	1
23:30	0	0	0	0	0	0	0	0	0	0	0	0	0	0	0
23:45	0	0	0	0	0	1	1	1	0	0	0	0	0	0	3
Total	1	1	3	29	74	110	64	27	6	0	0	0	0	0	315
Grand Total	1	1	6	47	119	181	106	43	13	1	1	0	0	0	519

15th Percentile : 30 MPH  
 50th Percentile : 37 MPH  
 85th Percentile : 44 MPH  
 95th Percentile : 48 MPH

Stats  
 Mean Speed(Average) : 38 MPH  
 10 MPH Pace Speed : 31-40 MPH  
 Number in Pace : 300  
 Percent in Pace : 57.8%  
 Number of Vehicles > 55 MPH : 2  
 Percent of Vehicles > 55 MPH : 0.4%

# **HCM Analysis Reports**

---

# HCM Signalized Intersection Capacity Analysis

## 1: OR 99E & Redwood St/Sequoia Pkwy

03/13/2020



Movement	EBL	EBT	EBR	WBL	WBT	WBR	NBL	NBT	NBR	SBL	SBT	SBR
Lane Configurations												
Traffic Volume (vph)	10	15	50	170	15	60	25	730	80	60	545	5
Future Volume (vph)	10	15	50	170	15	60	25	730	80	60	545	5
Ideal Flow (vphpl)	1750	1750	1750	1750	1750	1750	1750	1750	1750	1750	1750	1750
Total Lost time (s)	4.0	4.0		4.0	4.0	4.0	4.0	5.4	5.4	4.0	5.4	
Lane Util. Factor	1.00	1.00		0.97	1.00	1.00	1.00	0.95	1.00	1.00	0.95	
Frpb, ped/bikes	1.00	0.99		1.00	1.00	1.00	1.00	1.00	1.00	1.00	1.00	
Flpb, ped/bikes	1.00	1.00		1.00	1.00	1.00	1.00	1.00	1.00	1.00	1.00	
Frt	1.00	0.88		1.00	1.00	0.85	1.00	1.00	0.85	1.00	1.00	
Flt Protected	0.95	1.00		0.95	1.00	1.00	0.95	1.00	1.00	0.95	1.00	
Satd. Flow (prot)	1662	1507		3072	1750	1261	1599	3079	1444	1511	3048	
Flt Permitted	0.95	1.00		0.95	1.00	1.00	0.95	1.00	1.00	0.95	1.00	
Satd. Flow (perm)	1662	1507		3072	1750	1261	1599	3079	1444	1511	3048	
Peak-hour factor, PHF	0.90	0.90	0.90	0.90	0.90	0.90	0.90	0.90	0.90	0.90	0.90	0.90
Adj. Flow (vph)	11	17	56	189	17	67	28	811	89	67	606	6
RTOR Reduction (vph)	0	52	0	0	0	58	0	0	48	0	0	0
Lane Group Flow (vph)	11	21	0	189	17	9	28	811	41	67	612	0
Confl. Peds. (#/hr)			1	1			1					1
Heavy Vehicles (%)	0%	0%	2%	5%	0%	18%	4%	8%	3%	10%	9%	0%
Turn Type	Split	NA		Split	NA	Perm	Prot	NA	Perm	Prot	NA	
Protected Phases	8	8		4	4		1	6		5	2	
Permitted Phases						4			6			
Actuated Green, G (s)	5.3	5.3		9.6	9.6	9.6	2.5	32.5	32.5	6.4	36.4	
Effective Green, g (s)	5.3	5.3		9.6	9.6	9.6	2.5	32.5	32.5	6.4	36.4	
Actuated g/C Ratio	0.07	0.07		0.13	0.13	0.13	0.04	0.46	0.46	0.09	0.51	
Clearance Time (s)	4.0	4.0		4.0	4.0	4.0	4.0	5.4	5.4	4.0	5.4	
Vehicle Extension (s)	2.3	2.3		2.3	2.3	2.3	2.3	5.5	5.5	2.3	5.5	
Lane Grp Cap (vph)	123	112		414	235	170	56	1405	659	135	1558	
v/s Ratio Prot	0.01	c0.01		c0.06	0.01		0.02	c0.26		c0.04	c0.20	
v/s Ratio Perm						0.01			0.03			
v/c Ratio	0.09	0.19		0.46	0.07	0.05	0.50	0.58	0.06	0.50	0.39	
Uniform Delay, d1	30.7	30.9		28.4	26.9	26.8	33.7	14.3	10.8	30.9	10.6	
Progression Factor	1.00	1.00		1.00	1.00	1.00	1.00	1.00	1.00	1.00	1.00	
Incremental Delay, d2	0.2	0.5		0.5	0.1	0.1	4.0	1.0	0.1	1.7	0.4	
Delay (s)	30.9	31.4		28.9	27.0	26.9	37.8	15.3	10.9	32.5	11.0	
Level of Service	C	C		C	C	C	D	B	B	C	B	
Approach Delay (s)		31.3			28.3			15.6			13.2	
Approach LOS		C			C			B			B	

Intersection Summary		
HCM 2000 Control Delay	17.2	HCM 2000 Level of Service
HCM 2000 Volume to Capacity ratio	0.50	B
Actuated Cycle Length (s)	71.2	Sum of lost time (s)
Intersection Capacity Utilization	48.6%	17.4
Analysis Period (min)	15	ICU Level of Service
		A

c Critical Lane Group

HCM Signalized Intersection Capacity Analysis  
 2: OR 99 E & NE Territorial Rd/SE Territorial Rd

03/13/2020



Movement	EBL	EBT	EBR	WBL	WBT	WBR	NBL	NBT	NBR	SBL	SBT	SBR
Lane Configurations	↖	↗		↖	↗		↖	↕		↖	↗	↖
Traffic Volume (vph)	230	15	15	20	10	5	5	875	10	5	625	75
Future Volume (vph)	230	15	15	20	10	5	5	875	10	5	625	75
Ideal Flow (vphpl)	1750	1750	1750	1750	1750	1750	1750	1750	1750	1750	1750	1750
Total Lost time (s)	4.5	4.5		4.5	4.5		4.0	6.0		4.0	6.0	6.0
Lane Util. Factor	1.00	1.00		1.00	1.00		1.00	0.95		1.00	0.95	1.00
Frt	1.00	0.93		1.00	0.95		1.00	1.00		1.00	1.00	0.85
Flt Protected	0.95	1.00		0.95	1.00		0.95	1.00		0.95	1.00	1.00
Satd. Flow (prot)	1646	1572		1583	1395		1458	3105		950	3167	1444
Flt Permitted	0.75	1.00		0.73	1.00		0.95	1.00		0.95	1.00	1.00
Satd. Flow (perm)	1293	1572		1225	1395		1458	3105		950	3167	1444
Peak-hour factor, PHF	0.89	0.89	0.89	0.89	0.89	0.89	0.89	0.89	0.89	0.89	0.89	0.89
Adj. Flow (vph)	258	17	17	22	11	6	6	983	11	6	702	84
RTOR Reduction (vph)	0	11	0	0	4	0	0	1	0	0	0	45
Lane Group Flow (vph)	258	23	0	22	13	0	6	993	0	6	702	39
Heavy Vehicles (%)	1%	0%	6%	5%	11%	33%	14%	7%	0%	75%	5%	3%
Turn Type	Perm	NA		Perm	NA		Prot	NA		Prot	NA	Perm
Protected Phases		8			4		1	6		5	2	
Permitted Phases	8			4								2
Actuated Green, G (s)	23.2	23.2		23.2	23.2		0.8	32.6		1.0	32.8	32.8
Effective Green, g (s)	23.2	23.2		23.2	23.2		0.8	32.6		1.0	32.8	32.8
Actuated g/C Ratio	0.33	0.33		0.33	0.33		0.01	0.46		0.01	0.46	0.46
Clearance Time (s)	4.5	4.5		4.5	4.5		4.0	6.0		4.0	6.0	6.0
Vehicle Extension (s)	2.5	2.5		2.5	2.5		2.3	5.4		2.3	5.4	5.4
Lane Grp Cap (vph)	420	511		398	453		16	1419		13	1456	664
v/s Ratio Prot		0.01			0.01		0.00	c0.32		c0.01	0.22	
v/s Ratio Perm	c0.20			0.02								0.03
v/c Ratio	0.61	0.04		0.06	0.03		0.38	0.70		0.46	0.48	0.06
Uniform Delay, d1	20.3	16.5		16.5	16.4		35.0	15.4		34.9	13.4	10.7
Progression Factor	1.00	1.00		1.00	1.00		1.00	1.00		1.00	1.00	1.00
Incremental Delay, d2	2.3	0.0		0.0	0.0		8.4	2.1		14.3	0.6	0.1
Delay (s)	22.6	16.5		16.6	16.4		43.4	17.6		49.2	14.0	10.8
Level of Service	C	B		B	B		D	B		D	B	B
Approach Delay (s)		21.8			16.5			17.7			13.9	
Approach LOS		C			B			B			B	

Intersection Summary

HCM 2000 Control Delay	16.8	HCM 2000 Level of Service	B
HCM 2000 Volume to Capacity ratio	0.66		
Actuated Cycle Length (s)	71.3	Sum of lost time (s)	14.5
Intersection Capacity Utilization	55.9%	ICU Level of Service	B
Analysis Period (min)	15		
c Critical Lane Group			



Intersection						
Int Delay, s/veh	15					
Movement	WBL	WBR	NBT	NBR	SBL	SBT
Lane Configurations	↘	↗	↕		↘	↗
Traffic Vol, veh/h	75	140	1040	60	60	625
Future Vol, veh/h	75	140	1040	60	60	625
Conflicting Peds, #/hr	0	0	0	0	0	0
Sign Control	Stop	Stop	Free	Free	Free	Free
RT Channelized	-	None	-	None	-	None
Storage Length	0	0	-	-	340	-
Veh in Median Storage, #	0	-	0	-	-	0
Grade, %	0	-	0	-	-	0
Peak Hour Factor	86	86	86	86	86	86
Heavy Vehicles, %	7	0	7	2	5	6
Mvmt Flow	87	163	1209	70	70	727

Major/Minor	Minor1	Major1	Major2		
Conflicting Flow All	1748	640	0	0	1279
Stage 1	1244	-	-	-	-
Stage 2	504	-	-	-	-
Critical Hdwy	6.94	6.9	-	-	4.2
Critical Hdwy Stg 1	5.94	-	-	-	-
Critical Hdwy Stg 2	5.94	-	-	-	-
Follow-up Hdwy	3.57	3.3	-	-	2.25
Pot Cap-1 Maneuver	~ 73	423	-	-	523
Stage 1	225	-	-	-	-
Stage 2	558	-	-	-	-
Platoon blocked, %					
Mov Cap-1 Maneuver	~ 63	423	-	-	523
Mov Cap-2 Maneuver	~ 63	-	-	-	-
Stage 1	225	-	-	-	-
Stage 2	483	-	-	-	-

Approach	WB	NB	SB
HCM Control Delay, s	136.4	0	1.1
HCM LOS	F		

Minor Lane/Major Mvmt	NBT	NBR	WBLn1	WBLn2	SBL	SBT
Capacity (veh/h)	-	-	63	423	523	-
HCM Lane V/C Ratio	-	-	1.384	0.385	0.133	-
HCM Control Delay (s)	-	-	\$ 356.1	18.7	12.9	-
HCM Lane LOS	-	-	F	C	B	-
HCM 95th %tile Q(veh)	-	-	7.4	1.8	0.5	-

Notes  
 ~: Volume exceeds capacity    \$: Delay exceeds 300s    +: Computation Not Defined    \*: All major volume in platoon

HCM 2010 TWSC  
4: Sequoia Pkwy & Hazeldell Way

03/13/2020

Intersection												
Int Delay, s/veh	6.6											
Movement	EBL	EBT	EBR	WBL	WBT	WBR	NBL	NBT	NBR	SBL	SBT	SBR
Lane Configurations	↔	↔		↔	↔		↔	↔		↔	↕↕	↔
Traffic Vol, veh/h	90	10	30	5	20	50	20	105	10	60	75	20
Future Vol, veh/h	90	10	30	5	20	50	20	105	10	60	75	20
Conflicting Peds, #/hr	3	0	0	0	0	3	0	0	0	0	0	0
Sign Control	Stop	Stop	Stop	Stop	Stop	Stop	Free	Free	Free	Free	Free	Free
RT Channelized	-	-	None	-	-	None	-	-	None	-	-	Free
Storage Length	0	-	80	120	-	-	150	-	-	130	-	130
Veh in Median Storage, #	-	0	-	-	0	-	-	0	-	-	0	-
Grade, %	-	0	-	-	0	-	-	0	-	-	0	-
Peak Hour Factor	89	89	89	89	89	89	89	89	89	89	89	89
Heavy Vehicles, %	3	0	0	0	0	6	10	10	11	0	16	7
Mvmt Flow	101	11	34	6	22	56	22	118	11	67	84	22

Major/Minor	Minor2		Minor1		Major1			Major2				
Conflicting Flow All	428	391	42	350	386	127	84	0	0	129	0	0
Stage 1	218	218	-	168	168	-	-	-	-	-	-	-
Stage 2	210	173	-	182	218	-	-	-	-	-	-	-
Critical Hdwy	7.345	6.5	6.9	7.3	6.5	6.29	4.25	-	-	4.1	-	-
Critical Hdwy Stg 1	6.545	5.5	-	6.1	5.5	-	-	-	-	-	-	-
Critical Hdwy Stg 2	6.145	5.5	-	6.5	5.5	-	-	-	-	-	-	-
Follow-up Hdwy	3.5285	4	3.3	3.5	4	3.357	2.295	-	-	2.2	-	-
Pot Cap-1 Maneuver	522	548	1026	597	551	911	1459	-	-	1469	-	0
Stage 1	762	726	-	839	763	-	-	-	-	-	-	0
Stage 2	789	760	-	808	726	-	-	-	-	-	-	0
Platoon blocked, %								-	-	-	-	-
Mov Cap-1 Maneuver	450	515	1026	542	518	908	1459	-	-	1469	-	-
Mov Cap-2 Maneuver	450	515	-	542	518	-	-	-	-	-	-	-
Stage 1	751	693	-	826	752	-	-	-	-	-	-	-
Stage 2	705	749	-	734	693	-	-	-	-	-	-	-

Approach	EB		WB		NB		SB	
HCM Control Delay, s	13.5		10.5		1.1		3.4	
HCM LOS	B		B					

Minor Lane/Major Mvmt	NBL	NBT	NBR	EBLn1	EBLn2	WBLn1	WBLn2	SBL	SBT
Capacity (veh/h)	1459	-	-	450	822	542	747	1469	-
HCM Lane V/C Ratio	0.015	-	-	0.225	0.055	0.01	0.105	0.046	-
HCM Control Delay (s)	7.5	-	-	15.3	9.6	11.7	10.4	7.6	-
HCM Lane LOS	A	-	-	C	A	B	B	A	-
HCM 95th %tile Q(veh)	0	-	-	0.9	0.2	0	0.4	0.1	-

Intersection						
Int Delay, s/veh	1.4					
Movement	WBL	WBR	NBT	NBR	SBL	SBT
Lane Configurations	W		T			T
Traffic Vol, veh/h	5	15	90	5	10	65
Future Vol, veh/h	5	15	90	5	10	65
Conflicting Peds, #/hr	1	0	0	0	0	0
Sign Control	Stop	Stop	Free	Free	Free	Free
RT Channelized	-	None	-	None	-	None
Storage Length	0	-	-	-	-	-
Veh in Median Storage, #	0	-	0	-	-	0
Grade, %	0	-	0	-	-	0
Peak Hour Factor	88	88	92	92	92	92
Heavy Vehicles, %	20	20	6	0	30	3
Mvmt Flow	6	17	98	5	11	71

Major/Minor	Minor1	Major1	Major2			
Conflicting Flow All	195	101	0	0	103	0
Stage 1	101	-	-	-	-	-
Stage 2	94	-	-	-	-	-
Critical Hdwy	6.6	6.4	-	-	4.4	-
Critical Hdwy Stg 1	5.6	-	-	-	-	-
Critical Hdwy Stg 2	5.6	-	-	-	-	-
Follow-up Hdwy	3.68	3.48	-	-	2.47	-
Pot Cap-1 Maneuver	755	907	-	-	1331	-
Stage 1	880	-	-	-	-	-
Stage 2	886	-	-	-	-	-
Platoon blocked, %			-	-		-
Mov Cap-1 Maneuver	747	907	-	-	1331	-
Mov Cap-2 Maneuver	742	-	-	-	-	-
Stage 1	880	-	-	-	-	-
Stage 2	877	-	-	-	-	-

Approach	WB	NB	SB
HCM Control Delay, s	9.3	0	1
HCM LOS	A		

Minor Lane/Major Mvmt	NBT	NBRWBLn1	SBL	SBT
Capacity (veh/h)	-	-	859	1331
HCM Lane V/C Ratio	-	-	0.026	0.008
HCM Control Delay (s)	-	-	9.3	7.7
HCM Lane LOS	-	-	A	A
HCM 95th %tile Q(veh)	-	-	0.1	0

Intersection						
Int Delay, s/veh	2					
Movement	EBT	EBR	WBL	WBT	NBL	NBR
Lane Configurations						
Traffic Vol, veh/h	10	0	15	45	0	5
Future Vol, veh/h	10	0	15	45	0	5
Conflicting Peds, #/hr	0	0	0	0	0	0
Sign Control	Free	Free	Free	Free	Stop	Stop
RT Channelized	-	None	-	None	-	None
Storage Length	-	-	-	-	0	-
Veh in Median Storage, #	0	-	-	0	0	-
Grade, %	0	-	-	0	0	-
Peak Hour Factor	87	87	87	87	87	87
Heavy Vehicles, %	11	100	0	2	0	33
Mvmt Flow	11	0	17	52	0	6

Major/Minor	Major1	Major2	Minor1	Minor2	Minor3
Conflicting Flow All	0	0	11	0	97
Stage 1	-	-	-	-	11
Stage 2	-	-	-	-	86
Critical Hdwy	-	-	4.1	-	6.4
Critical Hdwy Stg 1	-	-	-	-	5.4
Critical Hdwy Stg 2	-	-	-	-	5.4
Follow-up Hdwy	-	-	2.2	-	3.5
Pot Cap-1 Maneuver	-	-	1621	-	907
Stage 1	-	-	-	-	1017
Stage 2	-	-	-	-	942
Platoon blocked, %	-	-	-	-	-
Mov Cap-1 Maneuver	-	-	1621	-	897
Mov Cap-2 Maneuver	-	-	-	-	897
Stage 1	-	-	-	-	1017
Stage 2	-	-	-	-	932

Approach	EB	WB	NB
HCM Control Delay, s	0	1.8	8.7
HCM LOS			A

Minor Lane/Major Mvmt	NBLn1	EBT	EBR	WBL	WBT
Capacity (veh/h)	986	-	-	1621	-
HCM Lane V/C Ratio	0.006	-	-	0.011	-
HCM Control Delay (s)	8.7	-	-	7.2	0
HCM Lane LOS	A	-	-	A	A
HCM 95th %tile Q(veh)	0	-	-	0	-



Intersection						
Int Delay, s/veh	5.9					
Movement	EBT	EBR	WBL	WBT	NBL	NBR
Lane Configurations						
Traffic Vol, veh/h	10	5	45	55	5	110
Future Vol, veh/h	10	5	45	55	5	110
Conflicting Peds, #/hr	0	0	0	0	0	0
Sign Control	Free	Free	Free	Free	Stop	Stop
RT Channelized	-	None	-	None	-	None
Storage Length	-	-	-	-	0	-
Veh in Median Storage, #	0	-	-	0	0	-
Grade, %	0	-	-	0	0	-
Peak Hour Factor	82	82	82	82	82	82
Heavy Vehicles, %	18	0	0	4	0	0
Mvmt Flow	12	6	55	67	6	134

Major/Minor	Major1	Major2	Minor1		
Conflicting Flow All	0	0	18	0	192
Stage 1	-	-	-	-	15
Stage 2	-	-	-	-	177
Critical Hdwy	-	-	4.1	-	6.4
Critical Hdwy Stg 1	-	-	-	-	5.4
Critical Hdwy Stg 2	-	-	-	-	5.4
Follow-up Hdwy	-	-	2.2	-	3.5
Pot Cap-1 Maneuver	-	-	1612	-	801
Stage 1	-	-	-	-	1013
Stage 2	-	-	-	-	859
Platoon blocked, %	-	-	-	-	-
Mov Cap-1 Maneuver	-	-	1612	-	773
Mov Cap-2 Maneuver	-	-	-	-	773
Stage 1	-	-	-	-	1013
Stage 2	-	-	-	-	829

Approach	EB	WB	NB
HCM Control Delay, s	0	3.3	8.9
HCM LOS			A

Minor Lane/Major Mvmt	NBLn1	EBT	EBR	WBL	WBT
Capacity (veh/h)	1052	-	-	1612	-
HCM Lane V/C Ratio	0.133	-	-	0.034	-
HCM Control Delay (s)	8.9	-	-	7.3	0
HCM Lane LOS	A	-	-	A	A
HCM 95th %tile Q(veh)	0.5	-	-	0.1	-

Intersection						
Int Delay, s/veh	2.3					
Movement	WBL	WBR	NBT	NBR	SBL	SBT
Lane Configurations						
Traffic Vol, veh/h	30	25	110	10	5	70
Future Vol, veh/h	30	25	110	10	5	70
Conflicting Peds, #/hr	0	0	0	0	0	0
Sign Control	Stop	Stop	Free	Free	Free	Free
RT Channelized	-	None	-	None	-	None
Storage Length	0	-	-	-	-	-
Veh in Median Storage, #	0	-	0	-	-	0
Grade, %	0	-	0	-	-	0
Peak Hour Factor	89	89	89	89	89	89
Heavy Vehicles, %	10	0	3	17	0	4
Mvmt Flow	34	28	124	11	6	79

Major/Minor	Minor1	Major1	Major2			
Conflicting Flow All	221	130	0	0	135	0
Stage 1	130	-	-	-	-	-
Stage 2	91	-	-	-	-	-
Critical Hdwy	6.5	6.2	-	-	4.1	-
Critical Hdwy Stg 1	5.5	-	-	-	-	-
Critical Hdwy Stg 2	5.5	-	-	-	-	-
Follow-up Hdwy	3.59	3.3	-	-	2.2	-
Pot Cap-1 Maneuver	750	925	-	-	1462	-
Stage 1	877	-	-	-	-	-
Stage 2	913	-	-	-	-	-
Platoon blocked, %			-	-	-	-
Mov Cap-1 Maneuver	747	925	-	-	1462	-
Mov Cap-2 Maneuver	747	-	-	-	-	-
Stage 1	877	-	-	-	-	-
Stage 2	909	-	-	-	-	-



























Approach	WB	NB	SB
HCM Control Delay, s	9.8	0	0.5
HCM LOS	A		

Minor Lane/Major Mvmt	NBT	NBRWBLn1	SBL	SBT
Capacity (veh/h)	-	-	819	1462
HCM Lane V/C Ratio	-	-	0.075	0.004
HCM Control Delay (s)	-	-	9.8	7.5
HCM Lane LOS	-	-	A	A
HCM 95th %tile Q(veh)	-	-	0.2	0

# HCM Signalized Intersection Capacity Analysis

## 1: OR 99E & Redwood St/Sequoia Pkwy

03/13/2020

												
Movement	EBL	EBT	EBR	WBL	WBT	WBR	NBL	NBT	NBR	SBL	SBT	SBR
Lane Configurations				 				 			 	
Traffic Volume (vph)	5	70	40	320	60	95	60	765	115	130	1015	20
Future Volume (vph)	5	70	40	320	60	95	60	765	115	130	1015	20
Ideal Flow (vphpl)	1750	1750	1750	1750	1750	1750	1750	1750	1750	1750	1750	1750
Total Lost time (s)	4.0	4.0		4.0	4.0	4.0	4.0	5.4	5.4	4.0	5.4	
Lane Util. Factor	1.00	1.00		0.97	1.00	1.00	1.00	0.95	1.00	1.00	0.95	
Frt	1.00	0.95		1.00	1.00	0.85	1.00	1.00	0.85	1.00	1.00	
Flt Protected	0.95	1.00		0.95	1.00	1.00	0.95	1.00	1.00	0.95	1.00	
Satd. Flow (prot)	1662	1615		3193	1750	1430	1599	3167	1430	1646	3190	
Flt Permitted	0.95	1.00		0.95	1.00	1.00	0.95	1.00	1.00	0.95	1.00	
Satd. Flow (perm)	1662	1615		3193	1750	1430	1599	3167	1430	1646	3190	
Peak-hour factor, PHF	0.91	0.91	0.91	0.91	0.91	0.91	0.91	0.91	0.91	0.91	0.91	0.91
Adj. Flow (vph)	5	77	44	352	66	104	66	841	126	143	1115	22
RTOR Reduction (vph)	0	21	0	0	0	88	0	0	72	0	1	0
Lane Group Flow (vph)	5	100	0	352	66	16	66	841	54	143	1136	0
Heavy Vehicles (%)	0%	1%	5%	1%	0%	4%	4%	5%	4%	1%	4%	0%
Turn Type	Split	NA		Split	NA	Perm	Prot	NA	Perm	Prot	NA	
Protected Phases	8	8		4	4		1	6		5	2	
Permitted Phases						4			6			
Actuated Green, G (s)	8.6	8.6		13.9	13.9	13.9	6.7	37.7	37.7	10.9	41.9	
Effective Green, g (s)	8.6	8.6		13.9	13.9	13.9	6.7	37.7	37.7	10.9	41.9	
Actuated g/C Ratio	0.10	0.10		0.16	0.16	0.16	0.08	0.43	0.43	0.12	0.47	
Clearance Time (s)	4.0	4.0		4.0	4.0	4.0	4.0	5.4	5.4	4.0	5.4	
Vehicle Extension (s)	2.3	2.3		2.3	2.3	2.3	2.3	5.5	5.5	2.3	5.5	
Lane Grp Cap (vph)	161	156		501	274	224	121	1349	609	202	1510	
v/s Ratio Prot	0.00	c0.06		c0.11	0.04		0.04	0.27		c0.09	c0.36	
v/s Ratio Perm						0.01			0.04			
v/c Ratio	0.03	0.64		0.70	0.24	0.07	0.55	0.62	0.09	0.71	0.75	
Uniform Delay, d1	36.2	38.5		35.3	32.7	31.8	39.4	19.9	15.1	37.3	19.1	
Progression Factor	1.00	1.00		1.00	1.00	1.00	1.00	1.00	1.00	1.00	1.00	
Incremental Delay, d2	0.0	7.3		3.9	0.3	0.1	3.4	1.4	0.2	9.6	2.7	
Delay (s)	36.2	45.8		39.3	32.9	31.9	42.9	21.3	15.3	46.9	21.8	
Level of Service	D	D		D	C	C	D	C	B	D	C	
Approach Delay (s)		45.4			37.0			21.9			24.6	
Approach LOS		D			D			C			C	
<b>Intersection Summary</b>												
HCM 2000 Control Delay			26.7	HCM 2000 Level of Service				C				
HCM 2000 Volume to Capacity ratio			0.75									
Actuated Cycle Length (s)			88.5	Sum of lost time (s)				17.4				
Intersection Capacity Utilization			62.5%	ICU Level of Service				B				
Analysis Period (min)			15									
c Critical Lane Group												

# HCM Signalized Intersection Capacity Analysis

## 2: OR 99 E & NE Territorial Rd/SE Territorial Rd

03/13/2020



Movement	EBL	EBT	EBR	WBL	WBT	WBR	NBL	NBT	NBR	SBL	SBT	SBR
Lane Configurations												
Traffic Volume (vph)	185	20	20	15	30	5	20	955	15	5	1050	260
Future Volume (vph)	185	20	20	15	30	5	20	955	15	5	1050	260
Ideal Flow (vphpl)	1750	1750	1750	1750	1750	1750	1750	1750	1750	1750	1750	1750
Total Lost time (s)	4.5	4.5		4.5	4.5		4.0	6.0		4.0	6.0	6.0
Lane Util. Factor	1.00	1.00		1.00	1.00		1.00	0.95		1.00	0.95	1.00
Frt	1.00	0.93		1.00	0.98		1.00	1.00		1.00	1.00	0.85
Flt Protected	0.95	1.00		0.95	1.00		0.95	1.00		0.95	1.00	1.00
Satd. Flow (prot)	1646	1579		1554	1714		1662	3184		1330	3167	1473
Flt Permitted	0.73	1.00		0.73	1.00		0.95	1.00		0.95	1.00	1.00
Satd. Flow (perm)	1271	1579		1193	1714		1662	3184		1330	3167	1473
Peak-hour factor, PHF	0.96	0.96	0.96	0.96	0.96	0.96	0.96	0.96	0.96	0.96	0.96	0.96
Adj. Flow (vph)	193	21	21	16	31	5	21	995	16	5	1094	271
RTOR Reduction (vph)	0	16	0	0	4	0	0	1	0	0	0	124
Lane Group Flow (vph)	193	26	0	16	32	0	21	1010	0	5	1094	147
Heavy Vehicles (%)	1%	0%	5%	7%	0%	0%	0%	4%	15%	25%	5%	1%
Turn Type	Perm	NA		Perm	NA		Prot	NA		Prot	NA	Perm
Protected Phases		8			4		1	6		5	2	
Permitted Phases	8			4								2
Actuated Green, G (s)	18.4	18.4		18.4	18.4		2.2	43.3		0.8	41.9	41.9
Effective Green, g (s)	18.4	18.4		18.4	18.4		2.2	43.3		0.8	41.9	41.9
Actuated g/C Ratio	0.24	0.24		0.24	0.24		0.03	0.56		0.01	0.54	0.54
Clearance Time (s)	4.5	4.5		4.5	4.5		4.0	6.0		4.0	6.0	6.0
Vehicle Extension (s)	2.5	2.5		2.5	2.5		2.3	5.4		2.3	5.4	5.4
Lane Grp Cap (vph)	303	377		285	409		47	1790		13	1723	801
v/s Ratio Prot		0.02			0.02		c0.01	0.32		0.00	c0.35	
v/s Ratio Perm	c0.15			0.01								0.10
v/c Ratio	0.64	0.07		0.06	0.08		0.45	0.56		0.38	0.63	0.18
Uniform Delay, d1	26.3	22.7		22.6	22.7		36.8	10.8		37.9	12.2	8.9
Progression Factor	1.00	1.00		1.00	1.00		1.00	1.00		1.00	1.00	1.00
Incremental Delay, d2	3.8	0.1		0.1	0.1		3.9	0.7		10.7	1.2	0.3
Delay (s)	30.1	22.7		22.7	22.8		40.7	11.5		48.5	13.4	9.2
Level of Service	C	C		C	C		D	B		D	B	A
Approach Delay (s)		28.8			22.7			12.1			12.7	
Approach LOS		C			C			B			B	

### Intersection Summary

HCM 2000 Control Delay	14.1	HCM 2000 Level of Service	B
HCM 2000 Volume to Capacity ratio	0.63		
Actuated Cycle Length (s)	77.0	Sum of lost time (s)	14.5
Intersection Capacity Utilization	58.1%	ICU Level of Service	B
Analysis Period (min)	15		
c Critical Lane Group			



**Intersection**

Int Delay, s/veh 9.4

Movement	WBL	WBR	NBT	NBR	SBL	SBT
Lane Configurations	↘	↗	↕		↘	↗
Traffic Vol, veh/h	50	70	990	100	140	1275
Future Vol, veh/h	50	70	990	100	140	1275
Conflicting Peds, #/hr	0	0	0	0	0	0
Sign Control	Stop	Stop	Free	Free	Free	Free
RT Channelized	-	None	-	None	-	None
Storage Length	0	0	-	-	340	-
Veh in Median Storage, #	0	-	0	-	-	0
Grade, %	0	-	0	-	-	0
Peak Hour Factor	96	96	96	96	96	96
Heavy Vehicles, %	2	1	2	1	0	3
Mvmt Flow	52	73	1031	104	146	1328

Major/Minor	Minor1	Major1	Major2
Conflicting Flow All	2039	568	0
Stage 1	1083	-	-
Stage 2	956	-	-
Critical Hdwy	6.84	6.92	-
Critical Hdwy Stg 1	5.84	-	-
Critical Hdwy Stg 2	5.84	-	-
Follow-up Hdwy	3.52	3.31	-
Pot Cap-1 Maneuver	~ 49	469	-
Stage 1	286	-	-
Stage 2	334	-	-
Platoon blocked, %		-	-
Mov Cap-1 Maneuver	~ 38	469	-
Mov Cap-2 Maneuver	~ 38	-	-
Stage 1	286	-	-
Stage 2	256	-	-

Approach	WB	NB	SB
HCM Control Delay, s	191.1	0	1.2
HCM LOS	F		

Minor Lane/Major Mvmt	NBT	NBRWBLn1	WBLn2	SBL	SBT
Capacity (veh/h)	-	-	38	469	623
HCM Lane V/C Ratio	-	-	1.371	0.155	0.234
HCM Control Delay (s)	-	-	\$ 438.8	14.1	12.5
HCM Lane LOS	-	-	F	B	B
HCM 95th %tile Q(veh)	-	-	5.4	0.5	0.9

**Notes**

~: Volume exceeds capacity    \$: Delay exceeds 300s    +: Computation Not Defined    \*: All major volume in platoon

HCM 2010 TWSC  
4: Sequoia Pkwy & Hazeldell Way

04/08/2020

Intersection												
Int Delay, s/veh	29.1											
Movement	EBL	EBT	EBR	WBL	WBT	WBR	NBL	NBT	NBR	SBL	SBT	SBR
Lane Configurations	↵	↵		↵	↵		↵	↵		↵	↵↵	↵
Traffic Vol, veh/h	275	25	15	15	30	85	65	115	5	80	120	55
Future Vol, veh/h	275	25	15	15	30	85	65	115	5	80	120	55
Conflicting Peds, #/hr	0	0	0	0	0	0	0	0	0	0	0	0
Sign Control	Stop	Stop	Stop	Stop	Stop	Stop	Free	Free	Free	Free	Free	Free
RT Channelized	-	-	None	-	-	None	-	-	None	-	-	Free
Storage Length	0	-	80	120	-	-	150	-	-	130	-	130
Veh in Median Storage, #	-	0	-	-	0	-	-	0	-	-	0	-
Grade, %	-	0	-	-	0	-	-	0	-	-	0	-
Peak Hour Factor	95	95	95	95	95	95	95	95	95	95	95	95
Heavy Vehicles, %	1	0	0	0	0	2	0	2	0	3	2	0
Mvmt Flow	289	26	16	16	32	89	68	121	5	84	126	58

Major/Minor	Minor2		Minor1		Major1		Major2					
Conflicting Flow All	616	558	63	506	556	124	126	0	0	126	0	0
Stage 1	295	295	-	261	261	-	-	-	-	-	-	-
Stage 2	321	263	-	245	295	-	-	-	-	-	-	-
Critical Hdwy	7.315	6.5	6.9	7.3	6.5	6.23	4.1	-	-	4.145	-	-
Critical Hdwy Stg 1	6.515	5.5	-	6.1	5.5	-	-	-	-	-	-	-
Critical Hdwy Stg 2	6.115	5.5	-	6.5	5.5	-	-	-	-	-	-	-
Follow-up Hdwy	3.5095	4	3.3	3.5	4	3.319	2.2	-	-	2.2285	-	-
Pot Cap-1 Maneuver	390	441	995	467	442	926	1473	-	-	1452	-	0
Stage 1	692	673	-	748	696	-	-	-	-	-	-	0
Stage 2	693	694	-	743	673	-	-	-	-	-	-	0
Platoon blocked, %								-	-	-	-	-
Mov Cap-1 Maneuver	306	396	995	403	397	926	1473	-	-	1452	-	-
Mov Cap-2 Maneuver	306	396	-	403	397	-	-	-	-	-	-	-
Stage 1	660	634	-	713	664	-	-	-	-	-	-	-
Stage 2	569	662	-	660	634	-	-	-	-	-	-	-

Approach	EB		WB		NB		SB	
HCM Control Delay, s	68.3		11.7		2.7		3.1	
HCM LOS	F		B					

Minor Lane/Major Mvmt	NBL	NBT	NBR	EBLn1	EBLn2	WBLn1	WBLn2	SBL	SBT
Capacity (veh/h)	1473	-	-	306	511	403	687	1452	-
HCM Lane V/C Ratio	0.046	-	-	0.946	0.082	0.039	0.176	0.058	-
HCM Control Delay (s)	7.6	-	-	76.4	12.7	14.3	11.4	7.6	-
HCM Lane LOS	A	-	-	F	B	B	B	A	-
HCM 95th %tile Q(veh)	0.1	-	-	9.4	0.3	0.1	0.6	0.2	-

Intersection						
Int Delay, s/veh	0.5					
Movement	WBL	WBR	NBT	NBR	SBL	SBT
Lane Configurations	↔		↔		↔	↔
Traffic Vol, veh/h	10	5	115	5	5	265
Future Vol, veh/h	10	5	115	5	5	265
Conflicting Peds, #/hr	0	0	0	0	0	0
Sign Control	Stop	Stop	Free	Free	Free	Free
RT Channelized	-	None	-	None	-	None
Storage Length	0	-	-	-	500	-
Veh in Median Storage, #	0	-	0	-	-	0
Grade, %	0	-	0	-	-	0
Peak Hour Factor	84	84	84	84	84	84
Heavy Vehicles, %	0	0	1	17	0	1
Mvmt Flow	12	6	137	6	6	315

Major/Minor	Minor1	Major1	Major2			
Conflicting Flow All	467	140	0	0	143	0
Stage 1	140	-	-	-	-	-
Stage 2	327	-	-	-	-	-
Critical Hdwy	6.4	6.2	-	-	4.1	-
Critical Hdwy Stg 1	5.4	-	-	-	-	-
Critical Hdwy Stg 2	5.4	-	-	-	-	-
Follow-up Hdwy	3.5	3.3	-	-	2.2	-
Pot Cap-1 Maneuver	558	913	-	-	1452	-
Stage 1	892	-	-	-	-	-
Stage 2	735	-	-	-	-	-
Platoon blocked, %			-	-	-	-
Mov Cap-1 Maneuver	556	913	-	-	1452	-
Mov Cap-2 Maneuver	613	-	-	-	-	-
Stage 1	892	-	-	-	-	-
Stage 2	732	-	-	-	-	-

Approach	WB	NB	SB
HCM Control Delay, s	10.4	0	0.1
HCM LOS	B		

Minor Lane/Major Mvmt	NBT	NBRWBLn1	SBL	SBT
Capacity (veh/h)	-	-	688	1452
HCM Lane V/C Ratio	-	-	0.026	0.004
HCM Control Delay (s)	-	-	10.4	7.5
HCM Lane LOS	-	-	B	A
HCM 95th %tile Q(veh)	-	-	0.1	0

Intersection						
Int Delay, s/veh	1.3					
Movement	EBT	EBR	WBL	WBT	NBL	NBR
Lane Configurations						
Traffic Vol, veh/h	60	0	5	45	0	15
Future Vol, veh/h	60	0	5	45	0	15
Conflicting Peds, #/hr	0	0	0	0	0	0
Sign Control	Free	Free	Free	Free	Stop	Stop
RT Channelized	-	None	-	None	-	None
Storage Length	-	-	-	-	0	-
Veh in Median Storage, #	0	-	-	0	0	-
Grade, %	0	-	-	0	0	-
Peak Hour Factor	86	86	86	86	86	86
Heavy Vehicles, %	3	0	14	0	0	8
Mvmt Flow	70	0	6	52	0	17

Major/Minor	Major1	Major2	Minor1	Minor2	Minor3
Conflicting Flow All	0	0	70	0	134
Stage 1	-	-	-	-	70
Stage 2	-	-	-	-	64
Critical Hdwy	-	-	4.24	-	6.4
Critical Hdwy Stg 1	-	-	-	-	5.4
Critical Hdwy Stg 2	-	-	-	-	5.4
Follow-up Hdwy	-	-	2.326	-	3.5
Pot Cap-1 Maneuver	-	-	1458	-	864
Stage 1	-	-	-	-	958
Stage 2	-	-	-	-	964
Platoon blocked, %	-	-	-	-	-
Mov Cap-1 Maneuver	-	-	1458	-	861
Mov Cap-2 Maneuver	-	-	-	-	861
Stage 1	-	-	-	-	958
Stage 2	-	-	-	-	960

Approach	EB	WB	NB
HCM Control Delay, s	0	0.7	8.8
HCM LOS			A

Minor Lane/Major Mvmt	NBLn1	EBT	EBR	WBL	WBT
Capacity (veh/h)	976	-	-	1458	-
HCM Lane V/C Ratio	0.018	-	-	0.004	-
HCM Control Delay (s)	8.8	-	-	7.5	0
HCM Lane LOS	A	-	-	A	A
HCM 95th %tile Q(veh)	0.1	-	-	0	-



Intersection						
Int Delay, s/veh	5					
Movement	EBT	EBR	WBL	WBT	NBL	NBR
Lane Configurations						
Traffic Vol, veh/h	70	5	125	45	5	55
Future Vol, veh/h	70	5	125	45	5	55
Conflicting Peds, #/hr	0	0	0	0	0	0
Sign Control	Free	Free	Free	Free	Stop	Stop
RT Channelized	-	None	-	None	-	None
Storage Length	-	-	-	-	0	-
Veh in Median Storage, #	0	-	-	0	0	-
Grade, %	0	-	-	0	0	-
Peak Hour Factor	86	86	86	86	86	86
Heavy Vehicles, %	3	20	0	3	0	0
Mvmt Flow	81	6	145	52	6	64

Major/Minor	Major1	Major2	Minor1		
Conflicting Flow All	0	0	87	0	426 84
Stage 1	-	-	-	-	84 -
Stage 2	-	-	-	-	342 -
Critical Hdwy	-	-	4.1	-	6.4 6.2
Critical Hdwy Stg 1	-	-	-	-	5.4 -
Critical Hdwy Stg 2	-	-	-	-	5.4 -
Follow-up Hdwy	-	-	2.2	-	3.5 3.3
Pot Cap-1 Maneuver	-	-	1522	-	589 981
Stage 1	-	-	-	-	944 -
Stage 2	-	-	-	-	724 -
Platoon blocked, %	-	-	-	-	-
Mov Cap-1 Maneuver	-	-	1522	-	531 981
Mov Cap-2 Maneuver	-	-	-	-	531 -
Stage 1	-	-	-	-	944 -
Stage 2	-	-	-	-	653 -

Approach	EB	WB	NB
HCM Control Delay, s	0	5.6	9.3
HCM LOS			A

Minor Lane/Major Mvmt	NBLn1	EBT	EBR	WBL	WBT
Capacity (veh/h)	916	-	-	1522	-
HCM Lane V/C Ratio	0.076	-	-	0.095	-
HCM Control Delay (s)	9.3	-	-	7.6	0
HCM Lane LOS	A	-	-	A	A
HCM 95th %tile Q(veh)	0.2	-	-	0.3	-

Intersection						
Int Delay, s/veh	1.3					
Movement	WBL	WBR	NBT	NBR	SBL	SBT
Lane Configurations	W	W	T	T	T	T
Traffic Vol, veh/h	15	15	90	35	15	155
Future Vol, veh/h	15	15	90	35	15	155
Conflicting Peds, #/hr	0	0	0	0	0	0
Sign Control	Stop	Stop	Free	Free	Free	Free
RT Channelized	-	None	-	None	-	None
Storage Length	0	-	-	-	-	-
Veh in Median Storage, #	0	-	0	-	-	0
Grade, %	0	-	0	-	-	0
Peak Hour Factor	89	89	89	89	89	89
Heavy Vehicles, %	13	0	1	6	7	5
Mvmt Flow	17	17	101	39	17	174

Major/Minor	Minor1	Major1	Major2		
Conflicting Flow All	329	121	0	0	140
Stage 1	121	-	-	-	-
Stage 2	208	-	-	-	-
Critical Hdwy	6.53	6.2	-	-	4.17
Critical Hdwy Stg 1	5.53	-	-	-	-
Critical Hdwy Stg 2	5.53	-	-	-	-
Follow-up Hdwy	3.617	3.3	-	-	2.263
Pot Cap-1 Maneuver	644	936	-	-	1413
Stage 1	878	-	-	-	-
Stage 2	801	-	-	-	-
Platoon blocked, %					
Mov Cap-1 Maneuver	636	936	-	-	1413
Mov Cap-2 Maneuver	636	-	-	-	-
Stage 1	878	-	-	-	-
Stage 2	791	-	-	-	-























Approach	WB	NB	SB
HCM Control Delay, s	10	0	0.7
HCM LOS	B		

Minor Lane/Major Mvmt	NBT	NBRWBLn1	SBL	SBT
Capacity (veh/h)	-	-	757	1413
HCM Lane V/C Ratio	-	-	0.045	0.012
HCM Control Delay (s)	-	-	10	7.6
HCM Lane LOS	-	-	B	A
HCM 95th %tile Q(veh)	-	-	0.1	0

# HCM Signalized Intersection Capacity Analysis

## 1: OR 99E & Redwood St/Sequoia Pkwy

03/13/2020

													
Movement	EBL	EBT	EBR	WBL	WBT	WBR	NBL	NBT	NBR	SBL	SBT	SBR	
Lane Configurations													
Traffic Volume (vph)	10	15	50	190	15	80	25	730	120	90	545	5	
Future Volume (vph)	10	15	50	190	15	80	25	730	120	90	545	5	
Ideal Flow (vphpl)	1750	1750	1750	1750	1750	1750	1750	1750	1750	1750	1750	1750	
Total Lost time (s)	4.0	4.0		4.0	4.0	4.0	4.0	5.4	5.4	4.0	5.4		
Lane Util. Factor	1.00	1.00		0.97	1.00	1.00	1.00	0.95	1.00	1.00	0.95		
Frpb, ped/bikes	1.00	0.99		1.00	1.00	1.00	1.00	1.00	1.00	1.00	1.00		
Flpb, ped/bikes	1.00	1.00		1.00	1.00	1.00	1.00	1.00	1.00	1.00	1.00		
Frt	1.00	0.88		1.00	1.00	0.85	1.00	1.00	0.85	1.00	1.00		
Flt Protected	0.95	1.00		0.95	1.00	1.00	0.95	1.00	1.00	0.95	1.00		
Satd. Flow (prot)	1662	1506		3072	1750	1261	1599	3079	1444	1511	3048		
Flt Permitted	0.95	1.00		0.95	1.00	1.00	0.95	1.00	1.00	0.95	1.00		
Satd. Flow (perm)	1662	1506		3072	1750	1261	1599	3079	1444	1511	3048		
Peak-hour factor, PHF	0.90	0.90	0.90	0.90	0.90	0.90	0.90	0.90	0.90	0.90	0.90	0.90	
Adj. Flow (vph)	11	17	56	211	17	89	28	811	133	100	606	6	
RTOR Reduction (vph)	0	52	0	0	0	76	0	0	74	0	0	0	
Lane Group Flow (vph)	11	21	0	211	17	13	28	811	59	100	612	0	
Confl. Peds. (#/hr)			1	1			1					1	
Heavy Vehicles (%)	0%	0%	2%	5%	0%	18%	4%	8%	3%	10%	9%	0%	
Turn Type	Split	NA		Split	NA	Perm	Prot	NA	Perm	Prot	NA		
Protected Phases	8	8		4	4		1	6		5	2		
Permitted Phases						4			6				
Actuated Green, G (s)	5.2	5.2		10.4	10.4	10.4	2.5	32.3	32.3	7.3	37.1		
Effective Green, g (s)	5.2	5.2		10.4	10.4	10.4	2.5	32.3	32.3	7.3	37.1		
Actuated g/C Ratio	0.07	0.07		0.14	0.14	0.14	0.03	0.44	0.44	0.10	0.51		
Clearance Time (s)	4.0	4.0		4.0	4.0	4.0	4.0	5.4	5.4	4.0	5.4		
Vehicle Extension (s)	2.3	2.3		2.3	2.3	2.3	2.3	5.5	5.5	2.3	5.5		
Lane Grp Cap (vph)	119	107		440	250	180	55	1369	642	151	1557		
v/s Ratio Prot	0.01	c0.01		c0.07	0.01		0.02	c0.26		c0.07	0.20		
v/s Ratio Perm						0.01			0.04				
v/c Ratio	0.09	0.20		0.48	0.07	0.07	0.51	0.59	0.09	0.66	0.39		
Uniform Delay, d1	31.5	31.7		28.6	26.9	26.9	34.4	15.2	11.7	31.5	10.9		
Progression Factor	1.00	1.00		1.00	1.00	1.00	1.00	1.00	1.00	1.00	1.00		
Incremental Delay, d2	0.2	0.5		0.5	0.1	0.1	4.3	1.2	0.2	8.9	0.4		
Delay (s)	31.7	32.3		29.1	27.0	27.0	38.7	16.4	11.8	40.4	11.3		
Level of Service	C	C		C	C	C	D	B	B	D	B		
Approach Delay (s)		32.2			28.4			16.4			15.4		
Approach LOS		C			C			B			B		
<b>Intersection Summary</b>													
HCM 2000 Control Delay			18.5		HCM 2000 Level of Service					B			
HCM 2000 Volume to Capacity ratio			0.54										
Actuated Cycle Length (s)			72.6		Sum of lost time (s)					17.4			
Intersection Capacity Utilization			51.0%		ICU Level of Service					A			
Analysis Period (min)			15										

c Critical Lane Group

HCM Signalized Intersection Capacity Analysis  
 2: OR 99 E & NE Territorial Rd/SE Territorial Rd

03/13/2020



Movement	EBL	EBT	EBR	WBL	WBT	WBR	NBL	NBT	NBR	SBL	SBT	SBR
Lane Configurations	↖	↗		↖	↗		↖	↕		↖	↗	↖
Traffic Volume (vph)	230	15	20	20	10	5	10	890	10	5	650	75
Future Volume (vph)	230	15	20	20	10	5	10	890	10	5	650	75
Ideal Flow (vphpl)	1750	1750	1750	1750	1750	1750	1750	1750	1750	1750	1750	1750
Total Lost time (s)	4.5	4.5		4.5	4.5		4.0	6.0		4.0	6.0	6.0
Lane Util. Factor	1.00	1.00		1.00	1.00		1.00	0.95		1.00	0.95	1.00
Frt	1.00	0.92		1.00	0.95		1.00	1.00		1.00	1.00	0.85
Flt Protected	0.95	1.00		0.95	1.00		0.95	1.00		0.95	1.00	1.00
Satd. Flow (prot)	1646	1549		1583	1395		1458	3105		950	3167	1444
Flt Permitted	0.75	1.00		0.73	1.00		0.95	1.00		0.95	1.00	1.00
Satd. Flow (perm)	1293	1549		1219	1395		1458	3105		950	3167	1444
Peak-hour factor, PHF	0.89	0.89	0.89	0.89	0.89	0.89	0.89	0.89	0.89	0.89	0.89	0.89
Adj. Flow (vph)	258	17	22	22	11	6	11	1000	11	6	730	84
RTOR Reduction (vph)	0	15	0	0	4	0	0	1	0	0	0	45
Lane Group Flow (vph)	258	24	0	22	13	0	11	1010	0	6	730	39
Heavy Vehicles (%)	1%	0%	6%	5%	11%	33%	14%	7%	0%	75%	5%	3%
Turn Type	Perm	NA		Perm	NA		Prot	NA		Prot	NA	Perm
Protected Phases		8			4		1	6		5	2	
Permitted Phases	8			4								2
Actuated Green, G (s)	23.4	23.4		23.4	23.4		1.0	33.3		1.0	33.3	33.3
Effective Green, g (s)	23.4	23.4		23.4	23.4		1.0	33.3		1.0	33.3	33.3
Actuated g/C Ratio	0.32	0.32		0.32	0.32		0.01	0.46		0.01	0.46	0.46
Clearance Time (s)	4.5	4.5		4.5	4.5		4.0	6.0		4.0	6.0	6.0
Vehicle Extension (s)	2.5	2.5		2.5	2.5		2.3	5.4		2.3	5.4	5.4
Lane Grp Cap (vph)	419	502		395	452		20	1432		13	1460	666
v/s Ratio Prot		0.02			0.01		c0.01	c0.33		0.01	0.23	
v/s Ratio Perm	c0.20			0.02								0.03
v/c Ratio	0.62	0.05		0.06	0.03		0.55	0.71		0.46	0.50	0.06
Uniform Delay, d1	20.6	16.8		16.8	16.6		35.4	15.5		35.3	13.6	10.8
Progression Factor	1.00	1.00		1.00	1.00		1.00	1.00		1.00	1.00	1.00
Incremental Delay, d2	2.3	0.0		0.0	0.0		21.1	2.2		14.3	0.6	0.1
Delay (s)	22.9	16.8		16.8	16.7		56.5	17.7		49.7	14.3	10.9
Level of Service	C	B		B	B		E	B		D	B	B
Approach Delay (s)		22.1			16.8			18.1			14.2	
Approach LOS		C			B			B			B	

Intersection Summary		
HCM 2000 Control Delay	17.1	HCM 2000 Level of Service
HCM 2000 Volume to Capacity ratio	0.67	B
Actuated Cycle Length (s)	72.2	Sum of lost time (s)
Intersection Capacity Utilization	56.3%	14.5
Analysis Period (min)	15	ICU Level of Service
c Critical Lane Group		B



Intersection						
Int Delay, s/veh	15.6					
Movement	WBL	WBR	NBT	NBR	SBL	SBT
Lane Configurations	↙	↗	↕		↙	↕
Traffic Vol, veh/h	75	140	1050	60	60	650
Future Vol, veh/h	75	140	1050	60	60	650
Conflicting Peds, #/hr	0	0	0	0	0	0
Sign Control	Stop	Stop	Free	Free	Free	Free
RT Channelized	-	None	-	None	-	None
Storage Length	0	0	-	-	340	-
Veh in Median Storage, #	0	-	0	-	-	0
Grade, %	0	-	0	-	-	0
Peak Hour Factor	86	86	86	86	86	86
Heavy Vehicles, %	7	0	7	2	5	6
Mvmt Flow	87	163	1221	70	70	756

Major/Minor	Minor1	Major1	Major2		
Conflicting Flow All	1774	646	0	0	1291
Stage 1	1256	-	-	-	-
Stage 2	518	-	-	-	-
Critical Hdwy	6.94	6.9	-	-	4.2
Critical Hdwy Stg 1	5.94	-	-	-	-
Critical Hdwy Stg 2	5.94	-	-	-	-
Follow-up Hdwy	3.57	3.3	-	-	2.25
Pot Cap-1 Maneuver	~ 70	419	-	-	517
Stage 1	222	-	-	-	-
Stage 2	549	-	-	-	-
Platoon blocked, %					
Mov Cap-1 Maneuver	~ 61	419	-	-	517
Mov Cap-2 Maneuver	~ 61	-	-	-	-
Stage 1	222	-	-	-	-
Stage 2	475	-	-	-	-

Approach	WB	NB	SB
HCM Control Delay, s	144.2	0	1.1
HCM LOS	F		























Minor Lane/Major Mvmt	NBT	NBRWBLn1	WBLn2	SBL	SBT
Capacity (veh/h)	-	-	61	419	517
HCM Lane V/C Ratio	-	-	1.43	0.389	0.135
HCM Control Delay (s)	-	-	\$ 378.2	18.9	13
HCM Lane LOS	-	-	F	C	B
HCM 95th %tile Q(veh)	-	-	7.6	1.8	0.5

Notes  
 ~: Volume exceeds capacity    \$: Delay exceeds 300s    +: Computation Not Defined    \*: All major volume in platoon

# HCM Signalized Intersection Capacity Analysis

## 4: Sequoia Pkwy & Hazeldell Way

03/13/2020

												
Movement	EBL	EBT	EBR	WBL	WBT	WBR	NBL	NBT	NBR	SBL	SBT	SBR
Lane Configurations												
Traffic Volume (vph)	90	10	30	5	20	85	20	110	10	110	95	20
Future Volume (vph)	90	10	30	5	20	85	20	110	10	110	95	20
Ideal Flow (vphpl)	1750	1750	1750	1750	1750	1750	1750	1750	1750	1750	1750	1750
Total Lost time (s)	4.0	4.0	4.0	4.0	4.0		4.0	4.0		4.0	4.0	
Lane Util. Factor	1.00	1.00	1.00	1.00	1.00		1.00	1.00		1.00	1.00	
Frpb, ped/bikes	1.00	1.00	1.00	1.00	0.98		1.00	1.00		1.00	1.00	
Flpb, ped/bikes	1.00	1.00	1.00	1.00	1.00		1.00	1.00		1.00	1.00	
Frt	1.00	1.00	0.85	1.00	0.88		1.00	0.99		1.00	0.97	
Flt Protected	0.95	1.00	1.00	0.95	1.00		0.95	1.00		0.95	1.00	
Satd. Flow (prot)	1614	1750	1488	1662	1437		1511	1570		1662	1490	
Flt Permitted	0.95	1.00	1.00	0.95	1.00		0.95	1.00		0.95	1.00	
Satd. Flow (perm)	1614	1750	1488	1662	1437		1511	1570		1662	1490	
Peak-hour factor, PHF	0.89	0.89	0.89	0.89	0.89	0.89	0.89	0.89	0.89	0.89	0.89	0.89
Adj. Flow (vph)	101	11	34	6	22	96	22	124	11	124	107	22
RTOR Reduction (vph)	0	0	27	0	86	0	0	3	0	0	6	0
Lane Group Flow (vph)	101	11	7	6	32	0	22	132	0	124	123	0
Confl. Peds. (#/hr)	3					3						
Heavy Vehicles (%)	3%	0%	0%	0%	0%	6%	10%	10%	11%	0%	16%	7%
Turn Type	Prot	NA	Perm	Prot	NA		Prot	NA		Prot	NA	
Protected Phases	7	4		3	8		5	2		1	6	
Permitted Phases			4									
Actuated Green, G (s)	7.0	11.5	11.5	1.0	5.5		1.3	16.6		8.3	23.6	
Effective Green, g (s)	7.0	11.5	11.5	1.0	5.5		1.3	16.6		8.3	23.6	
Actuated g/C Ratio	0.13	0.22	0.22	0.02	0.10		0.02	0.31		0.16	0.44	
Clearance Time (s)	4.0	4.0	4.0	4.0	4.0		4.0	4.0		4.0	4.0	
Vehicle Extension (s)	3.0	3.0	3.0	3.0	3.0		3.0	3.0		3.0	3.0	
Lane Grp Cap (vph)	211	376	320	31	148		36	488		258	658	
v/s Ratio Prot	c0.06	0.01		0.00	c0.02		0.01	c0.08		c0.07	0.08	
v/s Ratio Perm			0.00									
v/c Ratio	0.48	0.03	0.02	0.19	0.22		0.61	0.27		0.48	0.19	
Uniform Delay, d1	21.5	16.5	16.5	25.8	22.0		25.8	13.8		20.6	9.1	
Progression Factor	1.00	1.00	1.00	1.00	1.00		1.00	1.00		1.00	1.00	
Incremental Delay, d2	1.7	0.0	0.0	3.0	0.7		27.0	0.3		1.4	0.1	
Delay (s)	23.2	16.6	16.5	28.8	22.7		52.8	14.1		22.0	9.2	
Level of Service	C	B	B	C	C		D	B		C	A	
Approach Delay (s)		21.2			23.0			19.6			15.5	
Approach LOS		C			C			B			B	
<b>Intersection Summary</b>												
HCM 2000 Control Delay			19.0			HCM 2000 Level of Service				B		
HCM 2000 Volume to Capacity ratio			0.35									
Actuated Cycle Length (s)			53.4			Sum of lost time (s)			16.0			
Intersection Capacity Utilization			32.0%			ICU Level of Service			A			
Analysis Period (min)			15									
c	Critical Lane Group											

Intersection						
Int Delay, s/veh	1.5					
Movement	WBL	WBR	NBT	NBR	SBL	SBT
Lane Configurations	W		T			T
Traffic Vol, veh/h	10	15	100	5	10	75
Future Vol, veh/h	10	15	100	5	10	75
Conflicting Peds, #/hr	1	0	0	0	0	0
Sign Control	Stop	Stop	Free	Free	Free	Free
RT Channelized	-	None	-	None	-	None
Storage Length	0	-	-	-	-	-
Veh in Median Storage, #	0	-	0	-	-	0
Grade, %	0	-	0	-	-	0
Peak Hour Factor	88	88	92	92	92	92
Heavy Vehicles, %	20	20	6	0	30	3
Mvmt Flow	11	17	109	5	11	82

Major/Minor	Minor1	Major1	Major2			
Conflicting Flow All	217	112	0	0	114	0
Stage 1	112	-	-	-	-	-
Stage 2	105	-	-	-	-	-
Critical Hdwy	6.6	6.4	-	-	4.4	-
Critical Hdwy Stg 1	5.6	-	-	-	-	-
Critical Hdwy Stg 2	5.6	-	-	-	-	-
Follow-up Hdwy	3.68	3.48	-	-	2.47	-
Pot Cap-1 Maneuver	733	894	-	-	1318	-
Stage 1	870	-	-	-	-	-
Stage 2	876	-	-	-	-	-
Platoon blocked, %			-	-		-
Mov Cap-1 Maneuver	726	894	-	-	1318	-
Mov Cap-2 Maneuver	728	-	-	-	-	-
Stage 1	870	-	-	-	-	-
Stage 2	867	-	-	-	-	-

Approach	WB	NB	SB
HCM Control Delay, s	9.6	0	0.9
HCM LOS	A		

Minor Lane/Major Mvmt	NBT	NBRWBLn1	SBL	SBT
Capacity (veh/h)	-	-	819	1318
HCM Lane V/C Ratio	-	-	0.035	0.008
HCM Control Delay (s)	-	-	9.6	7.8
HCM Lane LOS	-	-	A	A
HCM 95th %tile Q(veh)	-	-	0.1	0

Intersection						
Int Delay, s/veh	1.8					
Movement	EBT	EBR	WBL	WBT	NBL	NBR
Lane Configurations						
Traffic Vol, veh/h	10	0	15	55	0	5
Future Vol, veh/h	10	0	15	55	0	5
Conflicting Peds, #/hr	0	0	0	0	0	0
Sign Control	Free	Free	Free	Free	Stop	Stop
RT Channelized	-	None	-	None	-	None
Storage Length	-	-	-	-	0	-
Veh in Median Storage, #	0	-	-	0	0	-
Grade, %	0	-	-	0	0	-
Peak Hour Factor	87	87	87	87	87	87
Heavy Vehicles, %	11	100	0	2	0	33
Mvmt Flow	11	0	17	63	0	6

Major/Minor	Major1	Major2	Minor1	Minor2	Minor3
Conflicting Flow All	0	0	11	0	108
Stage 1	-	-	-	-	11
Stage 2	-	-	-	-	97
Critical Hdwy	-	-	4.1	-	6.4
Critical Hdwy Stg 1	-	-	-	-	5.4
Critical Hdwy Stg 2	-	-	-	-	5.4
Follow-up Hdwy	-	-	2.2	-	3.5
Pot Cap-1 Maneuver	-	-	1621	-	894
Stage 1	-	-	-	-	1017
Stage 2	-	-	-	-	932
Platoon blocked, %	-	-	-	-	-
Mov Cap-1 Maneuver	-	-	1621	-	884
Mov Cap-2 Maneuver	-	-	-	-	884
Stage 1	-	-	-	-	1017
Stage 2	-	-	-	-	922

Approach	EB	WB	NB
HCM Control Delay, s	0	1.6	8.7
HCM LOS			A

Minor Lane/Major Mvmt	NBLn1	EBT	EBR	WBL	WBT
Capacity (veh/h)	986	-	-	1621	-
HCM Lane V/C Ratio	0.006	-	-	0.011	-
HCM Control Delay (s)	8.7	-	-	7.2	0
HCM Lane LOS	A	-	-	A	A
HCM 95th %tile Q(veh)	0	-	-	0	-



Intersection						
Int Delay, s/veh	5.9					
Movement	EBT	EBR	WBL	WBT	NBL	NBR
Lane Configurations						
Traffic Vol, veh/h	10	5	45	60	10	110
Future Vol, veh/h	10	5	45	60	10	110
Conflicting Peds, #/hr	0	0	0	0	0	0
Sign Control	Free	Free	Free	Free	Stop	Stop
RT Channelized	-	None	-	None	-	None
Storage Length	-	-	-	-	0	-
Veh in Median Storage, #	0	-	-	0	0	-
Grade, %	0	-	-	0	0	-
Peak Hour Factor	82	82	82	82	82	82
Heavy Vehicles, %	18	0	0	4	0	0
Mvmt Flow	12	6	55	73	12	134

Major/Minor	Major1	Major2	Minor1		
Conflicting Flow All	0	0	18	0	198
Stage 1	-	-	-	-	15
Stage 2	-	-	-	-	183
Critical Hdwy	-	-	4.1	-	6.4
Critical Hdwy Stg 1	-	-	-	-	5.4
Critical Hdwy Stg 2	-	-	-	-	5.4
Follow-up Hdwy	-	-	2.2	-	3.5
Pot Cap-1 Maneuver	-	-	1612	-	795
Stage 1	-	-	-	-	1013
Stage 2	-	-	-	-	853
Platoon blocked, %	-	-	-	-	-
Mov Cap-1 Maneuver	-	-	1612	-	766
Mov Cap-2 Maneuver	-	-	-	-	766
Stage 1	-	-	-	-	1013
Stage 2	-	-	-	-	822

Approach	EB	WB	NB
HCM Control Delay, s	0	3.1	9
HCM LOS			A

Minor Lane/Major Mvmt	NBLn1	EBT	EBR	WBL	WBT
Capacity (veh/h)	1036	-	-	1612	-
HCM Lane V/C Ratio	0.141	-	-	0.034	-
HCM Control Delay (s)	9	-	-	7.3	0
HCM Lane LOS	A	-	-	A	A
HCM 95th %tile Q(veh)	0.5	-	-	0.1	-

Intersection						
Int Delay, s/veh	2.3					
Movement	WBL	WBR	NBT	NBR	SBL	SBT
Lane Configurations						
Traffic Vol, veh/h	30	25	110	10	5	75
Future Vol, veh/h	30	25	110	10	5	75
Conflicting Peds, #/hr	0	0	0	0	0	0
Sign Control	Stop	Stop	Free	Free	Free	Free
RT Channelized	-	None	-	None	-	None
Storage Length	0	-	-	-	-	-
Veh in Median Storage, #	0	-	0	-	-	0
Grade, %	0	-	0	-	-	0
Peak Hour Factor	89	89	89	89	89	89
Heavy Vehicles, %	10	0	3	17	0	4
Mvmt Flow	34	28	124	11	6	84

Major/Minor	Minor1	Major1	Major2		
Conflicting Flow All	226	130	0	0	135
Stage 1	130	-	-	-	-
Stage 2	96	-	-	-	-
Critical Hdwy	6.5	6.2	-	-	4.1
Critical Hdwy Stg 1	5.5	-	-	-	-
Critical Hdwy Stg 2	5.5	-	-	-	-
Follow-up Hdwy	3.59	3.3	-	-	2.2
Pot Cap-1 Maneuver	745	925	-	-	1462
Stage 1	877	-	-	-	-
Stage 2	908	-	-	-	-
Platoon blocked, %			-	-	-
Mov Cap-1 Maneuver	742	925	-	-	1462
Mov Cap-2 Maneuver	742	-	-	-	-
Stage 1	877	-	-	-	-
Stage 2	904	-	-	-	-

Approach	WB	NB	SB
HCM Control Delay, s	9.8	0	0.5
HCM LOS	A		

Minor Lane/Major Mvmt	NBT	NBRWBLn1	SBL	SBT
Capacity (veh/h)	-	-	815	1462
HCM Lane V/C Ratio	-	-	0.076	0.004
HCM Control Delay (s)	-	-	9.8	7.5
HCM Lane LOS	-	-	A	A
HCM 95th %tile Q(veh)	-	-	0.2	0

# HCM Signalized Intersection Capacity Analysis

## 1: OR 99E & Redwood St/Sequoia Pkwy

04/08/2020



Movement	EBL	EBT	EBR	WBL	WBT	WBR	NBL	NBT	NBR	SBL	SBT	SBR
Lane Configurations	↖	↗		↖↗	↑	↖	↖	↑↑	↖	↖	↗↖	
Traffic Volume (vph)	5	70	40	360	60	130	60	765	135	140	1015	20
Future Volume (vph)	5	70	40	360	60	130	60	765	135	140	1015	20
Ideal Flow (vphp)	1750	1750	1750	1750	1750	1750	1750	1750	1750	1750	1750	1750
Total Lost time (s)	4.0	4.0		4.0	4.0	4.0	4.0	5.4	5.4	4.0	5.4	
Lane Util. Factor	1.00	1.00		0.97	1.00	1.00	1.00	0.95	1.00	1.00	0.95	
Frt	1.00	0.95		1.00	1.00	0.85	1.00	1.00	0.85	1.00	1.00	
Flt Protected	0.95	1.00		0.95	1.00	1.00	0.95	1.00	1.00	0.95	1.00	
Satd. Flow (prot)	1662	1615		3193	1750	1430	1599	3167	1430	1646	3190	
Flt Permitted	0.95	1.00		0.95	1.00	1.00	0.95	1.00	1.00	0.95	1.00	
Satd. Flow (perm)	1662	1615		3193	1750	1430	1599	3167	1430	1646	3190	
Peak-hour factor, PHF	0.91	0.91	0.91	0.91	0.91	0.91	0.91	0.91	0.91	0.91	0.91	0.91
Adj. Flow (vph)	5	77	44	396	66	143	66	841	148	154	1115	22
RTOR Reduction (vph)	0	20	0	0	0	120	0	0	87	0	1	0
Lane Group Flow (vph)	5	101	0	396	66	23	66	841	61	154	1136	0
Heavy Vehicles (%)	0%	1%	5%	1%	0%	4%	4%	5%	4%	1%	4%	0%
Turn Type	Split	NA		Split	NA	Perm	Prot	NA	Perm	Prot	NA	
Protected Phases	8	8		4	4		1	6		5	2	
Permitted Phases						4			6			
Actuated Green, G (s)	10.5	10.5		14.6	14.6	14.6	6.9	37.7	37.7	11.0	41.8	
Effective Green, g (s)	10.5	10.5		14.6	14.6	14.6	6.9	37.7	37.7	11.0	41.8	
Actuated g/C Ratio	0.12	0.12		0.16	0.16	0.16	0.08	0.41	0.41	0.12	0.46	
Clearance Time (s)	4.0	4.0		4.0	4.0	4.0	4.0	5.4	5.4	4.0	5.4	
Vehicle Extension (s)	2.3	2.3		2.3	2.3	2.3	2.3	5.5	5.5	2.3	5.5	
Lane Grp Cap (vph)	191	185		511	280	228	120	1309	591	198	1462	
v/s Ratio Prot	0.00	c0.06		c0.12	0.04		0.04	0.27		c0.09	c0.36	
v/s Ratio Perm						0.02			0.04			
v/c Ratio	0.03	0.54		0.77	0.24	0.10	0.55	0.64	0.10	0.78	0.78	
Uniform Delay, d1	35.8	38.1		36.7	33.4	32.7	40.7	21.4	16.4	38.9	20.8	
Progression Factor	1.00	1.00		1.00	1.00	1.00	1.00	1.00	1.00	1.00	1.00	
Incremental Delay, d2	0.0	2.2		6.8	0.3	0.1	3.8	1.6	0.2	16.4	3.2	
Delay (s)	35.8	40.3		43.5	33.7	32.8	44.5	23.0	16.6	55.3	24.0	
Level of Service	D	D		D	C	C	D	C	B	E	C	
Approach Delay (s)		40.2			39.9			23.4			27.8	
Approach LOS		D			D			C			C	

Intersection Summary		
HCM 2000 Control Delay	29.2	HCM 2000 Level of Service
HCM 2000 Volume to Capacity ratio	0.77	C
Actuated Cycle Length (s)	91.2	Sum of lost time (s)
Intersection Capacity Utilization	63.7%	17.4
Analysis Period (min)	15	ICU Level of Service
c Critical Lane Group		B

HCM Signalized Intersection Capacity Analysis  
 2: OR 99 E & NE Territorial Rd/SE Territorial Rd

03/13/2020



Movement	EBL	EBT	EBR	WBL	WBT	WBR	NBL	NBT	NBR	SBL	SBT	SBR
Lane Configurations												
Traffic Volume (vph)	185	20	25	15	30	5	30	985	15	5	1070	260
Future Volume (vph)	185	20	25	15	30	5	30	985	15	5	1070	260
Ideal Flow (vphpl)	1750	1750	1750	1750	1750	1750	1750	1750	1750	1750	1750	1750
Total Lost time (s)	4.5	4.5		4.5	4.5		4.0	6.0		4.0	6.0	6.0
Lane Util. Factor	1.00	1.00		1.00	1.00		1.00	0.95		1.00	0.95	1.00
Frt	1.00	0.92		1.00	0.98		1.00	1.00		1.00	1.00	0.85
Flt Protected	0.95	1.00		0.95	1.00		0.95	1.00		0.95	1.00	1.00
Satd. Flow (prot)	1646	1562		1554	1714		1662	3185		1330	3167	1473
Flt Permitted	0.73	1.00		0.73	1.00		0.95	1.00		0.95	1.00	1.00
Satd. Flow (perm)	1271	1562		1188	1714		1662	3185		1330	3167	1473
Peak-hour factor, PHF	0.96	0.96	0.96	0.96	0.96	0.96	0.96	0.96	0.96	0.96	0.96	0.96
Adj. Flow (vph)	193	21	26	16	31	5	31	1026	16	5	1115	271
RTOR Reduction (vph)	0	20	0	0	4	0	0	1	0	0	0	123
Lane Group Flow (vph)	193	27	0	16	32	0	31	1041	0	5	1115	148
Heavy Vehicles (%)	1%	0%	5%	7%	0%	0%	0%	4%	15%	25%	5%	1%
Turn Type	Perm	NA		Perm	NA		Prot	NA		Prot	NA	Perm
Protected Phases		8			4		1	6		5	2	
Permitted Phases	8			4								2
Actuated Green, G (s)	18.9	18.9		18.9	18.9		3.8	47.5		0.9	44.6	44.6
Effective Green, g (s)	18.9	18.9		18.9	18.9		3.8	47.5		0.9	44.6	44.6
Actuated g/C Ratio	0.23	0.23		0.23	0.23		0.05	0.58		0.01	0.55	0.55
Clearance Time (s)	4.5	4.5		4.5	4.5		4.0	6.0		4.0	6.0	6.0
Vehicle Extension (s)	2.5	2.5		2.5	2.5		2.3	5.4		2.3	5.4	5.4
Lane Grp Cap (vph)	293	360		274	396		77	1849		14	1726	803
v/s Ratio Prot		0.02			0.02		c0.02	c0.33		0.00	c0.35	
v/s Ratio Perm	c0.15			0.01								0.10
v/c Ratio	0.66	0.08		0.06	0.08		0.40	0.56		0.36	0.65	0.18
Uniform Delay, d1	28.5	24.6		24.5	24.6		37.9	10.7		40.2	13.1	9.4
Progression Factor	1.00	1.00		1.00	1.00		1.00	1.00		1.00	1.00	1.00
Incremental Delay, d2	4.7	0.1		0.1	0.1		2.0	0.7		8.9	1.2	0.3
Delay (s)	33.2	24.7		24.6	24.7		39.9	11.4		49.0	14.3	9.7
Level of Service	C	C		C	C		D	B		D	B	A
Approach Delay (s)		31.6			24.7			12.2			13.5	
Approach LOS		C			C			B			B	

Intersection Summary		
HCM 2000 Control Delay	14.8	HCM 2000 Level of Service
HCM 2000 Volume to Capacity ratio	0.63	B
Actuated Cycle Length (s)	81.8	Sum of lost time (s)
Intersection Capacity Utilization	58.7%	14.5
Analysis Period (min)	15	ICU Level of Service
c Critical Lane Group		B



**Intersection**

Int Delay, s/veh 10.5

Movement	WBL	WBR	NBT	NBR	SBL	SBT
Lane Configurations	↘	↗	↕		↘	↗
Traffic Vol, veh/h	50	75	1020	100	140	1290
Future Vol, veh/h	50	75	1020	100	140	1290
Conflicting Peds, #/hr	0	0	0	0	0	0
Sign Control	Stop	Stop	Free	Free	Free	Free
RT Channelized	-	None	-	None	-	None
Storage Length	0	0	-	-	340	-
Veh in Median Storage, #	0	-	0	-	-	0
Grade, %	0	-	0	-	-	0
Peak Hour Factor	96	96	96	96	96	96
Heavy Vehicles, %	2	1	2	1	0	3
Mvmt Flow	52	78	1063	104	146	1344

Major/Minor	Minor1	Major1	Major2
Conflicting Flow All	2079	584	0
Stage 1	1115	-	-
Stage 2	964	-	-
Critical Hdwy	6.84	6.92	-
Critical Hdwy Stg 1	5.84	-	-
Critical Hdwy Stg 2	5.84	-	-
Follow-up Hdwy	3.52	3.31	-
Pot Cap-1 Maneuver	~ 46	457	-
Stage 1	275	-	-
Stage 2	331	-	-
Platoon blocked, %		-	-
Mov Cap-1 Maneuver	~ 35	457	-
Mov Cap-2 Maneuver	~ 35	-	-
Stage 1	275	-	-
Stage 2	251	-	-

Approach	WB	NB	SB
HCM Control Delay, s	209.6	0	1.3
HCM LOS	F		

Minor Lane/Major Mvmt	NBT	NBRWBLn1	WBLn2	SBL	SBT
Capacity (veh/h)	-	-	35	457	606
HCM Lane V/C Ratio	-	-	1.488	0.171	0.241
HCM Control Delay (s)	-	-	\$ 502.2	14.5	12.8
HCM Lane LOS	-	-	F	B	B
HCM 95th %tile Q(veh)	-	-	5.6	0.6	0.9

**Notes**

~: Volume exceeds capacity    \$: Delay exceeds 300s    +: Computation Not Defined    \*: All major volume in platoon

# HCM Signalized Intersection Capacity Analysis

## 4: Sequoia Pkwy & Hazeldell Way

04/08/2020



Movement	EBL	EBT	EBR	WBL	WBT	WBR	NBL	NBT	NBR	SBL	SBT	SBR
Lane Configurations												
Traffic Volume (vph)	275	25	15	15	30	140	65	140	5	110	125	55
Future Volume (vph)	275	25	15	15	30	140	65	140	5	110	125	55
Ideal Flow (vphp)	1750	1750	1750	1750	1750	1750	1750	1750	1750	1750	1750	1750
Total Lost time (s)	4.0	4.0	4.0	4.0	4.0		4.0	4.0		4.0	4.0	
Lane Util. Factor	1.00	1.00	1.00	1.00	1.00		1.00	1.00		1.00	1.00	
Frt	1.00	1.00	0.85	1.00	0.88		1.00	1.00		1.00	0.95	
Flt Protected	0.95	1.00	1.00	0.95	1.00		0.95	1.00		0.95	1.00	
Satd. Flow (prot)	1646	1750	1488	1662	1510		1662	1708		1614	1647	
Flt Permitted	0.95	1.00	1.00	0.95	1.00		0.95	1.00		0.95	1.00	
Satd. Flow (perm)	1646	1750	1488	1662	1510		1662	1708		1614	1647	
Peak-hour factor, PHF	0.95	0.95	0.95	0.95	0.95	0.95	0.95	0.95	0.95	0.95	0.95	0.95
Adj. Flow (vph)	289	26	16	16	32	147	68	147	5	116	132	58
RTOR Reduction (vph)	0	0	10	0	128	0	0	2	0	0	15	0
Lane Group Flow (vph)	289	26	6	16	51	0	68	150	0	116	175	0
Heavy Vehicles (%)	1%	0%	0%	0%	0%	2%	0%	2%	0%	3%	2%	0%
Turn Type	Prot	NA	Perm	Prot	NA		Prot	NA		Prot	NA	
Protected Phases	7	4		3	8		5	2		1	6	
Permitted Phases			4									
Actuated Green, G (s)	16.4	23.1	23.1	1.2	7.9		4.3	13.9		8.3	17.9	
Effective Green, g (s)	16.4	23.1	23.1	1.2	7.9		4.3	13.9		8.3	17.9	
Actuated g/C Ratio	0.26	0.37	0.37	0.02	0.13		0.07	0.22		0.13	0.29	
Clearance Time (s)	4.0	4.0	4.0	4.0	4.0		4.0	4.0		4.0	4.0	
Vehicle Extension (s)	3.0	3.0	3.0	3.0	3.0		3.0	3.0		3.0	3.0	
Lane Grp Cap (vph)	431	646	549	31	190		114	379		214	471	
v/s Ratio Prot	c0.18	0.01		0.01	c0.03		0.04	0.09		c0.07	c0.11	
v/s Ratio Perm			0.00									
v/c Ratio	0.67	0.04	0.01	0.52	0.27		0.60	0.40		0.54	0.37	
Uniform Delay, d1	20.6	12.6	12.5	30.4	24.7		28.3	20.7		25.3	17.8	
Progression Factor	1.00	1.00	1.00	1.00	1.00		1.00	1.00		1.00	1.00	
Incremental Delay, d2	4.1	0.0	0.0	13.7	0.8		8.1	0.7		2.8	0.5	
Delay (s)	24.7	12.6	12.5	44.1	25.4		36.4	21.4		28.1	18.3	
Level of Service	C	B	B	D	C		D	C		C	B	
Approach Delay (s)		23.2			27.0			26.0			22.0	
Approach LOS		C			C			C			C	

Intersection Summary		
HCM 2000 Control Delay	24.1	HCM 2000 Level of Service C
HCM 2000 Volume to Capacity ratio	0.49	
Actuated Cycle Length (s)	62.5	Sum of lost time (s) 16.0
Intersection Capacity Utilization	55.9%	ICU Level of Service B
Analysis Period (min)	15	
c Critical Lane Group		

Intersection						
Int Delay, s/veh	0.4					
Movement	WBL	WBR	NBT	NBR	SBL	SBT
Lane Configurations	W		T			T
Traffic Vol, veh/h	10	5	120	5	5	270
Future Vol, veh/h	10	5	120	5	5	270
Conflicting Peds, #/hr	0	0	0	0	0	0
Sign Control	Stop	Stop	Free	Free	Free	Free
RT Channelized	-	None	-	None	-	None
Storage Length	0	-	-	-	-	-
Veh in Median Storage, #	0	-	0	-	-	0
Grade, %	0	-	0	-	-	0
Peak Hour Factor	84	84	84	84	84	84
Heavy Vehicles, %	0	0	1	17	0	1
Mvmt Flow	12	6	143	6	6	321

Major/Minor	Minor1	Major1	Major2		
Conflicting Flow All	479	146	0	0	149
Stage 1	146	-	-	-	-
Stage 2	333	-	-	-	-
Critical Hdwy	6.4	6.2	-	-	4.1
Critical Hdwy Stg 1	5.4	-	-	-	-
Critical Hdwy Stg 2	5.4	-	-	-	-
Follow-up Hdwy	3.5	3.3	-	-	2.2
Pot Cap-1 Maneuver	549	906	-	-	1445
Stage 1	886	-	-	-	-
Stage 2	731	-	-	-	-
Platoon blocked, %			-	-	-
Mov Cap-1 Maneuver	546	906	-	-	1445
Mov Cap-2 Maneuver	606	-	-	-	-
Stage 1	886	-	-	-	-
Stage 2	727	-	-	-	-

Approach	WB	NB	SB
HCM Control Delay, s	10.4	0	0.1
HCM LOS	B		

Minor Lane/Major Mvmt	NBT	NBRWBLn1	SBL	SBT
Capacity (veh/h)	-	-	681	1445
HCM Lane V/C Ratio	-	-	0.026	0.004
HCM Control Delay (s)	-	-	10.4	7.5
HCM Lane LOS	-	-	B	A
HCM 95th %tile Q(veh)	-	-	0.1	0

**Intersection**

Int Delay, s/veh 1.2

**Movement** EBT EBR WBL WBT NBL NBR

Lane Configurations						
Traffic Vol, veh/h	70	0	5	50	0	15
Future Vol, veh/h	70	0	5	50	0	15
Conflicting Peds, #/hr	0	0	0	0	0	0
Sign Control	Free	Free	Free	Free	Stop	Stop
RT Channelized	-	None	-	None	-	None
Storage Length	-	-	-	-	0	-
Veh in Median Storage, #	0	-	-	0	0	-
Grade, %	0	-	-	0	0	-
Peak Hour Factor	86	86	86	86	86	86
Heavy Vehicles, %	3	0	14	0	0	8
Mvmt Flow	81	0	6	58	0	17

**Major/Minor** Major1 Major2 Minor1

Conflicting Flow All	0	0	81	0	151	81
Stage 1	-	-	-	-	81	-
Stage 2	-	-	-	-	70	-
Critical Hdwy	-	-	4.24	-	6.4	6.28
Critical Hdwy Stg 1	-	-	-	-	5.4	-
Critical Hdwy Stg 2	-	-	-	-	5.4	-
Follow-up Hdwy	-	-	2.326	-	3.5	3.372
Pot Cap-1 Maneuver	-	-	1444	-	846	963
Stage 1	-	-	-	-	947	-
Stage 2	-	-	-	-	958	-
Platoon blocked, %	-	-	-	-	-	-
Mov Cap-1 Maneuver	-	-	1444	-	843	963
Mov Cap-2 Maneuver	-	-	-	-	843	-
Stage 1	-	-	-	-	947	-
Stage 2	-	-	-	-	954	-

**Approach** EB WB NB

HCM Control Delay, s	0	0.7	8.8
HCM LOS			A

**Minor Lane/Major Mvmt** NBLn1 EBT EBR WBL WBT

Capacity (veh/h)	963	-	-	1444	-
HCM Lane V/C Ratio	0.018	-	-	0.004	-
HCM Control Delay (s)	8.8	-	-	7.5	0
HCM Lane LOS	A	-	-	A	A
HCM 95th %tile Q(veh)	0.1	-	-	0	-



Intersection						
Int Delay, s/veh	4.8					
Movement	EBT	EBR	WBL	WBT	NBL	NBR
Lane Configurations						
Traffic Vol, veh/h	80	5	125	50	5	55
Future Vol, veh/h	80	5	125	50	5	55
Conflicting Peds, #/hr	0	0	0	0	0	0
Sign Control	Free	Free	Free	Free	Stop	Stop
RT Channelized	-	None	-	None	-	None
Storage Length	-	-	-	-	0	-
Veh in Median Storage, #	0	-	-	0	0	-
Grade, %	0	-	-	0	0	-
Peak Hour Factor	86	86	86	86	86	86
Heavy Vehicles, %	3	20	0	3	0	0
Mvmt Flow	93	6	145	58	6	64

Major/Minor	Major1	Major2	Minor1		
Conflicting Flow All	0	0	99	0	444 96
Stage 1	-	-	-	-	96 -
Stage 2	-	-	-	-	348 -
Critical Hdwy	-	-	4.1	-	6.4 6.2
Critical Hdwy Stg 1	-	-	-	-	5.4 -
Critical Hdwy Stg 2	-	-	-	-	5.4 -
Follow-up Hdwy	-	-	2.2	-	3.5 3.3
Pot Cap-1 Maneuver	-	-	1507	-	575 966
Stage 1	-	-	-	-	933 -
Stage 2	-	-	-	-	719 -
Platoon blocked, %	-	-	-	-	-
Mov Cap-1 Maneuver	-	-	1507	-	518 966
Mov Cap-2 Maneuver	-	-	-	-	518 -
Stage 1	-	-	-	-	933 -
Stage 2	-	-	-	-	648 -

Approach	EB	WB	NB
HCM Control Delay, s	0	5.5	9.3
HCM LOS			A

Minor Lane/Major Mvmt	NBLn1	EBT	EBR	WBL	WBT
Capacity (veh/h)	901	-	-	1507	-
HCM Lane V/C Ratio	0.077	-	-	0.096	-
HCM Control Delay (s)	9.3	-	-	7.6	0
HCM Lane LOS	A	-	-	A	A
HCM 95th %tile Q(veh)	0.3	-	-	0.3	-

Intersection						
Int Delay, s/veh	1.3					
Movement	WBL	WBR	NBT	NBR	SBL	SBT
Lane Configurations	W	W	T	T	T	T
Traffic Vol, veh/h	15	15	100	35	15	160
Future Vol, veh/h	15	15	100	35	15	160
Conflicting Peds, #/hr	0	0	0	0	0	0
Sign Control	Stop	Stop	Free	Free	Free	Free
RT Channelized	-	None	-	None	-	None
Storage Length	0	-	-	-	-	-
Veh in Median Storage, #	0	-	0	-	-	0
Grade, %	0	-	0	-	-	0
Peak Hour Factor	89	89	89	89	89	89
Heavy Vehicles, %	13	0	1	6	7	5
Mvmt Flow	17	17	112	39	17	180

Major/Minor	Minor1	Major1	Major2			
Conflicting Flow All	345	132	0	0	152	0
Stage 1	132	-	-	-	-	-
Stage 2	213	-	-	-	-	-
Critical Hdwy	6.53	6.2	-	-	4.17	-
Critical Hdwy Stg 1	5.53	-	-	-	-	-
Critical Hdwy Stg 2	5.53	-	-	-	-	-
Follow-up Hdwy	3.617	3.3	-	-	2.263	-
Pot Cap-1 Maneuver	630	923	-	-	1399	-
Stage 1	868	-	-	-	-	-
Stage 2	797	-	-	-	-	-
Platoon blocked, %			-	-		
Mov Cap-1 Maneuver	622	923	-	-	1399	-
Mov Cap-2 Maneuver	622	-	-	-	-	-
Stage 1	868	-	-	-	-	-
Stage 2	787	-	-	-	-	-























Approach	WB	NB	SB
HCM Control Delay, s	10.1	0	0.7
HCM LOS	B		

Minor Lane/Major Mvmt	NBT	NBRWBLn1	SBL	SBT
Capacity (veh/h)	-	-	743	1399
HCM Lane V/C Ratio	-	-	0.045	0.012
HCM Control Delay (s)	-	-	10.1	7.6
HCM Lane LOS	-	-	B	A
HCM 95th %tile Q(veh)	-	-	0.1	0

# HCM Signalized Intersection Capacity Analysis

## 1: OR 99E & Redwood St/Sequoia Pkwy

03/13/2020

												
Movement	EBL	EBT	EBR	WBL	WBT	WBR	NBL	NBT	NBR	SBL	SBT	SBR
Lane Configurations												
Traffic Volume (vph)	10	25	50	200	15	80	25	730	160	95	545	5
Future Volume (vph)	10	25	50	200	15	80	25	730	160	95	545	5
Ideal Flow (vphpl)	1750	1750	1750	1750	1750	1750	1750	1750	1750	1750	1750	1750
Total Lost time (s)	4.0	4.0		4.0	4.0	4.0	4.0	5.4	5.4	4.0	5.4	
Lane Util. Factor	1.00	1.00		0.97	1.00	1.00	1.00	0.95	1.00	1.00	0.95	
Frbp, ped/bikes	1.00	0.99		1.00	1.00	1.00	1.00	1.00	1.00	1.00	1.00	
Flpb, ped/bikes	1.00	1.00		1.00	1.00	1.00	1.00	1.00	1.00	1.00	1.00	
Frt	1.00	0.90		1.00	1.00	0.85	1.00	1.00	0.85	1.00	1.00	
Flt Protected	0.95	1.00		0.95	1.00	1.00	0.95	1.00	1.00	0.95	1.00	
Satd. Flow (prot)	1662	1538		3072	1750	1261	1599	3079	1444	1511	3048	
Flt Permitted	0.95	1.00		0.95	1.00	1.00	0.95	1.00	1.00	0.95	1.00	
Satd. Flow (perm)	1662	1538		3072	1750	1261	1599	3079	1444	1511	3048	
Peak-hour factor, PHF	0.90	0.90	0.90	0.90	0.90	0.90	0.90	0.90	0.90	0.90	0.90	0.90
Adj. Flow (vph)	11	28	56	222	17	89	28	811	178	106	606	6
RTOR Reduction (vph)	0	52	0	0	0	76	0	0	99	0	0	0
Lane Group Flow (vph)	11	32	0	222	17	13	28	811	79	106	612	0
Confl. Peds. (#/hr)			1	1			1					1
Heavy Vehicles (%)	0%	0%	2%	5%	0%	18%	4%	8%	3%	10%	9%	0%
Turn Type	Split	NA		Split	NA	Perm	Prot	NA	Perm	Prot	NA	
Protected Phases	8	8		4	4		1	6		5	2	
Permitted Phases						4			6			
Actuated Green, G (s)	5.5	5.5		10.8	10.8	10.8	2.5	32.9	32.9	7.4	37.8	
Effective Green, g (s)	5.5	5.5		10.8	10.8	10.8	2.5	32.9	32.9	7.4	37.8	
Actuated g/C Ratio	0.07	0.07		0.15	0.15	0.15	0.03	0.44	0.44	0.10	0.51	
Clearance Time (s)	4.0	4.0		4.0	4.0	4.0	4.0	5.4	5.4	4.0	5.4	
Vehicle Extension (s)	2.3	2.3		2.3	2.3	2.3	2.3	5.5	5.5	2.3	5.5	
Lane Grp Cap (vph)	123	114		448	255	184	54	1368	641	151	1556	
v/s Ratio Prot	0.01	c0.02		c0.07	0.01		0.02	c0.26		c0.07	0.20	
v/s Ratio Perm						0.01			0.05			
v/c Ratio	0.09	0.28		0.50	0.07	0.07	0.52	0.59	0.12	0.70	0.39	
Uniform Delay, d1	31.9	32.4		29.1	27.3	27.3	35.2	15.5	12.1	32.2	11.1	
Progression Factor	1.00	1.00		1.00	1.00	1.00	1.00	1.00	1.00	1.00	1.00	
Incremental Delay, d2	0.2	0.8		0.5	0.1	0.1	5.1	1.2	0.2	12.2	0.4	
Delay (s)	32.1	33.2		29.6	27.3	27.4	40.2	16.7	12.3	44.5	11.5	
Level of Service	C	C		C	C	C	D	B	B	D	B	
Approach Delay (s)		33.1			28.9			16.5			16.4	
Approach LOS		C			C			B			B	
<b>Intersection Summary</b>												
HCM 2000 Control Delay			19.1		HCM 2000 Level of Service					B		
HCM 2000 Volume to Capacity ratio			0.56									
Actuated Cycle Length (s)			74.0		Sum of lost time (s)					17.4		
Intersection Capacity Utilization			51.7%		ICU Level of Service					A		
Analysis Period (min)			15									

c Critical Lane Group

HCM Signalized Intersection Capacity Analysis  
 2: OR 99 E & NE Territorial Rd/SE Territorial Rd

03/13/2020



Movement	EBL	EBT	EBR	WBL	WBT	WBR	NBL	NBT	NBR	SBL	SBT	SBR
Lane Configurations	↖	↗		↖	↗		↖	↕		↖	↗	↖
Traffic Volume (vph)	230	15	20	20	10	5	10	890	10	5	655	75
Future Volume (vph)	230	15	20	20	10	5	10	890	10	5	655	75
Ideal Flow (vphpl)	1750	1750	1750	1750	1750	1750	1750	1750	1750	1750	1750	1750
Total Lost time (s)	4.5	4.5		4.5	4.5		4.0	6.0		4.0	6.0	6.0
Lane Util. Factor	1.00	1.00		1.00	1.00		1.00	0.95		1.00	0.95	1.00
Frt	1.00	0.92		1.00	0.95		1.00	1.00		1.00	1.00	0.85
Flt Protected	0.95	1.00		0.95	1.00		0.95	1.00		0.95	1.00	1.00
Satd. Flow (prot)	1646	1549		1583	1395		1458	3105		950	3167	1444
Flt Permitted	0.75	1.00		0.73	1.00		0.95	1.00		0.95	1.00	1.00
Satd. Flow (perm)	1293	1549		1219	1395		1458	3105		950	3167	1444
Peak-hour factor, PHF	0.89	0.89	0.89	0.89	0.89	0.89	0.89	0.89	0.89	0.89	0.89	0.89
Adj. Flow (vph)	258	17	22	22	11	6	11	1000	11	6	736	84
RTOR Reduction (vph)	0	15	0	0	4	0	0	1	0	0	0	45
Lane Group Flow (vph)	258	24	0	22	13	0	11	1010	0	6	736	39
Heavy Vehicles (%)	1%	0%	6%	5%	11%	33%	14%	7%	0%	75%	5%	3%
Turn Type	Perm	NA		Perm	NA		Prot	NA		Prot	NA	Perm
Protected Phases		8			4		1	6		5	2	
Permitted Phases	8			4								2
Actuated Green, G (s)	23.4	23.4		23.4	23.4		1.0	33.3		1.0	33.3	33.3
Effective Green, g (s)	23.4	23.4		23.4	23.4		1.0	33.3		1.0	33.3	33.3
Actuated g/C Ratio	0.32	0.32		0.32	0.32		0.01	0.46		0.01	0.46	0.46
Clearance Time (s)	4.5	4.5		4.5	4.5		4.0	6.0		4.0	6.0	6.0
Vehicle Extension (s)	2.5	2.5		2.5	2.5		2.3	5.4		2.3	5.4	5.4
Lane Grp Cap (vph)	419	502		395	452		20	1432		13	1460	666
v/s Ratio Prot		0.02			0.01		c0.01	c0.33		0.01	0.23	
v/s Ratio Perm	c0.20			0.02								0.03
v/c Ratio	0.62	0.05		0.06	0.03		0.55	0.71		0.46	0.50	0.06
Uniform Delay, d1	20.6	16.8		16.8	16.6		35.4	15.5		35.3	13.7	10.8
Progression Factor	1.00	1.00		1.00	1.00		1.00	1.00		1.00	1.00	1.00
Incremental Delay, d2	2.3	0.0		0.0	0.0		21.1	2.2		14.3	0.7	0.1
Delay (s)	22.9	16.8		16.8	16.7		56.5	17.7		49.7	14.3	10.9
Level of Service	C	B		B	B		E	B		D	B	B
Approach Delay (s)		22.1			16.8			18.1			14.2	
Approach LOS		C			B			B			B	

Intersection Summary		
HCM 2000 Control Delay	17.2	HCM 2000 Level of Service
HCM 2000 Volume to Capacity ratio	0.67	B
Actuated Cycle Length (s)	72.2	Sum of lost time (s)
Intersection Capacity Utilization	56.3%	14.5
Analysis Period (min)	15	ICU Level of Service
c Critical Lane Group		B



Intersection						
Int Delay, s/veh	18.4					
Movement	WBL	WBR	NBT	NBR	SBL	SBT
Lane Configurations	↙	↗	↕		↙	↕
Traffic Vol, veh/h	75	145	1055	60	75	655
Future Vol, veh/h	75	145	1055	60	75	655
Conflicting Peds, #/hr	0	0	0	0	0	0
Sign Control	Stop	Stop	Free	Free	Free	Free
RT Channelized	-	None	-	None	-	None
Storage Length	0	0	-	-	340	-
Veh in Median Storage, #	0	-	0	-	-	0
Grade, %	0	-	0	-	-	0
Peak Hour Factor	86	86	86	86	86	86
Heavy Vehicles, %	7	0	7	2	5	6
Mvmt Flow	87	169	1227	70	87	762

Major/Minor	Minor1	Major1	Major2		
Conflicting Flow All	1817	649	0	0	1297
Stage 1	1262	-	-	-	-
Stage 2	555	-	-	-	-
Critical Hdwy	6.94	6.9	-	-	4.2
Critical Hdwy Stg 1	5.94	-	-	-	-
Critical Hdwy Stg 2	5.94	-	-	-	-
Follow-up Hdwy	3.57	3.3	-	-	2.25
Pot Cap-1 Maneuver	~ 66	417	-	-	514
Stage 1	220	-	-	-	-
Stage 2	525	-	-	-	-
Platoon blocked, %					
Mov Cap-1 Maneuver	~ 55	417	-	-	514
Mov Cap-2 Maneuver	~ 55	-	-	-	-
Stage 1	220	-	-	-	-
Stage 2	436	-	-	-	-

Approach	WB	NB	SB
HCM Control Delay, s	168	0	1.4
HCM LOS	F		

Minor Lane/Major Mvmt	NBT	NBRWBLn1	WBLn2	SBL	SBT
Capacity (veh/h)	-	-	55	417	514
HCM Lane V/C Ratio	-	-	1.586	0.404	0.17
HCM Control Delay (s)	-	-	\$ 455.3	19.4	13.4
HCM Lane LOS	-	-	F	C	B
HCM 95th %tile Q(veh)	-	-	8.1	1.9	0.6

Notes  
 ~: Volume exceeds capacity    \$: Delay exceeds 300s    +: Computation Not Defined    \*: All major volume in platoon

# HCM Signalized Intersection Capacity Analysis

## 4: Sequoia Pkwy & Hazeldell Way

04/09/2020



Movement	EBL	EBT	EBR	WBL	WBT	WBR	NBL	NBT	NBR	SBL	SBT	SBR
Lane Configurations	↖	↑	↗	↖	↗		↖	↗		↖	↗	
Traffic Volume (vph)	90	10	30	5	20	95	20	120	10	150	110	20
Future Volume (vph)	90	10	30	5	20	95	20	120	10	150	110	20
Ideal Flow (vphpl)	1750	1750	1750	1750	1750	1750	1750	1750	1750	1750	1750	1750
Total Lost time (s)	4.0	4.0	4.0	4.0	4.0		4.0	4.0		4.0	4.0	
Lane Util. Factor	1.00	1.00	1.00	1.00	1.00		1.00	1.00		1.00	1.00	
Frpb, ped/bikes	1.00	1.00	1.00	1.00	0.98		1.00	1.00		1.00	1.00	
Flpb, ped/bikes	1.00	1.00	1.00	1.00	1.00		1.00	1.00		1.00	1.00	
Frt	1.00	1.00	0.85	1.00	0.88		1.00	0.99		1.00	0.98	
Flt Protected	0.95	1.00	1.00	0.95	1.00		0.95	1.00		0.95	1.00	
Satd. Flow (prot)	1614	1750	1488	1662	1432		1511	1572		1662	1492	
Flt Permitted	0.95	1.00	1.00	0.95	1.00		0.95	1.00		0.95	1.00	
Satd. Flow (perm)	1614	1750	1488	1662	1432		1511	1572		1662	1492	
Peak-hour factor, PHF	0.89	0.89	0.89	0.89	0.89	0.89	0.89	0.89	0.89	0.89	0.89	0.89
Adj. Flow (vph)	101	11	34	6	22	107	22	135	11	169	124	22
RTOR Reduction (vph)	0	0	27	0	96	0	0	3	0	0	5	0
Lane Group Flow (vph)	101	11	7	6	33	0	22	143	0	169	141	0
Confl. Peds. (#/hr)	3					3						
Heavy Vehicles (%)	3%	0%	0%	0%	0%	6%	10%	10%	11%	0%	16%	7%
Turn Type	Prot	NA	Perm	Prot	NA		Prot	NA		Prot	NA	
Protected Phases	7	4		3	8		5	2		1	6	
Permitted Phases			4									
Actuated Green, G (s)	6.9	11.4	11.4	1.0	5.5		1.2	15.9		8.6	23.3	
Effective Green, g (s)	6.9	11.4	11.4	1.0	5.5		1.2	15.9		8.6	23.3	
Actuated g/C Ratio	0.13	0.22	0.22	0.02	0.10		0.02	0.30		0.16	0.44	
Clearance Time (s)	4.0	4.0	4.0	4.0	4.0		4.0	4.0		4.0	4.0	
Vehicle Extension (s)	3.0	3.0	3.0	3.0	3.0		3.0	3.0		3.0	3.0	
Lane Grp Cap (vph)	210	377	320	31	148		34	472		270	657	
v/s Ratio Prot	c0.06	0.01		0.00	c0.02		0.01	c0.09		c0.10	0.09	
v/s Ratio Perm			0.00									
v/c Ratio	0.48	0.03	0.02	0.19	0.22		0.65	0.30		0.63	0.21	
Uniform Delay, d1	21.3	16.4	16.4	25.6	21.7		25.6	14.2		20.7	9.1	
Progression Factor	1.00	1.00	1.00	1.00	1.00		1.00	1.00		1.00	1.00	
Incremental Delay, d2	1.7	0.0	0.0	3.0	0.8		35.3	0.4		4.5	0.2	
Delay (s)	23.1	16.4	16.4	28.6	22.5		60.9	14.6		25.1	9.3	
Level of Service	C	B	B	C	C		E	B		C	A	
Approach Delay (s)		21.0			22.8			20.7			17.8	
Approach LOS		C			C			C			B	

Intersection Summary			
HCM 2000 Control Delay	19.9	HCM 2000 Level of Service	B
HCM 2000 Volume to Capacity ratio	0.40		
Actuated Cycle Length (s)	52.9	Sum of lost time (s)	16.0
Intersection Capacity Utilization	38.6%	ICU Level of Service	A
Analysis Period (min)	15		

c Critical Lane Group

Intersection						
Int Delay, s/veh	2.6					
Movement	WBL	WBR	NBT	NBR	SBL	SBT
Lane Configurations	W	W	T	T	T	T
Traffic Vol, veh/h	25	25	100	30	25	70
Future Vol, veh/h	25	25	100	30	25	70
Conflicting Peds, #/hr	1	0	0	0	0	0
Sign Control	Stop	Stop	Free	Free	Free	Free
RT Channelized	-	None	-	None	-	None
Storage Length	0	-	-	-	-	-
Veh in Median Storage, #	0	-	0	-	-	0
Grade, %	0	-	0	-	-	0
Peak Hour Factor	88	88	92	92	92	92
Heavy Vehicles, %	20	20	6	0	30	3
Mvmt Flow	28	28	109	33	27	76

Major/Minor	Minor1	Major1	Major2			
Conflicting Flow All	256	125	0	0	141	0
Stage 1	125	-	-	-	-	-
Stage 2	131	-	-	-	-	-
Critical Hdwy	6.6	6.4	-	-	4.4	-
Critical Hdwy Stg 1	5.6	-	-	-	-	-
Critical Hdwy Stg 2	5.6	-	-	-	-	-
Follow-up Hdwy	3.68	3.48	-	-	2.47	-
Pot Cap-1 Maneuver	695	879	-	-	1287	-
Stage 1	858	-	-	-	-	-
Stage 2	853	-	-	-	-	-
Platoon blocked, %			-	-	-	-
Mov Cap-1 Maneuver	679	879	-	-	1287	-
Mov Cap-2 Maneuver	695	-	-	-	-	-
Stage 1	858	-	-	-	-	-
Stage 2	833	-	-	-	-	-

Approach	WB	NB	SB
HCM Control Delay, s	10	0	2.1
HCM LOS	B		

Minor Lane/Major Mvmt	NBT	NBRWBLn1	SBL	SBT
Capacity (veh/h)	-	-	776	1287
HCM Lane V/C Ratio	-	-	0.073	0.021
HCM Control Delay (s)	-	-	10	7.9
HCM Lane LOS	-	-	B	A
HCM 95th %tile Q(veh)	-	-	0.2	0.1

Intersection						
Int Delay, s/veh	2.6					
Movement	EBT	EBR	WBL	WBT	NBL	NBR
Lane Configurations						
Traffic Vol, veh/h	20	0	20	65	10	10
Future Vol, veh/h	20	0	20	65	10	10
Conflicting Peds, #/hr	0	0	0	0	0	0
Sign Control	Free	Free	Free	Free	Stop	Stop
RT Channelized	-	None	-	None	-	None
Storage Length	-	-	-	-	0	-
Veh in Median Storage, #	0	-	-	0	0	-
Grade, %	0	-	-	0	0	-
Peak Hour Factor	87	87	87	87	87	87
Heavy Vehicles, %	11	100	0	2	0	33
Mvmt Flow	23	0	23	75	11	11

Major/Minor	Major1	Major2	Minor1		
Conflicting Flow All	0	0	23	0	144 23
Stage 1	-	-	-	-	23 -
Stage 2	-	-	-	-	121 -
Critical Hdwy	-	-	4.1	-	6.4 6.53
Critical Hdwy Stg 1	-	-	-	-	5.4 -
Critical Hdwy Stg 2	-	-	-	-	5.4 -
Follow-up Hdwy	-	-	2.2	-	3.5 3.597
Pot Cap-1 Maneuver	-	-	1605	-	853 971
Stage 1	-	-	-	-	1005 -
Stage 2	-	-	-	-	909 -
Platoon blocked, %	-	-	-	-	-
Mov Cap-1 Maneuver	-	-	1605	-	840 971
Mov Cap-2 Maneuver	-	-	-	-	840 -
Stage 1	-	-	-	-	1005 -
Stage 2	-	-	-	-	895 -

Approach	EB	WB	NB
HCM Control Delay, s	0	1.7	9.1
HCM LOS			A

Minor Lane/Major Mvmt	NBLn1	EBT	EBR	WBL	WBT
Capacity (veh/h)	901	-	-	1605	-
HCM Lane V/C Ratio	0.026	-	-	0.014	-
HCM Control Delay (s)	9.1	-	-	7.3	0
HCM Lane LOS	A	-	-	A	A
HCM 95th %tile Q(veh)	0.1	-	-	0	-

Intersection						
Int Delay, s/veh	5.5					
Movement	EBT	EBR	WBL	WBT	NBL	NBR
Lane Configurations						
Traffic Vol, veh/h	20	10	45	70	15	110
Future Vol, veh/h	20	10	45	70	15	110
Conflicting Peds, #/hr	0	0	0	0	0	0
Sign Control	Free	Free	Free	Free	Stop	Stop
RT Channelized	-	None	-	None	-	None
Storage Length	-	-	-	-	0	-
Veh in Median Storage, #	0	-	-	0	0	-
Grade, %	0	-	-	0	0	-
Peak Hour Factor	82	82	82	82	82	82
Heavy Vehicles, %	18	0	0	4	0	0
Mvmt Flow	24	12	55	85	18	134

Major/Minor	Major1	Major2	Minor1		
Conflicting Flow All	0	0	36	0	225 30
Stage 1	-	-	-	-	30 -
Stage 2	-	-	-	-	195 -
Critical Hdwy	-	-	4.1	-	6.4 6.2
Critical Hdwy Stg 1	-	-	-	-	5.4 -
Critical Hdwy Stg 2	-	-	-	-	5.4 -
Follow-up Hdwy	-	-	2.2	-	3.5 3.3
Pot Cap-1 Maneuver	-	-	1588	-	768 1050
Stage 1	-	-	-	-	998 -
Stage 2	-	-	-	-	843 -
Platoon blocked, %	-	-	-	-	-
Mov Cap-1 Maneuver	-	-	1588	-	740 1050
Mov Cap-2 Maneuver	-	-	-	-	740 -
Stage 1	-	-	-	-	998 -
Stage 2	-	-	-	-	813 -

Approach	EB	WB	NB
HCM Control Delay, s	0	2.9	9.2
HCM LOS			A

Minor Lane/Major Mvmt	NBLn1	EBT	EBR	WBL	WBT
Capacity (veh/h)	1000	-	-	1588	-
HCM Lane V/C Ratio	0.152	-	-	0.035	-
HCM Control Delay (s)	9.2	-	-	7.3	0
HCM Lane LOS	A	-	-	A	A
HCM 95th %tile Q(veh)	0.5	-	-	0.1	-



Intersection						
Int Delay, s/veh	2.1					
Movement	WBL	WBR	NBT	NBR	SBL	SBT
Lane Configurations	Y		T			T
Traffic Vol, veh/h	30	25	115	15	5	85
Future Vol, veh/h	30	25	115	15	5	85
Conflicting Peds, #/hr	0	0	0	0	0	0
Sign Control	Stop	Stop	Free	Free	Free	Free
RT Channelized	-	None	-	None	-	None
Storage Length	0	-	-	-	-	-
Veh in Median Storage, #	0	-	0	-	-	0
Grade, %	0	-	0	-	-	0
Peak Hour Factor	89	89	89	89	89	89
Heavy Vehicles, %	10	0	3	17	0	4
Mvmt Flow	34	28	129	17	6	96

Major/Minor	Minor1	Major1	Major2			
Conflicting Flow All	246	138	0	0	146	0
Stage 1	138	-	-	-	-	-
Stage 2	108	-	-	-	-	-
Critical Hdwy	6.5	6.2	-	-	4.1	-
Critical Hdwy Stg 1	5.5	-	-	-	-	-
Critical Hdwy Stg 2	5.5	-	-	-	-	-
Follow-up Hdwy	3.59	3.3	-	-	2.2	-
Pot Cap-1 Maneuver	725	916	-	-	1448	-
Stage 1	869	-	-	-	-	-
Stage 2	897	-	-	-	-	-
Platoon blocked, %			-	-	-	-
Mov Cap-1 Maneuver	722	916	-	-	1448	-
Mov Cap-2 Maneuver	722	-	-	-	-	-
Stage 1	869	-	-	-	-	-
Stage 2	893	-	-	-	-	-

Approach	WB	NB	SB
HCM Control Delay, s	9.9	0	0.4
HCM LOS	A		

Minor Lane/Major Mvmt	NBT	NBRWBLn1	SBL	SBT
Capacity (veh/h)	-	-	799	1448
HCM Lane V/C Ratio	-	-	0.077	0.004
HCM Control Delay (s)	-	-	9.9	7.5
HCM Lane LOS	-	-	A	A
HCM 95th %tile Q(veh)	-	-	0.3	0

HCM Signalized Intersection Capacity Analysis  
 1: OR 99E & Redwood St/Sequoia Pkwy

03/13/2020



Movement	EBL	EBT	EBR	WBL	WBT	WBR	NBL	NBT	NBR	SBL	SBT	SBR
Lane Configurations	↖	↗		↖↗	↑	↖	↖	↑↑	↖	↖	↖↗	
Traffic Volume (vph)	5	75	40	400	70	135	60	765	155	140	1015	20
Future Volume (vph)	5	75	40	400	70	135	60	765	155	140	1015	20
Ideal Flow (vphpl)	1750	1750	1750	1750	1750	1750	1750	1750	1750	1750	1750	1750
Total Lost time (s)	4.0	4.0		4.0	4.0	4.0	4.0	5.4	5.4	4.0	5.4	
Lane Util. Factor	1.00	1.00		0.97	1.00	1.00	1.00	0.95	1.00	1.00	0.95	
Frt	1.00	0.95		1.00	1.00	0.85	1.00	1.00	0.85	1.00	1.00	
Flt Protected	0.95	1.00		0.95	1.00	1.00	0.95	1.00	1.00	0.95	1.00	
Satd. Flow (prot)	1662	1620		3193	1750	1430	1599	3167	1430	1646	3190	
Flt Permitted	0.95	1.00		0.95	1.00	1.00	0.95	1.00	1.00	0.95	1.00	
Satd. Flow (perm)	1662	1620		3193	1750	1430	1599	3167	1430	1646	3190	
Peak-hour factor, PHF	0.91	0.91	0.91	0.91	0.91	0.91	0.91	0.91	0.91	0.91	0.91	0.91
Adj. Flow (vph)	5	82	44	440	77	148	66	841	170	154	1115	22
RTOR Reduction (vph)	0	19	0	0	0	123	0	0	100	0	1	0
Lane Group Flow (vph)	5	107	0	440	77	25	66	841	70	154	1136	0
Heavy Vehicles (%)	0%	1%	5%	1%	0%	4%	4%	5%	4%	1%	4%	0%
Turn Type	Split	NA		Split	NA	Perm	Prot	NA	Perm	Prot	NA	
Protected Phases	8	8		4	4		1	6		5	2	
Permitted Phases						4			6			
Actuated Green, G (s)	10.7	10.7		15.4	15.4	15.4	6.9	37.8	37.8	11.0	41.9	
Effective Green, g (s)	10.7	10.7		15.4	15.4	15.4	6.9	37.8	37.8	11.0	41.9	
Actuated g/C Ratio	0.12	0.12		0.17	0.17	0.17	0.07	0.41	0.41	0.12	0.45	
Clearance Time (s)	4.0	4.0		4.0	4.0	4.0	4.0	5.4	5.4	4.0	5.4	
Vehicle Extension (s)	2.3	2.3		2.3	2.3	2.3	2.3	5.5	5.5	2.3	5.5	
Lane Grp Cap (vph)	192	187		532	291	238	119	1296	585	196	1448	
v/s Ratio Prot	0.00	c0.07		c0.14	0.04		0.04	0.27		c0.09	c0.36	
v/s Ratio Perm						0.02			0.05			
v/c Ratio	0.03	0.57		0.83	0.26	0.10	0.55	0.65	0.12	0.79	0.78	
Uniform Delay, d1	36.2	38.6		37.2	33.5	32.6	41.2	21.9	16.9	39.5	21.4	
Progression Factor	1.00	1.00		1.00	1.00	1.00	1.00	1.00	1.00	1.00	1.00	
Incremental Delay, d2	0.0	2.9		9.9	0.3	0.1	3.9	1.7	0.2	17.6	3.4	
Delay (s)	36.2	41.5		47.0	33.8	32.7	45.1	23.6	17.1	57.1	24.8	
Level of Service	D	D		D	C	C	D	C	B	E	C	
Approach Delay (s)		41.3			42.3			23.9			28.7	
Approach LOS		D			D			C			C	

Intersection Summary		
HCM 2000 Control Delay	30.4	HCM 2000 Level of Service C
HCM 2000 Volume to Capacity ratio	0.79	
Actuated Cycle Length (s)	92.3	Sum of lost time (s) 17.4
Intersection Capacity Utilization	65.0%	ICU Level of Service C
Analysis Period (min)	15	
c Critical Lane Group		

HCM Signalized Intersection Capacity Analysis  
 2: OR 99 E & NE Territorial Rd/SE Territorial Rd

03/13/2020



Movement	EBL	EBT	EBR	WBL	WBT	WBR	NBL	NBT	NBR	SBL	SBT	SBR
Lane Configurations												
Traffic Volume (vph)	185	20	25	15	40	5	30	985	15	5	1070	260
Future Volume (vph)	185	20	25	15	40	5	30	985	15	5	1070	260
Ideal Flow (vphpl)	1750	1750	1750	1750	1750	1750	1750	1750	1750	1750	1750	1750
Total Lost time (s)	4.5	4.5		4.5	4.5		4.0	6.0		4.0	6.0	6.0
Lane Util. Factor	1.00	1.00		1.00	1.00		1.00	0.95		1.00	0.95	1.00
Frt	1.00	0.92		1.00	0.98		1.00	1.00		1.00	1.00	0.85
Flt Protected	0.95	1.00		0.95	1.00		0.95	1.00		0.95	1.00	1.00
Satd. Flow (prot)	1646	1562		1554	1722		1662	3185		1330	3167	1473
Flt Permitted	0.73	1.00		0.73	1.00		0.95	1.00		0.95	1.00	1.00
Satd. Flow (perm)	1259	1562		1188	1722		1662	3185		1330	3167	1473
Peak-hour factor, PHF	0.96	0.96	0.96	0.96	0.96	0.96	0.96	0.96	0.96	0.96	0.96	0.96
Adj. Flow (vph)	193	21	26	16	42	5	31	1026	16	5	1115	271
RTOR Reduction (vph)	0	20	0	0	4	0	0	1	0	0	0	123
Lane Group Flow (vph)	193	27	0	16	43	0	31	1041	0	5	1115	148
Heavy Vehicles (%)	1%	0%	5%	7%	0%	0%	0%	4%	15%	25%	5%	1%
Turn Type	Perm	NA		Perm	NA		Prot	NA		Prot	NA	Perm
Protected Phases		8			4		1	6		5	2	
Permitted Phases	8			4								2
Actuated Green, G (s)	19.1	19.1		19.1	19.1		3.8	47.6		0.9	44.7	44.7
Effective Green, g (s)	19.1	19.1		19.1	19.1		3.8	47.6		0.9	44.7	44.7
Actuated g/C Ratio	0.23	0.23		0.23	0.23		0.05	0.58		0.01	0.54	0.54
Clearance Time (s)	4.5	4.5		4.5	4.5		4.0	6.0		4.0	6.0	6.0
Vehicle Extension (s)	2.5	2.5		2.5	2.5		2.3	5.4		2.3	5.4	5.4
Lane Grp Cap (vph)	292	363		276	400		76	1846		14	1724	801
v/s Ratio Prot		0.02			0.03		c0.02	c0.33		0.00	c0.35	
v/s Ratio Perm	c0.15			0.01								0.10
v/c Ratio	0.66	0.07		0.06	0.11		0.41	0.56		0.36	0.65	0.18
Uniform Delay, d1	28.6	24.6		24.5	24.8		38.1	10.8		40.3	13.1	9.5
Progression Factor	1.00	1.00		1.00	1.00		1.00	1.00		1.00	1.00	1.00
Incremental Delay, d2	5.0	0.1		0.1	0.1		2.1	0.7		8.9	1.2	0.3
Delay (s)	33.5	24.7		24.6	24.9		40.1	11.5		49.2	14.4	9.7
Level of Service	C	C		C	C		D	B		D	B	A
Approach Delay (s)		31.8			24.8			12.3			13.6	
Approach LOS		C			C			B			B	

Intersection Summary

HCM 2000 Control Delay	14.9	HCM 2000 Level of Service	B
HCM 2000 Volume to Capacity ratio	0.63		
Actuated Cycle Length (s)	82.1	Sum of lost time (s)	14.5
Intersection Capacity Utilization	58.7%	ICU Level of Service	B
Analysis Period (min)	15		
c Critical Lane Group			

Intersection						
Int Delay, s/veh	10.9					
Movement	WBL	WBR	NBT	NBR	SBL	SBT
Lane Configurations	↵	↵	↕↕		↵	↕↕
Traffic Vol, veh/h	50	85	1020	100	145	1290
Future Vol, veh/h	50	85	1020	100	145	1290
Conflicting Peds, #/hr	0	0	0	0	0	0
Sign Control	Stop	Stop	Free	Free	Free	Free
RT Channelized	-	None	-	None	-	None
Storage Length	0	0	-	-	340	-
Veh in Median Storage, #	0	-	0	-	-	0
Grade, %	0	-	0	-	-	0
Peak Hour Factor	96	96	96	96	96	96
Heavy Vehicles, %	2	1	2	1	0	3
Mvmt Flow	52	89	1063	104	151	1344

Major/Minor	Minor1	Major1	Major2			
Conflicting Flow All	2089	584	0	0	1167	0
Stage 1	1115	-	-	-	-	-
Stage 2	974	-	-	-	-	-
Critical Hdwy	6.84	6.92	-	-	4.1	-
Critical Hdwy Stg 1	5.84	-	-	-	-	-
Critical Hdwy Stg 2	5.84	-	-	-	-	-
Follow-up Hdwy	3.52	3.31	-	-	2.2	-
Pot Cap-1 Maneuver	~ 45	457	-	-	606	-
Stage 1	275	-	-	-	-	-
Stage 2	327	-	-	-	-	-
Platoon blocked, %						
Mov Cap-1 Maneuver	~ 34	457	-	-	606	-
Mov Cap-2 Maneuver	~ 34	-	-	-	-	-
Stage 1	275	-	-	-	-	-
Stage 2	246	-	-	-	-	-

Approach	WB	NB	SB
HCM Control Delay, s	204.1	0	1.3
HCM LOS	F		

Minor Lane/Major Mvmt	NBT	NBRWBLn1	WBLn2	SBL	SBT
Capacity (veh/h)	-	-	34	457	606
HCM Lane V/C Ratio	-	-	1.532	0.194	0.249
HCM Control Delay (s)	-	-	\$ 526	14.8	12.9
HCM Lane LOS	-	-	F	B	B
HCM 95th %tile Q(veh)	-	-	5.7	0.7	1

Notes  
 ~: Volume exceeds capacity    \$: Delay exceeds 300s    +: Computation Not Defined    \*: All major volume in platoon

# HCM Signalized Intersection Capacity Analysis

## 4: Sequoia Pkwy & Hazeldell Way

04/09/2020



Movement	EBL	EBT	EBR	WBL	WBT	WBR	NBL	NBT	NBR	SBL	SBT	SBR
Lane Configurations	↖	↑	↗	↖	↗		↖	↗		↖	↗	
Traffic Volume (vph)	275	25	15	15	35	175	65	150	5	125	130	55
Future Volume (vph)	275	25	15	15	35	175	65	150	5	125	130	55
Ideal Flow (vphp)	1750	1750	1750	1750	1750	1750	1750	1750	1750	1750	1750	1750
Total Lost time (s)	4.0	4.0	4.0	4.0	4.0		4.0	4.0		4.0	4.0	
Lane Util. Factor	1.00	1.00	1.00	1.00	1.00		1.00	1.00		1.00	1.00	
Frt	1.00	1.00	0.85	1.00	0.88		1.00	1.00		1.00	0.96	
Flt Protected	0.95	1.00	1.00	0.95	1.00		0.95	1.00		0.95	1.00	
Satd. Flow (prot)	1646	1750	1488	1662	1506		1662	1709		1614	1649	
Flt Permitted	0.95	1.00	1.00	0.95	1.00		0.95	1.00		0.95	1.00	
Satd. Flow (perm)	1646	1750	1488	1662	1506		1662	1709		1614	1649	
Peak-hour factor, PHF	0.95	0.95	0.95	0.95	0.95	0.95	0.95	0.95	0.95	0.95	0.95	0.95
Adj. Flow (vph)	289	26	16	16	37	184	68	158	5	132	137	58
RTOR Reduction (vph)	0	0	10	0	160	0	0	2	0	0	15	0
Lane Group Flow (vph)	289	26	6	16	61	0	68	161	0	132	180	0
Heavy Vehicles (%)	1%	0%	0%	0%	0%	2%	0%	2%	0%	3%	2%	0%
Turn Type	Prot	NA	Perm	Prot	NA		Prot	NA		Prot	NA	
Protected Phases	7	4		3	8		5	2		1	6	
Permitted Phases			4									
Actuated Green, G (s)	16.5	23.6	23.6	1.2	8.3		4.3	14.3		8.3	18.3	
Effective Green, g (s)	16.5	23.6	23.6	1.2	8.3		4.3	14.3		8.3	18.3	
Actuated g/C Ratio	0.26	0.37	0.37	0.02	0.13		0.07	0.23		0.13	0.29	
Clearance Time (s)	4.0	4.0	4.0	4.0	4.0		4.0	4.0		4.0	4.0	
Vehicle Extension (s)	3.0	3.0	3.0	3.0	3.0		3.0	3.0		3.0	3.0	
Lane Grp Cap (vph)	428	651	553	31	197		112	385		211	475	
v/s Ratio Prot	c0.18	0.01		0.01	c0.04		0.04	0.09		c0.08	c0.11	
v/s Ratio Perm			0.00									
v/c Ratio	0.68	0.04	0.01	0.52	0.31		0.61	0.42		0.63	0.38	
Uniform Delay, d1	21.0	12.7	12.5	30.8	25.0		28.7	21.0		26.1	18.0	
Progression Factor	1.00	1.00	1.00	1.00	1.00		1.00	1.00		1.00	1.00	
Incremental Delay, d2	4.2	0.0	0.0	13.7	0.9		9.0	0.7		5.7	0.5	
Delay (s)	25.2	12.7	12.6	44.6	25.9		37.7	21.7		31.8	18.5	
Level of Service	C	B	B	D	C		D	C		C	B	
Approach Delay (s)		23.6			27.1			26.4			23.9	
Approach LOS		C			C			C			C	

Intersection Summary			
HCM 2000 Control Delay	25.0	HCM 2000 Level of Service	C
HCM 2000 Volume to Capacity ratio	0.51		
Actuated Cycle Length (s)	63.4	Sum of lost time (s)	16.0
Intersection Capacity Utilization	60.0%	ICU Level of Service	B
Analysis Period (min)	15		
c Critical Lane Group			



Intersection						
Int Delay, s/veh	1.4					
Movement	WBL	WBR	NBT	NBR	SBL	SBT
Lane Configurations	Y		T		T	T
Traffic Vol, veh/h	35	15	120	15	10	270
Future Vol, veh/h	35	15	120	15	10	270
Conflicting Peds, #/hr	0	0	0	0	0	0
Sign Control	Stop	Stop	Free	Free	Free	Free
RT Channelized	-	None	-	None	-	None
Storage Length	0	-	-	-	500	-
Veh in Median Storage, #	0	-	0	-	-	0
Grade, %	0	-	0	-	-	0
Peak Hour Factor	84	84	84	84	84	84
Heavy Vehicles, %	0	0	1	17	0	1
Mvmt Flow	42	18	143	18	12	321

Major/Minor	Minor1	Major1	Major2		
Conflicting Flow All	497	152	0	0	161
Stage 1	152	-	-	-	-
Stage 2	345	-	-	-	-
Critical Hdwy	6.4	6.2	-	-	4.1
Critical Hdwy Stg 1	5.4	-	-	-	-
Critical Hdwy Stg 2	5.4	-	-	-	-
Follow-up Hdwy	3.5	3.3	-	-	2.2
Pot Cap-1 Maneuver	536	900	-	-	1430
Stage 1	881	-	-	-	-
Stage 2	722	-	-	-	-
Platoon blocked, %			-	-	-
Mov Cap-1 Maneuver	532	900	-	-	1430
Mov Cap-2 Maneuver	596	-	-	-	-
Stage 1	881	-	-	-	-
Stage 2	716	-	-	-	-

Approach	WB	NB	SB
HCM Control Delay, s	11	0	0.3
HCM LOS	B		

Minor Lane/Major Mvmt	NBT	NBRWBLn1	SBL	SBT
Capacity (veh/h)	-	-	663	1430
HCM Lane V/C Ratio	-	-	0.09	0.008
HCM Control Delay (s)	-	-	11	7.5
HCM Lane LOS	-	-	B	A
HCM 95th %tile Q(veh)	-	-	0.3	0

Intersection						
Int Delay, s/veh	2.1					
Movement	EBT	EBR	WBL	WBT	NBL	NBR
Lane Configurations						
Traffic Vol, veh/h	85	5	10	55	5	30
Future Vol, veh/h	85	5	10	55	5	30
Conflicting Peds, #/hr	0	0	0	0	0	0
Sign Control	Free	Free	Free	Free	Stop	Stop
RT Channelized	-	None	-	None	-	None
Storage Length	-	-	-	-	0	-
Veh in Median Storage, #	0	-	-	0	0	-
Grade, %	0	-	-	0	0	-
Peak Hour Factor	86	86	86	86	86	86
Heavy Vehicles, %	3	0	14	0	0	8
Mvmt Flow	99	6	12	64	6	35

Major/Minor	Major1	Major2	Minor1		
Conflicting Flow All	0	0	105	0	190 102
Stage 1	-	-	-	-	102 -
Stage 2	-	-	-	-	88 -
Critical Hdwy	-	-	4.24	-	6.4 6.28
Critical Hdwy Stg 1	-	-	-	-	5.4 -
Critical Hdwy Stg 2	-	-	-	-	5.4 -
Follow-up Hdwy	-	-	2.326	-	3.5 3.372
Pot Cap-1 Maneuver	-	-	1415	-	804 937
Stage 1	-	-	-	-	927 -
Stage 2	-	-	-	-	940 -
Platoon blocked, %	-	-	-	-	-
Mov Cap-1 Maneuver	-	-	1415	-	797 937
Mov Cap-2 Maneuver	-	-	-	-	797 -
Stage 1	-	-	-	-	927 -
Stage 2	-	-	-	-	932 -

Approach	EB	WB	NB
HCM Control Delay, s	0	1.2	9.1
HCM LOS			A

Minor Lane/Major Mvmt	NBLn1	EBT	EBR	WBL	WBT
Capacity (veh/h)	914	-	-	1415	-
HCM Lane V/C Ratio	0.045	-	-	0.008	-
HCM Control Delay (s)	9.1	-	-	7.6	0
HCM Lane LOS	A	-	-	A	A
HCM 95th %tile Q(veh)	0.1	-	-	0	-

Intersection						
Int Delay, s/veh	4.5					
Movement	EBT	EBR	WBL	WBT	NBL	NBR
Lane Configurations						
Traffic Vol, veh/h	100	15	125	55	10	55
Future Vol, veh/h	100	15	125	55	10	55
Conflicting Peds, #/hr	0	0	0	0	0	0
Sign Control	Free	Free	Free	Free	Stop	Stop
RT Channelized	-	None	-	None	-	None
Storage Length	-	-	-	-	0	-
Veh in Median Storage, #	0	-	-	0	0	-
Grade, %	0	-	-	0	0	-
Peak Hour Factor	86	86	86	86	86	86
Heavy Vehicles, %	3	20	0	3	0	0
Mvmt Flow	116	17	145	64	12	64

Major/Minor	Major1	Major2	Minor1		
Conflicting Flow All	0	0	133	0	479 125
Stage 1	-	-	-	-	125 -
Stage 2	-	-	-	-	354 -
Critical Hdwy	-	-	4.1	-	6.4 6.2
Critical Hdwy Stg 1	-	-	-	-	5.4 -
Critical Hdwy Stg 2	-	-	-	-	5.4 -
Follow-up Hdwy	-	-	2.2	-	3.5 3.3
Pot Cap-1 Maneuver	-	-	1464	-	549 931
Stage 1	-	-	-	-	906 -
Stage 2	-	-	-	-	715 -
Platoon blocked, %	-	-	-	-	-
Mov Cap-1 Maneuver	-	-	1464	-	492 931
Mov Cap-2 Maneuver	-	-	-	-	492 -
Stage 1	-	-	-	-	906 -
Stage 2	-	-	-	-	641 -

Approach	EB	WB	NB
HCM Control Delay, s	0	5.4	9.8
HCM LOS			A

Minor Lane/Major Mvmt	NBLn1	EBT	EBR	WBL	WBT
Capacity (veh/h)	819	-	-	1464	-
HCM Lane V/C Ratio	0.092	-	-	0.099	-
HCM Control Delay (s)	9.8	-	-	7.7	0
HCM Lane LOS	A	-	-	A	A
HCM 95th %tile Q(veh)	0.3	-	-	0.3	-

Intersection						
Int Delay, s/veh	1.1					
Movement	WBL	WBR	NBT	NBR	SBL	SBT
Lane Configurations	W	W	T	T	T	T
Traffic Vol, veh/h	15	15	115	40	15	165
Future Vol, veh/h	15	15	115	40	15	165
Conflicting Peds, #/hr	0	0	0	0	0	0
Sign Control	Stop	Stop	Free	Free	Free	Free
RT Channelized	-	None	-	None	-	None
Storage Length	0	-	-	-	-	-
Veh in Median Storage, #	0	-	0	-	-	0
Grade, %	0	-	0	-	-	0
Peak Hour Factor	89	89	89	89	89	89
Heavy Vehicles, %	13	0	1	6	7	5
Mvmt Flow	17	17	129	45	17	185



























Major/Minor	Minor1	Major1	Major2		
Conflicting Flow All	371	152	0	0	174
Stage 1	152	-	-	-	-
Stage 2	219	-	-	-	-
Critical Hdwy	6.53	6.2	-	-	4.17
Critical Hdwy Stg 1	5.53	-	-	-	-
Critical Hdwy Stg 2	5.53	-	-	-	-
Follow-up Hdwy	3.617	3.3	-	-	2.263
Pot Cap-1 Maneuver	608	900	-	-	1373
Stage 1	850	-	-	-	-
Stage 2	792	-	-	-	-
Platoon blocked, %					
Mov Cap-1 Maneuver	599	900	-	-	1373
Mov Cap-2 Maneuver	599	-	-	-	-
Stage 1	850	-	-	-	-
Stage 2	781	-	-	-	-

Approach	WB	NB	SB
HCM Control Delay, s	10.3	0	0.6
HCM LOS	B		

Minor Lane/Major Mvmt	NBT	NBRWBLn1	SBL	SBT
Capacity (veh/h)	-	-	719	1373
HCM Lane V/C Ratio	-	-	0.047	0.012
HCM Control Delay (s)	-	-	10.3	7.7
HCM Lane LOS	-	-	B	A
HCM 95th %tile Q(veh)	-	-	0.1	0

HCM Signalized Intersection Capacity Analysis  
 1: OR 99E & Redwood St/Sequoia Pkwy

03/13/2020

													
Movement	EBL	EBT	EBR	WBL	WBT	WBR	NBL	NBT	NBR	SBL	SBT	SBR	
Lane Configurations				 				 			 		
Traffic Volume (vph)	10	20	50	200	15	80	25	740	155	90	550	5	
Future Volume (vph)	10	20	50	200	15	80	25	740	155	90	550	5	
Ideal Flow (vphpl)	1750	1750	1750	1750	1750	1750	1750	1750	1750	1750	1750	1750	
Total Lost time (s)	4.0	4.0		4.0	4.0	4.0	4.0	5.4	5.4	4.0	5.4		
Lane Util. Factor	1.00	1.00		0.97	1.00	1.00	1.00	0.95	1.00	1.00	0.95		
Frpb, ped/bikes	1.00	0.99		1.00	1.00	1.00	1.00	1.00	1.00	1.00	1.00		
Flpb, ped/bikes	1.00	1.00		1.00	1.00	1.00	1.00	1.00	1.00	1.00	1.00		
Frt	1.00	0.89		1.00	1.00	0.85	1.00	1.00	0.85	1.00	1.00		
Flt Protected	0.95	1.00		0.95	1.00	1.00	0.95	1.00	1.00	0.95	1.00		
Satd. Flow (prot)	1662	1522		3072	1750	1261	1599	3079	1444	1511	3048		
Flt Permitted	0.95	1.00		0.95	1.00	1.00	0.95	1.00	1.00	0.95	1.00		
Satd. Flow (perm)	1662	1522		3072	1750	1261	1599	3079	1444	1511	3048		
Peak-hour factor, PHF	0.90	0.90	0.90	0.90	0.90	0.90	0.90	0.90	0.90	0.90	0.90	0.90	
Adj. Flow (vph)	11	22	56	222	17	89	28	822	172	100	611	6	
RTOR Reduction (vph)	0	52	0	0	0	76	0	0	95	0	0	0	
Lane Group Flow (vph)	11	26	0	222	17	13	28	822	77	100	617	0	
Confl. Peds. (#/hr)			1	1			1					1	
Heavy Vehicles (%)	0%	0%	2%	5%	0%	18%	4%	8%	3%	10%	9%	0%	
Turn Type	Split	NA		Split	NA	Perm	Prot	NA	Perm	Prot	NA		
Protected Phases	8	8		4	4		1	6		5	2		
Permitted Phases						4			6				
Actuated Green, G (s)	5.3	5.3		10.9	10.9	10.9	2.5	33.0	33.0	7.2	37.7		
Effective Green, g (s)	5.3	5.3		10.9	10.9	10.9	2.5	33.0	33.0	7.2	37.7		
Actuated g/C Ratio	0.07	0.07		0.15	0.15	0.15	0.03	0.45	0.45	0.10	0.51		
Clearance Time (s)	4.0	4.0		4.0	4.0	4.0	4.0	5.4	5.4	4.0	5.4		
Vehicle Extension (s)	2.3	2.3		2.3	2.3	2.3	2.3	5.5	5.5	2.3	5.5		
Lane Grp Cap (vph)	119	109		453	258	186	54	1376	645	147	1557		
v/s Ratio Prot	0.01	c0.02		c0.07	0.01		0.02	c0.27		c0.07	0.20		
v/s Ratio Perm						0.01			0.05				
v/c Ratio	0.09	0.24		0.49	0.07	0.07	0.52	0.60	0.12	0.68	0.40		
Uniform Delay, d1	32.0	32.3		28.9	27.1	27.1	35.1	15.4	11.9	32.2	11.1		
Progression Factor	1.00	1.00		1.00	1.00	1.00	1.00	1.00	1.00	1.00	1.00		
Incremental Delay, d2	0.2	0.7		0.5	0.1	0.1	5.1	1.2	0.2	10.7	0.4		
Delay (s)	32.2	33.0		29.4	27.1	27.2	40.1	16.6	12.1	42.9	11.5		
Level of Service	C	C		C	C	C	D	B	B	D	B		
Approach Delay (s)		32.9			28.7			16.5			15.9		
Approach LOS		C			C			B			B		
<b>Intersection Summary</b>													
HCM 2000 Control Delay			18.8		HCM 2000 Level of Service					B			
HCM 2000 Volume to Capacity ratio			0.55										
Actuated Cycle Length (s)			73.8		Sum of lost time (s)					17.4			
Intersection Capacity Utilization			51.7%		ICU Level of Service					A			
Analysis Period (min)			15										

c Critical Lane Group



HCM Signalized Intersection Capacity Analysis  
 2: OR 99 E & NE Territorial Rd/SE Territorial Rd

03/13/2020



Movement	EBL	EBT	EBR	WBL	WBT	WBR	NBL	NBT	NBR	SBL	SBT	SBR
Lane Configurations												
Traffic Volume (vph)	230	15	25	20	10	5	10	890	10	5	660	75
Future Volume (vph)	230	15	25	20	10	5	10	890	10	5	660	75
Ideal Flow (vphpl)	1750	1750	1750	1750	1750	1750	1750	1750	1750	1750	1750	1750
Total Lost time (s)	4.5	4.5		4.5	4.5		4.0	6.0		4.0	6.0	6.0
Lane Util. Factor	1.00	1.00		1.00	1.00		1.00	0.95		1.00	0.95	1.00
Frt	1.00	0.91		1.00	0.95		1.00	1.00		1.00	1.00	0.85
Flt Protected	0.95	1.00		0.95	1.00		0.95	1.00		0.95	1.00	1.00
Satd. Flow (prot)	1646	1530		1583	1395		1458	3105		950	3167	1444
Flt Permitted	0.75	1.00		0.73	1.00		0.95	1.00		0.95	1.00	1.00
Satd. Flow (perm)	1293	1530		1213	1395		1458	3105		950	3167	1444
Peak-hour factor, PHF	0.89	0.89	0.89	0.89	0.89	0.89	0.89	0.89	0.89	0.89	0.89	0.89
Adj. Flow (vph)	258	17	28	22	11	6	11	1000	11	6	742	84
RTOR Reduction (vph)	0	19	0	0	4	0	0	1	0	0	0	45
Lane Group Flow (vph)	258	26	0	22	13	0	11	1010	0	6	742	39
Heavy Vehicles (%)	1%	0%	6%	5%	11%	33%	14%	7%	0%	75%	5%	3%
Turn Type	Perm	NA		Perm	NA		Prot	NA		Prot	NA	Perm
Protected Phases		8			4		1	6		5	2	
Permitted Phases	8			4								2
Actuated Green, G (s)	23.4	23.4		23.4	23.4		1.0	33.3		1.0	33.3	33.3
Effective Green, g (s)	23.4	23.4		23.4	23.4		1.0	33.3		1.0	33.3	33.3
Actuated g/C Ratio	0.32	0.32		0.32	0.32		0.01	0.46		0.01	0.46	0.46
Clearance Time (s)	4.5	4.5		4.5	4.5		4.0	6.0		4.0	6.0	6.0
Vehicle Extension (s)	2.5	2.5		2.5	2.5		2.3	5.4		2.3	5.4	5.4
Lane Grp Cap (vph)	419	495		393	452		20	1432		13	1460	666
v/s Ratio Prot		0.02			0.01		c0.01	c0.33		0.01	0.23	
v/s Ratio Perm	c0.20			0.02								0.03
v/c Ratio	0.62	0.05		0.06	0.03		0.55	0.71		0.46	0.51	0.06
Uniform Delay, d1	20.6	16.8		16.8	16.6		35.4	15.5		35.3	13.7	10.8
Progression Factor	1.00	1.00		1.00	1.00		1.00	1.00		1.00	1.00	1.00
Incremental Delay, d2	2.3	0.0		0.0	0.0		21.1	2.2		14.3	0.7	0.1
Delay (s)	22.9	16.8		16.8	16.7		56.5	17.7		49.7	14.4	10.9
Level of Service	C	B		B	B		E	B		D	B	B
Approach Delay (s)		22.0			16.8			18.1			14.3	
Approach LOS		C			B			B			B	

Intersection Summary		
HCM 2000 Control Delay	17.2	HCM 2000 Level of Service
HCM 2000 Volume to Capacity ratio	0.67	B
Actuated Cycle Length (s)	72.2	Sum of lost time (s)
Intersection Capacity Utilization	56.3%	14.5
Analysis Period (min)	15	ICU Level of Service
c Critical Lane Group		B

Intersection						
Int Delay, s/veh	16					
Movement	WBL	WBR	NBT	NBR	SBL	SBT
Lane Configurations	↙	↗	↕		↙	↕
Traffic Vol, veh/h	75	140	1055	60	60	660
Future Vol, veh/h	75	140	1055	60	60	660
Conflicting Peds, #/hr	0	0	0	0	0	0
Sign Control	Stop	Stop	Free	Free	Free	Free
RT Channelized	-	None	-	None	-	None
Storage Length	0	0	-	-	340	-
Veh in Median Storage, #	0	-	0	-	-	0
Grade, %	0	-	0	-	-	0
Peak Hour Factor	86	86	86	86	86	86
Heavy Vehicles, %	7	0	7	2	5	6
Mvmt Flow	87	163	1227	70	70	767

Major/Minor	Minor1	Major1	Major2		
Conflicting Flow All	1786	649	0	0	1297
Stage 1	1262	-	-	-	-
Stage 2	524	-	-	-	-
Critical Hdwy	6.94	6.9	-	-	4.2
Critical Hdwy Stg 1	5.94	-	-	-	-
Critical Hdwy Stg 2	5.94	-	-	-	-
Follow-up Hdwy	3.57	3.3	-	-	2.25
Pot Cap-1 Maneuver	~ 69	417	-	-	514
Stage 1	220	-	-	-	-
Stage 2	545	-	-	-	-
Platoon blocked, %					
Mov Cap-1 Maneuver	~ 60	417	-	-	514
Mov Cap-2 Maneuver	~ 60	-	-	-	-
Stage 1	220	-	-	-	-
Stage 2	471	-	-	-	-

Approach	WB	NB	SB
HCM Control Delay, s	148.4	0	1.1
HCM LOS	F		























Minor Lane/Major Mvmt	NBT	NBRWBLn1	WBLn2	SBL	SBT
Capacity (veh/h)	-	-	60	417	514
HCM Lane V/C Ratio	-	-	1.453	0.39	0.136
HCM Control Delay (s)	-	-	\$ 389.9	19.1	13.1
HCM Lane LOS	-	-	F	C	B
HCM 95th %tile Q(veh)	-	-	7.7	1.8	0.5

Notes  
 ~: Volume exceeds capacity    \$: Delay exceeds 300s    +: Computation Not Defined    \*: All major volume in platoon

# HCM Signalized Intersection Capacity Analysis

## 4: Sequoia Pkwy & Hazeldell Way

03/13/2020

												
Movement	EBL	EBT	EBR	WBL	WBT	WBR	NBL	NBT	NBR	SBL	SBT	SBR
Lane Configurations												
Traffic Volume (vph)	90	10	30	10	20	95	20	110	15	150	100	20
Future Volume (vph)	90	10	30	10	20	95	20	110	15	150	100	20
Ideal Flow (vphpl)	1750	1750	1750	1750	1750	1750	1750	1750	1750	1750	1750	1750
Total Lost time (s)	4.0	4.0	4.0	4.0	4.0		4.0	4.0		4.0	4.0	
Lane Util. Factor	1.00	1.00	1.00	1.00	1.00		1.00	1.00		1.00	1.00	
Frpb, ped/bikes	1.00	1.00	1.00	1.00	0.98		1.00	1.00		1.00	1.00	
Flpb, ped/bikes	1.00	1.00	1.00	1.00	1.00		1.00	1.00		1.00	1.00	
Frt	1.00	1.00	0.85	1.00	0.88		1.00	0.98		1.00	0.98	
Flt Protected	0.95	1.00	1.00	0.95	1.00		0.95	1.00		0.95	1.00	
Satd. Flow (prot)	1614	1750	1488	1662	1432		1511	1560		1662	1490	
Flt Permitted	0.95	1.00	1.00	0.95	1.00		0.95	1.00		0.95	1.00	
Satd. Flow (perm)	1614	1750	1488	1662	1432		1511	1560		1662	1490	
Peak-hour factor, PHF	0.89	0.89	0.89	0.89	0.89	0.89	0.89	0.89	0.89	0.89	0.89	0.89
Adj. Flow (vph)	101	11	34	11	22	107	22	124	17	169	112	22
RTOR Reduction (vph)	0	0	27	0	96	0	0	5	0	0	6	0
Lane Group Flow (vph)	101	11	7	11	33	0	22	136	0	169	128	0
Confl. Peds. (#/hr)	3					3						
Heavy Vehicles (%)	3%	0%	0%	0%	0%	6%	10%	10%	11%	0%	16%	7%
Turn Type	Prot	NA	Perm	Prot	NA		Prot	NA		Prot	NA	
Protected Phases	7	4		3	8		5	2		1	6	
Permitted Phases			4									
Actuated Green, G (s)	6.9	11.2	11.2	1.1	5.4		1.2	15.5		8.6	22.9	
Effective Green, g (s)	6.9	11.2	11.2	1.1	5.4		1.2	15.5		8.6	22.9	
Actuated g/C Ratio	0.13	0.21	0.21	0.02	0.10		0.02	0.30		0.16	0.44	
Clearance Time (s)	4.0	4.0	4.0	4.0	4.0		4.0	4.0		4.0	4.0	
Vehicle Extension (s)	3.0	3.0	3.0	3.0	3.0		3.0	3.0		3.0	3.0	
Lane Grp Cap (vph)	212	374	318	34	147		34	461		272	651	
v/s Ratio Prot	c0.06	0.01		0.01	c0.02		0.01	c0.09		c0.10	0.09	
v/s Ratio Perm			0.00									
v/c Ratio	0.48	0.03	0.02	0.32	0.22		0.65	0.30		0.62	0.20	
Uniform Delay, d1	21.1	16.3	16.3	25.3	21.6		25.4	14.2		20.4	9.1	
Progression Factor	1.00	1.00	1.00	1.00	1.00		1.00	1.00		1.00	1.00	
Incremental Delay, d2	1.7	0.0	0.0	5.5	0.8		35.3	0.4		4.4	0.1	
Delay (s)	22.8	16.3	16.3	30.8	22.4		60.7	14.6		24.7	9.2	
Level of Service	C	B	B	C	C		E	B		C	A	
Approach Delay (s)		20.8			23.0			20.8			17.9	
Approach LOS		C			C			C			B	
<b>Intersection Summary</b>												
HCM 2000 Control Delay			20.0			HCM 2000 Level of Service				C		
HCM 2000 Volume to Capacity ratio			0.40									
Actuated Cycle Length (s)			52.4			Sum of lost time (s)				16.0		
Intersection Capacity Utilization			38.4%			ICU Level of Service				A		
Analysis Period (min)			15									
c Critical Lane Group												

Intersection						
Int Delay, s/veh	1.4					
Movement	WBL	WBR	NBT	NBR	SBL	SBT
Lane Configurations	W		T			T
Traffic Vol, veh/h	10	15	100	25	10	70
Future Vol, veh/h	10	15	100	25	10	70
Conflicting Peds, #/hr	1	0	0	0	0	0
Sign Control	Stop	Stop	Free	Free	Free	Free
RT Channelized	-	None	-	None	-	None
Storage Length	0	-	-	-	-	-
Veh in Median Storage, #	0	-	0	-	-	0
Grade, %	0	-	0	-	-	0
Peak Hour Factor	88	88	92	92	92	92
Heavy Vehicles, %	20	20	6	0	30	3
Mvmt Flow	11	17	109	27	11	76

Major/Minor	Minor1	Major1	Major2		
Conflicting Flow All	222	123	0	0	136
Stage 1	123	-	-	-	-
Stage 2	99	-	-	-	-
Critical Hdwy	6.6	6.4	-	-	4.4
Critical Hdwy Stg 1	5.6	-	-	-	-
Critical Hdwy Stg 2	5.6	-	-	-	-
Follow-up Hdwy	3.68	3.48	-	-	2.47
Pot Cap-1 Maneuver	728	882	-	-	1293
Stage 1	860	-	-	-	-
Stage 2	882	-	-	-	-
Platoon blocked, %			-	-	-
Mov Cap-1 Maneuver	721	882	-	-	1293
Mov Cap-2 Maneuver	724	-	-	-	-
Stage 1	860	-	-	-	-
Stage 2	873	-	-	-	-

Approach	WB	NB	SB
HCM Control Delay, s	9.6	0	1
HCM LOS	A		

Minor Lane/Major Mvmt	NBT	NBRWBLn1	SBL	SBT
Capacity (veh/h)	-	-	811	1293
HCM Lane V/C Ratio	-	-	0.035	0.008
HCM Control Delay (s)	-	-	9.6	7.8
HCM Lane LOS	-	-	A	A
HCM 95th %tile Q(veh)	-	-	0.1	0

Intersection				
Intersection Delay, s/veh	4.1			
Intersection LOS	A			
Approach	EB	WB	NB	SB
Entry Lanes	1	1	1	1
Conflicting Circle Lanes	1	1	1	1
Adj Approach Flow, veh/h	28	92	22	27
Demand Flow Rate, veh/h	36	93	26	27
Vehicles Circulating, veh/h	40	16	24	99
Vehicles Exiting, veh/h	86	34	52	10
Follow-Up Headway, s	3.186	3.186	3.186	3.186
Ped Vol Crossing Leg, #/h	0	0	0	0
Ped Cap Adj	1.000	1.000	1.000	1.000
Approach Delay, s/veh	4.6	4.0	4.1	3.8
Approach LOS	A	A	A	A
Lane	Left	Left	Left	Left
Designated Moves	LTR	LTR	LTR	LTR
Assumed Moves	LTR	LTR	LTR	LTR
RT Channelized				
Lane Util	1.000	1.000	1.000	1.000
Critical Headway, s	5.193	5.193	5.193	5.193
Entry Flow, veh/h	36	93	26	27
Cap Entry Lane, veh/h	1086	1112	1103	1023
Entry HV Adj Factor	0.781	0.987	0.842	0.992
Flow Entry, veh/h	28	92	22	27
Cap Entry, veh/h	848	1097	929	1015
V/C Ratio	0.033	0.084	0.024	0.026
Control Delay, s/veh	4.6	4.0	4.1	3.8
LOS	A	A	A	A
95th %tile Queue, veh	0	0	0	0



Intersection						
Int Delay, s/veh	5.7					
Movement	EBT	EBR	WBL	WBT	NBL	NBR
Lane Configurations						
Traffic Vol, veh/h	15	10	45	65	15	110
Future Vol, veh/h	15	10	45	65	15	110
Conflicting Peds, #/hr	0	0	0	0	0	0
Sign Control	Free	Free	Free	Free	Stop	Stop
RT Channelized	-	None	-	None	-	None
Storage Length	-	-	-	-	0	-
Veh in Median Storage, #	0	-	-	0	0	-
Grade, %	0	-	-	0	0	-
Peak Hour Factor	82	82	82	82	82	82
Heavy Vehicles, %	18	0	0	4	0	0
Mvmt Flow	18	12	55	79	18	134

Major/Minor	Major1	Major2	Minor1		
Conflicting Flow All	0	0	30	0	213 24
Stage 1	-	-	-	-	24 -
Stage 2	-	-	-	-	189 -
Critical Hdwy	-	-	4.1	-	6.4 6.2
Critical Hdwy Stg 1	-	-	-	-	5.4 -
Critical Hdwy Stg 2	-	-	-	-	5.4 -
Follow-up Hdwy	-	-	2.2	-	3.5 3.3
Pot Cap-1 Maneuver	-	-	1596	-	780 1058
Stage 1	-	-	-	-	1004 -
Stage 2	-	-	-	-	848 -
Platoon blocked, %	-	-	-	-	-
Mov Cap-1 Maneuver	-	-	1596	-	752 1058
Mov Cap-2 Maneuver	-	-	-	-	752 -
Stage 1	-	-	-	-	1004 -
Stage 2	-	-	-	-	817 -

Approach	EB	WB	NB
HCM Control Delay, s	0	3	9.2
HCM LOS			A

Minor Lane/Major Mvmt	NBLn1	EBT	EBR	WBL	WBT
Capacity (veh/h)	1009	-	-	1596	-
HCM Lane V/C Ratio	0.151	-	-	0.034	-
HCM Control Delay (s)	9.2	-	-	7.3	0
HCM Lane LOS	A	-	-	A	A
HCM 95th %tile Q(veh)	0.5	-	-	0.1	-

Intersection						
Int Delay, s/veh	2.2					
Movement	WBL	WBR	NBT	NBR	SBL	SBT
Lane Configurations	W		T			T
Traffic Vol, veh/h	30	25	115	10	5	80
Future Vol, veh/h	30	25	115	10	5	80
Conflicting Peds, #/hr	0	0	0	0	0	0
Sign Control	Stop	Stop	Free	Free	Free	Free
RT Channelized	-	None	-	None	-	None
Storage Length	0	-	-	-	-	-
Veh in Median Storage, #	0	-	0	-	-	0
Grade, %	0	-	0	-	-	0
Peak Hour Factor	89	89	89	89	89	89
Heavy Vehicles, %	10	0	3	17	0	4
Mvmt Flow	34	28	129	11	6	90

Major/Minor	Minor1	Major1	Major2		
Conflicting Flow All	237	135	0	0	140
Stage 1	135	-	-	-	-
Stage 2	102	-	-	-	-
Critical Hdwy	6.5	6.2	-	-	4.1
Critical Hdwy Stg 1	5.5	-	-	-	-
Critical Hdwy Stg 2	5.5	-	-	-	-
Follow-up Hdwy	3.59	3.3	-	-	2.2
Pot Cap-1 Maneuver	734	919	-	-	1456
Stage 1	872	-	-	-	-
Stage 2	902	-	-	-	-
Platoon blocked, %			-	-	-
Mov Cap-1 Maneuver	731	919	-	-	1456
Mov Cap-2 Maneuver	731	-	-	-	-
Stage 1	872	-	-	-	-
Stage 2	898	-	-	-	-

Approach	WB	NB	SB
HCM Control Delay, s	9.8	0	0.4
HCM LOS	A		

Minor Lane/Major Mvmt	NBT	NBRWBLn1	SBL	SBT
Capacity (veh/h)	-	-	806	1456
HCM Lane V/C Ratio	-	-	0.077	0.004
HCM Control Delay (s)	-	-	9.8	7.5
HCM Lane LOS	-	-	A	A
HCM 95th %tile Q(veh)	-	-	0.2	0

HCM Signalized Intersection Capacity Analysis  
 1: OR 99E & Redwood St/Sequoia Pkwy

03/13/2020



Movement	EBL	EBT	EBR	WBL	WBT	WBR	NBL	NBT	NBR	SBL	SBT	SBR
Lane Configurations	↶	↷		↶↷	↶	↷	↶	↶↷	↷	↶	↶↷	
Traffic Volume (vph)	5	70	40	390	65	130	60	770	155	140	1030	20
Future Volume (vph)	5	70	40	390	65	130	60	770	155	140	1030	20
Ideal Flow (vphpl)	1750	1750	1750	1750	1750	1750	1750	1750	1750	1750	1750	1750
Total Lost time (s)	4.0	4.0		4.0	4.0	4.0	4.0	5.4	5.4	4.0	5.4	
Lane Util. Factor	1.00	1.00		0.97	1.00	1.00	1.00	0.95	1.00	1.00	0.95	
Frt	1.00	0.95		1.00	1.00	0.85	1.00	1.00	0.85	1.00	1.00	
Flt Protected	0.95	1.00		0.95	1.00	1.00	0.95	1.00	1.00	0.95	1.00	
Satd. Flow (prot)	1662	1615		3193	1750	1430	1599	3167	1430	1646	3190	
Flt Permitted	0.95	1.00		0.95	1.00	1.00	0.95	1.00	1.00	0.95	1.00	
Satd. Flow (perm)	1662	1615		3193	1750	1430	1599	3167	1430	1646	3190	
Peak-hour factor, PHF	0.91	0.91	0.91	0.91	0.91	0.91	0.91	0.91	0.91	0.91	0.91	0.91
Adj. Flow (vph)	5	77	44	429	71	143	66	846	170	154	1132	22
RTOR Reduction (vph)	0	20	0	0	0	119	0	0	100	0	1	0
Lane Group Flow (vph)	5	101	0	429	71	24	66	846	70	154	1153	0
Heavy Vehicles (%)	0%	1%	5%	1%	0%	4%	4%	5%	4%	1%	4%	0%
Turn Type	Split	NA		Split	NA	Perm	Prot	NA	Perm	Prot	NA	
Protected Phases	8	8		4	4		1	6		5	2	
Permitted Phases						4			6			
Actuated Green, G (s)	10.5	10.5		15.3	15.3	15.3	6.9	38.0	38.0	11.0	42.1	
Effective Green, g (s)	10.5	10.5		15.3	15.3	15.3	6.9	38.0	38.0	11.0	42.1	
Actuated g/C Ratio	0.11	0.11		0.17	0.17	0.17	0.07	0.41	0.41	0.12	0.46	
Clearance Time (s)	4.0	4.0		4.0	4.0	4.0	4.0	5.4	5.4	4.0	5.4	
Vehicle Extension (s)	2.3	2.3		2.3	2.3	2.3	2.3	5.5	5.5	2.3	5.5	
Lane Grp Cap (vph)	189	183		529	290	237	119	1305	589	196	1456	
v/s Ratio Prot	0.00	c0.06		c0.13	0.04		0.04	0.27		c0.09	c0.36	
v/s Ratio Perm						0.02			0.05			
v/c Ratio	0.03	0.55		0.81	0.24	0.10	0.55	0.65	0.12	0.79	0.79	
Uniform Delay, d1	36.3	38.6		37.1	33.4	32.6	41.2	21.7	16.8	39.5	21.3	
Progression Factor	1.00	1.00		1.00	1.00	1.00	1.00	1.00	1.00	1.00	1.00	
Incremental Delay, d2	0.0	2.3		8.9	0.3	0.1	3.9	1.7	0.2	17.6	3.6	
Delay (s)	36.3	40.9		45.9	33.7	32.7	45.1	23.4	17.0	57.0	24.9	
Level of Service	D	D		D	C	C	D	C	B	E	C	
Approach Delay (s)		40.8			41.6			23.7			28.7	
Approach LOS		D			D			C			C	

Intersection Summary		
HCM 2000 Control Delay	30.1	HCM 2000 Level of Service
HCM 2000 Volume to Capacity ratio	0.79	C
Actuated Cycle Length (s)	92.2	Sum of lost time (s)
Intersection Capacity Utilization	65.1%	ICU Level of Service
Analysis Period (min)	15	C
c Critical Lane Group		

HCM Signalized Intersection Capacity Analysis  
 2: OR 99 E & NE Territorial Rd/SE Territorial Rd

03/13/2020



Movement	EBL	EBT	EBR	WBL	WBT	WBR	NBL	NBT	NBR	SBL	SBT	SBR
Lane Configurations	↖	↗		↖	↗		↖	↕		↖	↗	↖
Traffic Volume (vph)	185	20	25	15	30	5	30	995	15	5	1075	260
Future Volume (vph)	185	20	25	15	30	5	30	995	15	5	1075	260
Ideal Flow (vphpl)	1750	1750	1750	1750	1750	1750	1750	1750	1750	1750	1750	1750
Total Lost time (s)	4.5	4.5		4.5	4.5		4.0	6.0		4.0	6.0	6.0
Lane Util. Factor	1.00	1.00		1.00	1.00		1.00	0.95		1.00	0.95	1.00
Frt	1.00	0.92		1.00	0.98		1.00	1.00		1.00	1.00	0.85
Flt Protected	0.95	1.00		0.95	1.00		0.95	1.00		0.95	1.00	1.00
Satd. Flow (prot)	1646	1562		1554	1714		1662	3185		1330	3167	1473
Flt Permitted	0.73	1.00		0.73	1.00		0.95	1.00		0.95	1.00	1.00
Satd. Flow (perm)	1271	1562		1188	1714		1662	3185		1330	3167	1473
Peak-hour factor, PHF	0.96	0.96	0.96	0.96	0.96	0.96	0.96	0.96	0.96	0.96	0.96	0.96
Adj. Flow (vph)	193	21	26	16	31	5	31	1036	16	5	1120	271
RTOR Reduction (vph)	0	20	0	0	4	0	0	1	0	0	0	123
Lane Group Flow (vph)	193	27	0	16	32	0	31	1051	0	5	1120	148
Heavy Vehicles (%)	1%	0%	5%	7%	0%	0%	0%	4%	15%	25%	5%	1%
Turn Type	Perm	NA		Perm	NA		Prot	NA		Prot	NA	Perm
Protected Phases		8			4		1	6		5	2	
Permitted Phases	8			4								2
Actuated Green, G (s)	19.0	19.0		19.0	19.0		3.8	47.6		0.9	44.7	44.7
Effective Green, g (s)	19.0	19.0		19.0	19.0		3.8	47.6		0.9	44.7	44.7
Actuated g/C Ratio	0.23	0.23		0.23	0.23		0.05	0.58		0.01	0.55	0.55
Clearance Time (s)	4.5	4.5		4.5	4.5		4.0	6.0		4.0	6.0	6.0
Vehicle Extension (s)	2.5	2.5		2.5	2.5		2.3	5.4		2.3	5.4	5.4
Lane Grp Cap (vph)	294	361		275	397		77	1848		14	1726	802
v/s Ratio Prot		0.02			0.02		c0.02	c0.33		0.00	c0.35	
v/s Ratio Perm	c0.15			0.01								0.10
v/c Ratio	0.66	0.07		0.06	0.08		0.40	0.57		0.36	0.65	0.18
Uniform Delay, d1	28.5	24.6		24.5	24.7		38.0	10.8		40.3	13.1	9.4
Progression Factor	1.00	1.00		1.00	1.00		1.00	1.00		1.00	1.00	1.00
Incremental Delay, d2	4.7	0.1		0.1	0.1		2.0	0.7		8.9	1.3	0.3
Delay (s)	33.2	24.7		24.6	24.7		40.0	11.5		49.1	14.4	9.7
Level of Service	C	C		C	C		D	B		D	B	A
Approach Delay (s)		31.5			24.7			12.3			13.6	
Approach LOS		C			C			B			B	

Intersection Summary		
HCM 2000 Control Delay	14.9	HCM 2000 Level of Service
HCM 2000 Volume to Capacity ratio	0.63	B
Actuated Cycle Length (s)	82.0	Sum of lost time (s)
Intersection Capacity Utilization	58.8%	14.5
Analysis Period (min)	15	ICU Level of Service
c Critical Lane Group		B

Intersection						
Int Delay, s/veh	10.9					
Movement	WBL	WBR	NBT	NBR	SBL	SBT
Lane Configurations	↘	↗	↕		↘	↗
Traffic Vol, veh/h	50	75	1030	100	140	1295
Future Vol, veh/h	50	75	1030	100	140	1295
Conflicting Peds, #/hr	0	0	0	0	0	0
Sign Control	Stop	Stop	Free	Free	Free	Free
RT Channelized	-	None	-	None	-	None
Storage Length	0	0	-	-	340	-
Veh in Median Storage, #	0	-	0	-	-	0
Grade, %	0	-	0	-	-	0
Peak Hour Factor	96	96	96	96	96	96
Heavy Vehicles, %	2	1	2	1	0	3
Mvmt Flow	52	78	1073	104	146	1349

Major/Minor	Minor1	Major1	Major2		
Conflicting Flow All	2092	589	0	0	1177
Stage 1	1125	-	-	-	-
Stage 2	967	-	-	-	-
Critical Hdwy	6.84	6.92	-	-	4.1
Critical Hdwy Stg 1	5.84	-	-	-	-
Critical Hdwy Stg 2	5.84	-	-	-	-
Follow-up Hdwy	3.52	3.31	-	-	2.2
Pot Cap-1 Maneuver	~ 45	454	-	-	601
Stage 1	272	-	-	-	-
Stage 2	329	-	-	-	-
Platoon blocked, %					
Mov Cap-1 Maneuver	~ 34	454	-	-	601
Mov Cap-2 Maneuver	~ 34	-	-	-	-
Stage 1	272	-	-	-	-
Stage 2	249	-	-	-	-

Approach	WB	NB	SB
HCM Control Delay, s	219.2	0	1.3
HCM LOS	F		

Minor Lane/Major Mvmt	NBT	NBRWBLn1	WBLn2	SBL	SBT
Capacity (veh/h)	-	-	34	454	601
HCM Lane V/C Ratio	-	-	1.532	0.172	0.243
HCM Control Delay (s)	-	-	\$ 526	14.6	12.9
HCM Lane LOS	-	-	F	B	B
HCM 95th %tile Q(veh)	-	-	5.7	0.6	0.9

Notes  
 ~: Volume exceeds capacity    \$: Delay exceeds 300s    +: Computation Not Defined    \*: All major volume in platoon



# HCM Signalized Intersection Capacity Analysis

## 4: Sequoia Pkwy & Hazeldell Way

04/08/2020



Movement	EBL	EBT	EBR	WBL	WBT	WBR	NBL	NBT	NBR	SBL	SBT	SBR
Lane Configurations												
Traffic Volume (vph)	275	25	15	20	30	170	65	140	10	130	125	55
Future Volume (vph)	275	25	15	20	30	170	65	140	10	130	125	55
Ideal Flow (vphp)	1750	1750	1750	1750	1750	1750	1750	1750	1750	1750	1750	1750
Total Lost time (s)	4.0	4.0	4.0	4.0	4.0		4.0	4.0		4.0	4.0	
Lane Util. Factor	1.00	1.00	1.00	1.00	1.00		1.00	1.00		1.00	1.00	
Frt	1.00	1.00	0.85	1.00	0.87		1.00	0.99		1.00	0.95	
Flt Protected	0.95	1.00	1.00	0.95	1.00		0.95	1.00		0.95	1.00	
Satd. Flow (prot)	1646	1750	1488	1662	1502		1662	1700		1614	1647	
Flt Permitted	0.95	1.00	1.00	0.95	1.00		0.95	1.00		0.95	1.00	
Satd. Flow (perm)	1646	1750	1488	1662	1502		1662	1700		1614	1647	
Peak-hour factor, PHF	0.95	0.95	0.95	0.95	0.95	0.95	0.95	0.95	0.95	0.95	0.95	0.95
Adj. Flow (vph)	289	26	16	21	32	179	68	147	11	137	132	58
RTOR Reduction (vph)	0	0	10	0	156	0	0	3	0	0	15	0
Lane Group Flow (vph)	289	26	6	21	55	0	68	155	0	137	175	0
Heavy Vehicles (%)	1%	0%	0%	0%	0%	2%	0%	2%	0%	3%	2%	0%
Turn Type	Prot	NA	Perm	Prot	NA		Prot	NA		Prot	NA	
Protected Phases	7	4		3	8		5	2		1	6	
Permitted Phases			4									
Actuated Green, G (s)	16.4	23.3	23.3	1.2	8.1		4.3	14.0		8.3	18.0	
Effective Green, g (s)	16.4	23.3	23.3	1.2	8.1		4.3	14.0		8.3	18.0	
Actuated g/C Ratio	0.26	0.37	0.37	0.02	0.13		0.07	0.22		0.13	0.29	
Clearance Time (s)	4.0	4.0	4.0	4.0	4.0		4.0	4.0		4.0	4.0	
Vehicle Extension (s)	3.0	3.0	3.0	3.0	3.0		3.0	3.0		3.0	3.0	
Lane Grp Cap (vph)	429	649	552	31	193		113	378		213	472	
v/s Ratio Prot	c0.18	0.01		0.01	c0.04		0.04	0.09		c0.08	c0.11	
v/s Ratio Perm			0.00									
v/c Ratio	0.67	0.04	0.01	0.68	0.29		0.60	0.41		0.64	0.37	
Uniform Delay, d1	20.8	12.6	12.5	30.6	24.7		28.4	20.9		25.8	17.9	
Progression Factor	1.00	1.00	1.00	1.00	1.00		1.00	1.00		1.00	1.00	
Incremental Delay, d2	4.1	0.0	0.0	45.6	0.8		8.7	0.7		6.5	0.5	
Delay (s)	24.9	12.6	12.5	76.2	25.6		37.1	21.6		32.3	18.4	
Level of Service	C	B	B	E	C		D	C		C	B	
Approach Delay (s)		23.4			30.1			26.3			24.2	
Approach LOS		C			C			C			C	

Intersection Summary		
HCM 2000 Control Delay	25.6	HCM 2000 Level of Service C
HCM 2000 Volume to Capacity ratio	0.51	
Actuated Cycle Length (s)	62.8	Sum of lost time (s) 16.0
Intersection Capacity Utilization	59.5%	ICU Level of Service B
Analysis Period (min)	15	
c Critical Lane Group		

Intersection						
Int Delay, s/veh	0.9					
Movement	WBL	WBR	NBT	NBR	SBL	SBT
Lane Configurations						
Traffic Vol, veh/h	30	5	120	15	5	270
Future Vol, veh/h	30	5	120	15	5	270
Conflicting Peds, #/hr	0	0	0	0	0	0
Sign Control	Stop	Stop	Free	Free	Free	Free
RT Channelized	-	None	-	None	-	None
Storage Length	0	-	-	-	-	-
Veh in Median Storage, #	0	-	0	-	-	0
Grade, %	0	-	0	-	-	0
Peak Hour Factor	84	84	84	84	84	84
Heavy Vehicles, %	0	0	1	17	0	1
Mvmt Flow	36	6	143	18	6	321

Major/Minor	Minor1	Major1	Major2		
Conflicting Flow All	485	152	0	0	161
Stage 1	152	-	-	-	-
Stage 2	333	-	-	-	-
Critical Hdwy	6.4	6.2	-	-	4.1
Critical Hdwy Stg 1	5.4	-	-	-	-
Critical Hdwy Stg 2	5.4	-	-	-	-
Follow-up Hdwy	3.5	3.3	-	-	2.2
Pot Cap-1 Maneuver	545	900	-	-	1430
Stage 1	881	-	-	-	-
Stage 2	731	-	-	-	-
Platoon blocked, %			-	-	-
Mov Cap-1 Maneuver	542	900	-	-	1430
Mov Cap-2 Maneuver	604	-	-	-	-
Stage 1	881	-	-	-	-
Stage 2	727	-	-	-	-

Approach	WB	NB	SB
HCM Control Delay, s	11.1	0	0.1
HCM LOS	B		

Minor Lane/Major Mvmt	NBT	NBRWBLn1	SBL	SBT
Capacity (veh/h)	-	-	634	1430
HCM Lane V/C Ratio	-	-	0.066	0.004
HCM Control Delay (s)	-	-	11.1	7.5
HCM Lane LOS	-	-	B	A
HCM 95th %tile Q(veh)	-	-	0.2	0

Intersection				
Intersection Delay, s/veh	4.1			
Intersection LOS	A			
Approach	EB	WB	NB	SB
Entry Lanes	1	1	1	1
Conflicting Circle Lanes	1	1	1	1
Adj Approach Flow, veh/h	110	70	51	10
Demand Flow Rate, veh/h	113	72	53	10
Vehicles Circulating, veh/h	19	39	107	78
Vehicles Exiting, veh/h	69	121	25	33
Follow-Up Headway, s	3.186	3.186	3.186	3.186
Ped Vol Crossing Leg, #/h	0	0	0	0
Ped Cap Adj	1.000	1.000	1.000	1.000
Approach Delay, s/veh	4.2	4.0	4.2	3.6
Approach LOS	A	A	A	A
Lane	Left	Left	Left	Left
Designated Moves	LTR	LTR	LTR	LTR
Assumed Moves	LTR	LTR	LTR	LTR
RT Channelized				
Lane Util	1.000	1.000	1.000	1.000
Critical Headway, s	5.193	5.193	5.193	5.193
Entry Flow, veh/h	113	72	53	10
Cap Entry Lane, veh/h	1109	1087	1015	1045
Entry HV Adj Factor	0.975	0.972	0.954	0.990
Flow Entry, veh/h	110	70	51	10
Cap Entry, veh/h	1081	1057	969	1035
V/C Ratio	0.102	0.066	0.052	0.010
Control Delay, s/veh	4.2	4.0	4.2	3.6
LOS	A	A	A	A
95th %tile Queue, veh	0	0	0	0

Intersection						
Int Delay, s/veh	4.7					
Movement	EBT	EBR	WBL	WBT	NBL	NBR
Lane Configurations						
Traffic Vol, veh/h	85	15	125	50	10	55
Future Vol, veh/h	85	15	125	50	10	55
Conflicting Peds, #/hr	0	0	0	0	0	0
Sign Control	Free	Free	Free	Free	Stop	Stop
RT Channelized	-	None	-	None	-	None
Storage Length	-	-	-	-	0	-
Veh in Median Storage, #	0	-	-	0	0	-
Grade, %	0	-	-	0	0	-
Peak Hour Factor	86	86	86	86	86	86
Heavy Vehicles, %	3	20	0	3	0	0
Mvmt Flow	99	17	145	58	12	64

Major/Minor	Major1	Major2	Minor1		
Conflicting Flow All	0	0	116	0	456
Stage 1	-	-	-	-	108
Stage 2	-	-	-	-	348
Critical Hdwy	-	-	4.1	-	6.4
Critical Hdwy Stg 1	-	-	-	-	5.4
Critical Hdwy Stg 2	-	-	-	-	5.4
Follow-up Hdwy	-	-	2.2	-	3.5
Pot Cap-1 Maneuver	-	-	1485	-	566
Stage 1	-	-	-	-	921
Stage 2	-	-	-	-	719
Platoon blocked, %	-	-	-	-	-
Mov Cap-1 Maneuver	-	-	1485	-	509
Mov Cap-2 Maneuver	-	-	-	-	509
Stage 1	-	-	-	-	921
Stage 2	-	-	-	-	646

Approach	EB	WB	NB
HCM Control Delay, s	0	5.5	9.7
HCM LOS			A

Minor Lane/Major Mvmt	NBLn1	EBT	EBR	WBL	WBT
Capacity (veh/h)	839	-	-	1485	-
HCM Lane V/C Ratio	0.09	-	-	0.098	-
HCM Control Delay (s)	9.7	-	-	7.7	0
HCM Lane LOS	A	-	-	A	A
HCM 95th %tile Q(veh)	0.3	-	-	0.3	-

Intersection						
Int Delay, s/veh	1.2					
Movement	WBL	WBR	NBT	NBR	SBL	SBT
Lane Configurations	W		T			T
Traffic Vol, veh/h	15	15	100	40	15	160
Future Vol, veh/h	15	15	100	40	15	160
Conflicting Peds, #/hr	0	0	0	0	0	0
Sign Control	Stop	Stop	Free	Free	Free	Free
RT Channelized	-	None	-	None	-	None
Storage Length	0	-	-	-	-	-
Veh in Median Storage, #	0	-	0	-	-	0
Grade, %	0	-	0	-	-	0
Peak Hour Factor	89	89	89	89	89	89
Heavy Vehicles, %	13	0	1	6	7	5
Mvmt Flow	17	17	112	45	17	180

Major/Minor	Minor1	Major1	Major2		
Conflicting Flow All	349	135	0	0	157
Stage 1	135	-	-	-	-
Stage 2	214	-	-	-	-
Critical Hdwy	6.53	6.2	-	-	4.17
Critical Hdwy Stg 1	5.53	-	-	-	-
Critical Hdwy Stg 2	5.53	-	-	-	-
Follow-up Hdwy	3.617	3.3	-	-	2.263
Pot Cap-1 Maneuver	627	919	-	-	1393
Stage 1	865	-	-	-	-
Stage 2	796	-	-	-	-
Platoon blocked, %					
Mov Cap-1 Maneuver	618	919	-	-	1393
Mov Cap-2 Maneuver	618	-	-	-	-
Stage 1	865	-	-	-	-
Stage 2	785	-	-	-	-

Approach	WB	NB	SB
HCM Control Delay, s	10.1	0	0.7
HCM LOS	B		

Minor Lane/Major Mvmt	NBT	NBRWBLn1	SBL	SBT
Capacity (veh/h)	-	-	739	1393
HCM Lane V/C Ratio	-	-	0.046	0.012
HCM Control Delay (s)	-	-	10.1	7.6
HCM Lane LOS	-	-	B	A
HCM 95th %tile Q(veh)	-	-	0.1	0



## **Crash Data (2015-2017)**

---

FID	OBJECTID	CRASH_ID	CRASH_DT	RTE_NM	HWY_NO	CRASH_TYP1	COLLIS_T_1	CRASH_SV_1	WTHR_COND1	RD_SURF_ME	LGT_COND_L	TRAF_CNTL1	CRASH_CA_1
0	137913	1739436	2017-07-15	OR 99E	081	Entering at angle - all others	Turning movement	Non-Fatal Injury	Clear	Dry	Daylight	Stop Sign	Did not yield right-of-way
1	141760	1744019	2017-09-14	OR 99E	081	Entering at angle - all others	Turning movement	Non-Fatal Injury	Clear	Dry	Daylight	Stop Sign	Did not yield right-of-way
2	144334	1755298	2017-05-15			Entering at angle - all others	Angle	Property Damage Only	Clear	Dry	Daylight	Stop Sign	Passed stop sign or red flasher
3	146635	1747473	2017-11-30	OR 99E	081	Fixed Object	Fixed Object or Other Object	Non-Fatal Injury	Fog	Wet	Daylight	Stop Sign	Phantom / Non-contact Vehicle
4	153655	1760151	2017-08-15	OR 99E	081	From opposite direction-one left turn,one straight	Turning movement	Property Damage Only	Clear	Dry	Daylight	Traffic Signals	Did not yield right-of-way
5	156968	1737881	2017-06-30	OR 99E	081	Entering at angle - all others	Angle	Non-Fatal Injury	Clear	Dry	Daylight	Traffic Signals	Disregarded traffic signal
6	166537	1732859	2017-04-18	OR 99E	081	From same direction - one stopped	Rear-End	Non-Fatal Injury	Clear	Dry	Daylight	Traffic Signals	Followed too closely
0	5406	1661752	2016-02-26	OR 99E	081	From same direction - one stopped	Rear-End	Non-Fatal Injury	Rain	Wet	Daylight	Traffic Signals	Failed to avoid vehicle ahead
1	11984	1668383	2016-05-03	OR 99E	081	From same direction - one stopped	Rear-End	Non-Fatal Injury	Clear	Dry	Daylight	Traffic Signals	Followed too closely
2	15031	1671451	2016-06-03	OR 99E	081	Entering at angle - all others	Turning movement	Non-Fatal Injury	Clear	Dry	Daylight	Stop Sign	Did not yield right-of-way
3	18274	1674718	2016-07-01	OR 99E	081	Entering at angle - all others	Turning movement	Non-Fatal Injury	Clear	Dry	Daylight	Stop Sign	Did not yield right-of-way
4	30432	1686918	2016-12-08	OR 99E	081	From same direction - both going straight	Rear-End	Non-Fatal Injury	Rain	Wet	Daylight	Traffic Signals	Other improper driving
5	30568	1687054	2016-05-31	OR 99E	081	From same direction - one stopped	Rear-End	Non-Fatal Injury	Clear	Dry	Daylight	Traffic Signals	Failed to avoid vehicle ahead
6	43440	1700117	2016-06-02	OR 99E	081	From opposite direction-one left turn,one straight	Turning movement	Property Damage Only	Rain	Wet	Daylight	Traffic Signals	Did not yield right-of-way
7	45830	1702521	2016-07-10			Entering at angle - all others	Turning movement	Property Damage Only	Cloudy	Dry	Daylight	Stop Sign	Did not yield right-of-way
8	57416	1714229	2016-12-03	OR 99E	081	Fixed Object	Fixed Object or Other Object	Property Damage Only	Rain	Wet	Darkness - with street lights	No control	Disregarded traffic signal
0	1066	1601971	2015-01-19	OR 99E	081	Entering at angle - all others	Turning movement	Non-Fatal Injury	Cloudy	Wet	Darkness - no street lights	Flashing Beacon	Did not yield right-of-way
1	1525	1602430	2015-01-29	OR 99E	081	From opposite direction - one turn, one straight	Turning movement	Non-Fatal Injury	Clear	Dry	Daylight	Traffic Signals	Disregarded R-A-G traffic signal.
2	3888	1604796	2015-03-23			From same direction - one stopped	Rear-End	Non-Fatal Injury	UnknownWet		Daylight	Stop Sign	
3	5851	1606769	2015-04-21	OR 99E	081	From opposite direction - one turn, one straight	Turning movement	Non-Fatal Injury	UnknownWet		Daylight	Traffic Signals	Did not yield right-of-way
4	8373	1609299	2015-05-20	OR 99E	081	From same direction - both going straight	Rear-End	Non-Fatal Injury	Cloudy	Dry	Daylight	Traffic Signals	
5	20859	1621828	2015-09-19			From opposite direction - one turn, one straight	Turning movement	Non-Fatal Injury	Clear	Dry	Daylight	Stop Sign	Did not yield right-of-way
6	23072	1624048	2015-10-15	OR 99E	081	From opposite direction - one turn, one straight	Turning movement	Non-Fatal Injury	Clear	Dry	Darkness - with street lights	Traffic Signals	Disregarded R-A-G traffic signal.
7	27211	1628196	2015-12-08	OR 99E	081	Entering at angle - all others	Turning movement	Non-Fatal Injury	Rain	Wet	Darkness - no street lights	Stop Sign	Did not yield right-of-way
8	28307	1629295	2015-12-24	OR 99E	081	From same direction - one stopped	Rear-End	Non-Fatal Injury	Rain	Wet	Daylight	Traffic Signals	
9	34134	1635132	2015-03-13	OR 99E	081	From opposite direction - one turn, one straight	Turning movement	Property Damage Only	UnknownWet		Daylight	Traffic Signals	Disregarded R-A-G traffic signal.
10	46384	1647504	2015-09-17	OR 99E	081	From same direction - one turn, one straight	Turning movement	Property Damage Only	Clear	Dry	Darkness - with street lights	Traffic Signals	Made improper turn
11	50319	1651507	2015-12-30	OR 99E	081	Entering at angle - all others	Turning movement	Property Damage Only	Clear	Dry	Dusk (Twilight)	Flashing Beacon	Did not yield right-of-way

CITY OF CANBY —COMMENT FORM

If you are unable to attend the Public Hearings, you may submit written comments on this form or in a letter. Please send comments to the City of Canby Planning Department:

- By mail: Planning Department, PO Box 930, Canby, OR 97013
- In person: Planning Department at 222 NE Second Street *(Provided COVID-19 restrictions have been lifted.)*
- E-mail: [PublicComments@canbyoregon.eov](mailto:PublicComments@canbyoregon.eov)

Written comments to be included in Planning Commission packet are due by Wednesday, July 29, 2020. Written and oral comments can be submitted up to the time of the Public Hearing and may also be delivered in person during the Public Hearing. If you would like to testify during the meeting, please contact the Recording Secretary no later than noon, Monday, July 27, 2020 by calling 503-266-0685 or emailing [fousel@canbyoregon.eov](mailto:fousel@canbyoregon.eov) to request a Zoom invite. Application: DR 20-02/PAR20-01

COMMENTS:

Zoar Lutheran Church owns the property just south of the proposed development, known as Zoar Cemetery.

Zoar would like the Cemetery to continue to be a place where families and friends may visit the graves. During construction we want the property protected from the debris and sediments of construction. We don't want the Cemetery used as a parking lot or storage area.

All of the Zoar properties are No Smoking and we want that maintained during and after construction. We do not have the facilities for dealing with additional trash, lunch waste or waste from tobacco products. Please provide someone that we can contact if there are any issues with misuse of the property.

There are many trees on the property and we want those left alone. If there is any damage, there needs to be a way to make sure that the trees are cared for. There are still unused burial sites at that cemetery, and we will continue to do burials there.

Over the last few years, there has been some comments that there are burials outside of the property lines. Try as we have, we cannot prove that this is true. If there is a concern, Zoar would be glad to have those strips of land donated to the Church and we will maintain those areas like we do the other burial areas. If they happen to find a grave site during construction, we would like to be notified.

CITIZEN NAME: Steven B. Morgan Council President for Zoar Lutheran Church

EMAIL: smorgan@DCS-Morgan.com

ADDRESS: 190 SW 3<sup>rd</sup> Ave. Canby Or. 97013

PHONE # (optional): 503-266-4061

DATE: July 27 2020

PLEASE EMAIL COMMENTS TO  
[PublicComments@canbyoregon.gov](mailto:PublicComments@canbyoregon.gov)

AGENCIES. • Please check one box and fill in Your Name/Agency/Date below:

- Adequate Public Services (of your agency) are available
- Adequate Public Services will become available through the development
- Conditions are needed, as indicated
- Adequate public services are not available and will not become available
- No Comments

NAME: \_\_\_\_\_

AGENCY: \_\_\_\_\_

DATE: \_\_\_\_\_

Thank you!

July 16, 2020

**MEMORANDUM**

**TO:** Public Comments  
City of Canby

**FROM:** Hassan Ibrahim, PE  
Curran-Mcleod, Inc.

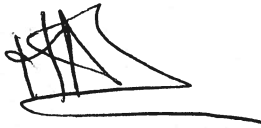

**RE: CITY OF CANBY  
BAKER CENTER DEVELOPMENT  
APPLICATION REVIEW (DR 20-02/PAR 20-02)**

We have reviewed the submitted application and plans for the above noted project and have the following comments which should be addressed in the final design:

SE 1<sup>st</sup> Avenue:

1. This roadway section is under the City of Canby jurisdiction. The street classification has been updated from a Local street to an Industrial Collector street. The existing right of way is 40 feet or 20 feet on each side of the centerline. The developer shall be required to dedicate an additional 17 feet of right of way. Half street improvements shall be required along the entire site frontage where the curb line is placed at 25 feet from the right of way centerline, with 5-foot planter strip and 6-foot wide concrete sidewalk, street lights and street trees will also be required. We recommend the City require a minimum of 12-foot wide PUE abutting the new right of way dedication.
2. The industrial park concept is to internalize all industrial traffic and avoid conflict with the adjoining residential areas. We think this can be achieved by completing the half street improvements along S. Walnut Street from the current terminus to SE 1<sup>st</sup> Avenue and ultimately to Highway 99E. Accordingly, although it is the County's jurisdiction, we also recommend all driveway accesses be allowed to SE 1<sup>st</sup> Avenue for this industrial development so that the traffic pattern can be internalized.
3. The curb return radii at intersections and driveways should be large enough to allow for AASHTO WB-67 vehicle turning movements. The property line should be concentric with this return. The applicant engineer shall submit to the City truck turning movements templates demonstrating that the turning movement requirements are met.

4. All driveways shall have an industrial driveway approach consisting of 8" minimum concrete thickness with reinforcements or mesh welded wire fabric.
5. The minimum centerline horizontal radius for a collector street should be 270 feet.
6. Sanitary sewer shall be extended from Hazel Dell Way to the intersection with S Walnut Street. The location of the manhole shall not conflict with the turnabout configuration while the depth of the manhole at S Walnut Street needs to be a minimum of 14 feet to accommodate serving the properties on both sides of the future S. Walnut Street extension to Hwy 99E.
7. A public 8" sewer line shall be extended along the westerly property line of this parcel and extended to the southerly property line, terminating with a minimum 8-foot deep manhole to serve the remaining undeveloped properties to the south.
8. Right of way dedication shall be required at the intersection of SE 1<sup>st</sup> Avenue and S Walnut Street to accommodate the future turnabout as part of S Walnut Street extension to Hwy 99E.

S. Walnut Street:

1. This roadway segment is under the jurisdiction of City of Canby. The City of Canby, Industrial Area Master Plan prepared by OTAK Engineering, dated October 1998 and the City Transportation System Plan refer to this roadway as a local street section. We recommend this roadway be constructed to local street standards as per the Public Works design Standards, chapter 2, section 2.207. We recommend half street improvements be constructed along the entire site frontage from the south terminus half street improvements to SE 1<sup>st</sup> Avenue to match the ultimate existing paved street width of 32 feet to include-foot planter strip and 6-foot wide concrete sidewalk. Right of way dedications may be required to accommodate the half street improvements. We recommend the City require a 12-foot wide PUE.
2. With the narrow roadway width, access driveways along Walnut Street should be industrial type with large radius curb returns to account for truck traffic. Public sidewalks should extend across the driveways.
3. The City Transportation System Plan does not impose any access spacing limitations on local street nor have we seen any requirement to align driveways or meet spacing requirements across the streets. Driveway locations appears to be acceptable and the driveway width shall be a maximum of 40 feet wide as per City of Canby Municipal Code.



4. All driveways shall have an industrial driveway approach consisting of 8" minimum concrete thickness with reinforcements or mesh welded wire fabric.
5. The curb return radii at intersections and driveways should be large enough to allow for AASHTO WB-67 vehicle turning movements. The property line should be concentric with this return. The applicant engineer shall submit to the City truck turning movement templates demonstrating that the turning movement requirements are met.

Miscellaneous:

1. All private storm drainage discharge shall be disposed on-site, the design methodology shall be in conformance with the City of Canby, June 2012 Public Works Standards.
2. No storm drainage analysis or plans are submitted with this development. The developer's engineer will be required to demonstrate how the storm runoff generated from the new impervious surfaces will be disposed. If drywells (UIC) are used as a means to discharge storm runoff from the private streets, they must meet the following criteria: The UIC structures location shall meet at least one of the two conditions: (1) the vertical separation distance between the UIC and seasonal high groundwater is more than 2.5 feet or (2) the horizontal separation distance between the UIC and any water well is a minimum of 267 feet in accordance of the City of Canby Stormwater Master Plan, Appendix "C", Groundwater Protectiveness Demonstration and Risk Prioritization for Underground Injection Control (UIC) Devices. The storm drainage report shall be in conformance with the requirements as stated in Chapter 4 of the City of Canby Public Works Design Standards dated June 2012.
3. Any existing domestic or irrigation wells shall be abandoned in conformance with OAR 690-220-0030. A copy of Oregon water Rights Department (OWRD) abandonment certificate shall be submitted to the City.
4. Any existing on-site sewage disposal system shall be abandoned in conformance with DEQ and Clackamas County Water Environmental Services (WES) regulations. A copy of the septic tank removal certificate shall be submitted to the City.
5. Water Services/ Fire Protection shall also be constructed in conformance with Canby Utility and Canby Fire Department requirements.

Should you have any questions or need additional information, please let me know.



# CANBY FIRE DISTRICT

Baker Center Project @ SE 1<sup>st</sup> Avenue between S Hazel Dell Way and S Walnut Street.

The Project shall comply with the following reference material and items to be addressed.

References:

Oregon Fire Code

NFPA references for the application and installation of all systems.

Chapter 33 of the Oregon Fire Code for construction needs to be reviewed prior. - Hydrants installed and fire flow done prior to flammable construction materials on site,

Chapter 22 of the Oregon Fire Code Combustible Dust Producing operation

Mobile Emergency Radio Communications plan for 50 K square feet and above.

Building Address @ 24 inch and contrasting with numbers an corners of the building

Alarm Panel enunciator at the front entry of Fire Riser door depending on building configuration

Knox Box at front entry or riser room doors = area determined during construction. Locate at

<https://www.knoxbox.com/>

Hydrant at the entry or entries and locations of the other hydrants will be outside the collapse area of the structure when possible. Hydrants at 300 feet center to center. Blue ground reflector for all hydrants for the project as soon as they are put in service. ( Replaced if second lift of road surface is done later )

Public hydrants need to be installed if the water lines are updated around the project, Hydrants need to be installed per Oregon Fire Code Appendix C Table C105.1

Fully fire sprinklered including overhangs. Dust collection system duct work will be protected with fire sprinkler heads to ensure suppression per Oregon Fire Code Chapter 22.

Fire department connection (FDC) within 50 feet of a hydrant dedicated to the FDC, with address number on the FDC pipe, FDC pipe painted red, BRASSB male plug for caps instead of plastic or pot metal caps for better security for the FDC head.. FDC sign 12 x 18 also on the pipe.

Landscaping should be low growing vegetation to not block visibility of the Hydrant, FDC, or addressing.

PDF of approved prints for our Pre-Fire Plan program.

Building will be fully Fire Sprinklered including overhangs.

Fire sprinkler riser room door will be labeled with 8 inch label. "Fire Sprinkler Riser Room "Alarm Panel"

Fire sprinkler dry systems will trip test showing water under 60 seconds for acceptance.

Fire Lanes painted red on curb with – No Parking Fire Lane in white - and signage per Oregon Fire Code

Fire Extinguishers will have 3-d signage mounted for easy visibility.

C of O will be signed off by Canby Fire after a complete walk through and review for compliance.

Underground needs to be flushed, Fire Sprinkler risers flushed, hydrants flushed and flow test.



SE Hazeldell Way and S Walnut Road and is currently used for agricultural purposes. It can be seen in Figure 3.

### Baker Plaza Project

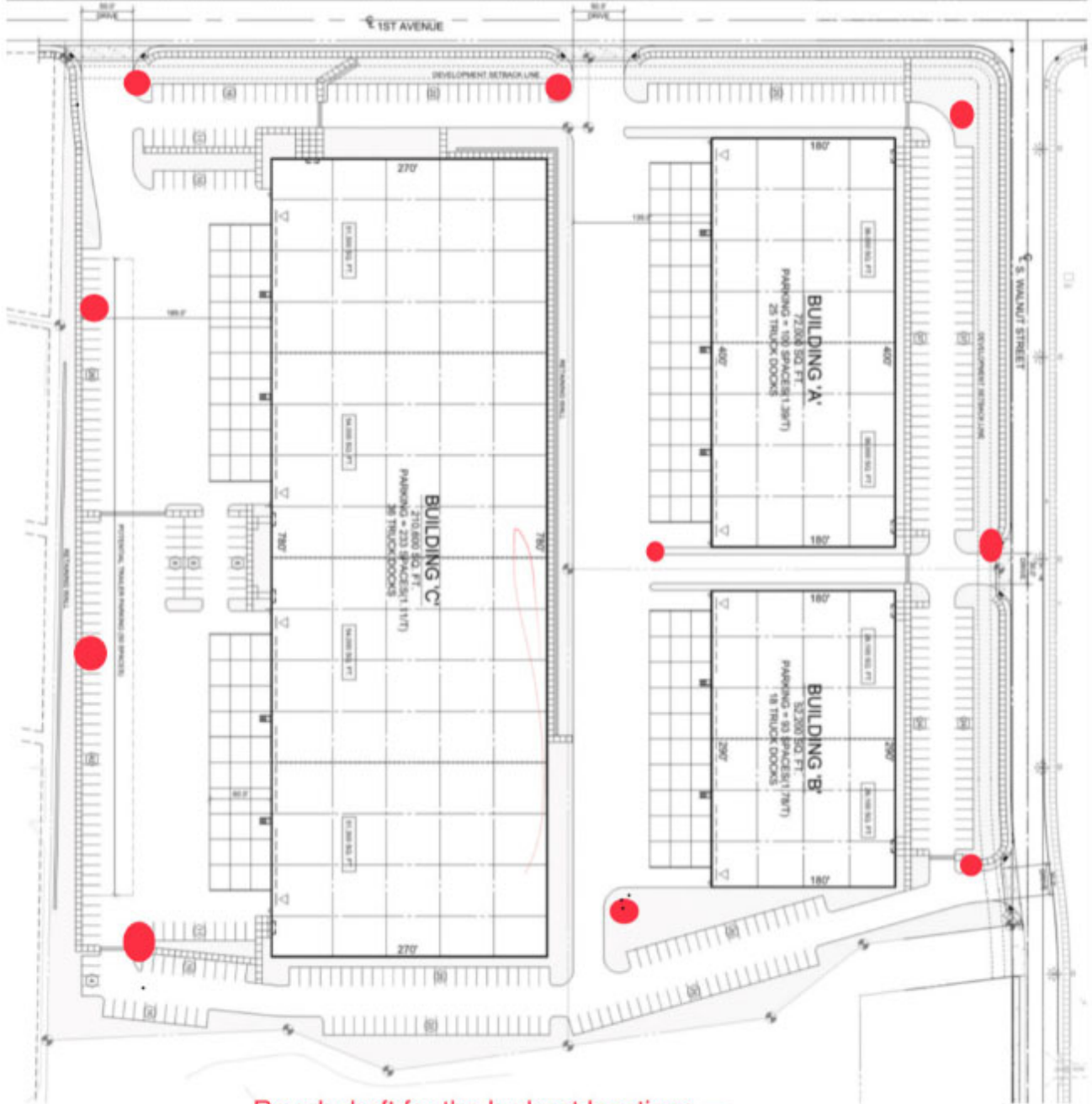

Rough draft for the hydrant locations —

**FIGURE 3: SITE PLAN**

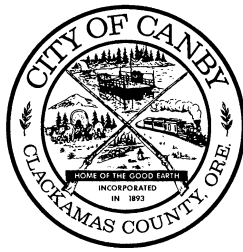

**BEFORE THE PLANNING COMMISSION  
OF THE CITY OF CANBY**

<b>A REQUEST FOR SITE AND DESIGN</b>	)	<b>FINDINGS, CONCLUSION &amp; FINAL ORDER</b>
<b>REVIEW FOR A SPECULATIVE</b>	)	<b>DR 20-02 &amp; PAR 20-02</b>
<b>LIGHT INDUSTRIAL DEVELOPMENT</b>	)	<b>BAKER CENTER</b>
<b>AND RELATED LAND PARTITION AT THE</b>	)	<b>(FORMALLY CANBY WEST)</b>
<b>SW CORNER OF SE 1ST AVENUE</b>	)	
<b>AND S WALNUT STREET</b>	)	

**NATURE OF THE APPLICATION**

The Applicant has sought approval to partition a 20.2-acre property into three parcels (**City File PAR 20-02**) and construct three speculative light industrial buildings ranging from 46,800 to 210,600 square feet (**City File DR 20-02**). Each building would be located on its own parcel but the development would share a vehicular circulation system that connects the buildings' respective parking areas.

The project site is located at the corner of SE 1<sup>st</sup> Avenue and S Walnut Street in the Canby Pioneer Industrial Park. SE Hazel Dell Way is located to the west but is not directly adjacent to the subject property. The subject property is currently used for agricultural purposes; is devoid of buildings or structures; and is largely flat. It is zoned M-1, Light Industrial; is within the Canby Industrial Park Area Overlay (I-O) zone; and is designated for Light Industrial (LI) uses in the City of Canby Comprehensive Plan.

**HEARINGS**

The Planning Commission considered applications **DR 19-02 and PAR 20-02** after the duly noticed hearing on August 10, 2020 during which the Planning Commission approved by a   /   vote **Baker Center (City Files DR 20-02 and PAR 20-02)**. These Findings are entered to document the approval.

**CRITERIA AND STANDARDS**

In judging whether or not the aforementioned application shall be approved, the Planning Commission determines whether criteria from the City of Canby Land Development and Planning Ordinance are met, or can be met by observance of conditions. Applicable code criteria and standards were reviewed in the Staff Report dated July 31, 2020 and presented at the August 10, 2020 meeting of the Canby Planning Commission.



## FINDINGS AND REASONS

The Staff Report was presented, and written and oral testimony was received at the public hearing. Staff recommended approval of the Site and Design Review and Partition applications and applied Conditions of Approval in order to ensure that the proposed project will meet all required City of Canby Land Development and Planning Ordinance approval criteria.

## CONCLUSION

In summary, the Planning Commission adopted the findings contained in the Staff Report along with the additional findings concluded at the public hearing and noted herein, concluding that the application met all applicable approval criteria to the extent feasible, and recommending that **Baker Center (City Files DR 20-02 and PAR 20-02)** be approved with the Conditions of Approval reflected in the written Order below.

## ORDER

The Planning Commission concludes that, with the following conditions, the application meets the requirements for Site and Design Review and Partition approval. Therefore, IT IS ORDERED BY THE PLANNING COMMISSION of the City of Canby that **Baker Center (City Files DR 20-02 and PAR 20-02)** is approved, subject to the following conditions:

## CONDITIONS OF APPROVAL

### **Street and Utility Improvements:**

1. Public improvements shall comply with all applicable City of Canby Public Works Design Standards. Identified street improvements and right-of-way dedications must be designed and constructed (or bonded) to the satisfaction of the City Engineer.
2. The street classification of this roadway has been updated from a Local Street to an Industrial Collector Street; the existing right-of-way is 40 feet, or 20 feet on each side of the centerline. The applicant shall dedicate an additional 17 feet of right-of-way on SE 1st Avenue to accommodate buildout of a street section consistent with an Industrial Collector street classification. Half-street improvements shall be required along the entire site frontage of SE 1st Avenue where the curb line is placed at 25 feet from the right-of-way centerline. Improvements shall include 5-foot planter strips and 6-foot-wide concrete sidewalks, street lights, and street trees. The applicant shall identify a 12-foot-wide public utility easement (PUE) abutting the new right-of-way dedication on SE 1st Avenue.
3. The minimum centerline horizontal radius for collector streets shall be 270 feet.
4. The sanitary sewer in SE 1st Avenue shall be extended from Hazel Dell Way to the intersection with S Walnut Street. The location of the manhole shall not conflict with the turnabout configuration while the depth of the manhole at S Walnut Street needs to be a minimum of 14 feet to accommodate serving the properties on both sides of the future S Walnut Street extension to Highway 99E.
5. A public 8-inch sewer line shall be extended along the westerly property line of the project site and extended to the southerly property line, terminating with a minimum of an 8-foot deep manhole to serve the remaining undeveloped properties to the south.
6. Right-of-way dedication shall be required at the intersection of SE 1st Avenue and S Walnut Street to accommodate the future turnabout as part of a planned extension of S Walnut

Street to Highway 99E. Prior to approval of construction documents for public improvements related to the proposed project, the project design shall be modified to reflect the design of the future turnabout as shown in construction drawings provided to the project applicant by the City Engineer.

7. Consistent with the City of Canby Industrial Area Master Plan prepared by OTAK Engineering, date October 1998, and the City Transportation System Plan (TSP), half-street improvements to S Walnut along the project site's eastern frontage shall be constructed to a local street standard as per the Public Works Design Standards. Half-street improvements shall be constructed along the entire site frontage from the south terminus half-street improvements to SE 1st Avenue to match the ultimate existing paved street width of 32 feet to include a planter strip and 6-foot-wide concrete sidewalk. A 12-foot public utility easement (PUE) shall be provided.
8. Access driveways along Walnut Street shall be industrial type with large-radius curb returns to account for truck traffic.
9. Driveways widths shall be a maximum of 40-feet wide as per City of Canby Municipal Code unless specifically allowed by the City Engineer.
10. All driveways shall have an industrial driveway approach consisting of 8-inch minimum concrete thickness with reinforcements or mesh welded wire fabric.
11. The curb return radii at intersections and driveways shall be large enough to allow for AASHTO WB-67 vehicle turning movements. The property line shall be concentric with this return. The applicant's engineer shall submit to the City truck turning movement templates demonstrating that the turning movement requirements are met.
12. All private storm drainage shall be disposed onsite. The design methodology shall be in conformance with the City of Canby December 2019 Public Works Standards.
13. The applicant shall demonstrate how the storm runoff generated from the new impervious surfaces will be disposed. If drywells (UIC) are used as a means to discharge storm runoff from private streets, they must meet the following criteria:
  - a. The UIC structures' location shall meet at least of the two conditions:
    - i. The vertical separation distance between the UIC and seasonal high groundwater is more than 2.5 feet, or
    - ii. The horizontal separation distance between the UIC and nay water well is a minimum of 267 feet in accordance with the City of Canby Stormwater Master Plan, Appendix "C", Groundwater Protectiveness Demonstration and Risk Prioritization for Underground Injection Control Devices.

The storm water drainage report shall be in conformance with the requirements as stated in Chapter 4 of the City of Canby Public Works Design Standards dated December 2019.

14. Any existing domestic or irrigation wells shall be abandoned in conformance with OAR 690-220-0030. A copy of an Oregon Water Rights Department (OWRD) abandonment certificate shall be submitted to the City.
15. Any existing onsite sewage disposal system shall be abandoned in conformance with DEQ and Clackamas County Water Environmental Services (WES) regulations. A copy of the septic tank removal certificate shall be submitted to the City.
16. Water services and fire protection shall be constructed in conformance with Canby Utility and Canby Fire Department requirements.

17. The project applicant shall coordinate with CFD to identify appropriate locations for fire hydrants. Prior to site plan approval, the project applicant shall provide an updated site plan identifying hydrant locations to the satisfaction of CFD.

**Site Access:**

18. Circulation of truck traffic to or from the project site via S Haines Road shall be generally limited to extraordinary or emergency use. The future property owners of the three proposed parcels shall distribute information to their tenants on a regular basis identifying a requirement that truck trips generated by the project site use SE 1st Avenue/SE Hazel Dell Way and S Walnut Street to access Sequoia Parkway until either: (1) the alternative industrial access road to Highway 99E from S Walnut Street is completed, or (2) S Haines Road has been brought up to a collector street standard up to Highway 99E.

**Partition/Final Plat and Survey Accuracy:**

19. The partition plat shall reflect additional right-of-way dedication required to accommodate a future turnabout at the intersection of SE 1st Avenue and S Walnut Street. This right-of-way dedication shall be consistent with the construction drawings provided to the project applicant by the City Engineer.
20. All public improvements are typically installed prior to the recordation of the final plat. If the applicant wishes to forgo construction of any portion of the public improvements until after the recordation of the final plat, then the applicant shall provide the City with appropriate performance security (subdivision performance bond or cash escrow) in the amount of 110% of the cost of the remaining public improvements to be installed and enter into an agreement outlining the timing of the bonded improvements.
21. The applicant shall apply for final plat approval at the City and pay any applicable City fees to gain approval of the final partition plat. Prior to the recordation of the final plat at Clackamas County, it must be approved by the City and all other applicable agencies. The City will distribute the final plat to applicable agencies for comment prior to signing off on the final plat if deemed necessary.
22. All public improvements or submittal of necessary performance security assurance shall be made prior to the signing and release of the final plat for filing of record.
23. The final plat shall conform to the necessary information requirements of CMC 16.68.030, 16.68.040(B), and 16.68.050. The City Engineer or County Surveyor shall verify that these standards are met prior to the recordation of the plat.
24. The applicant shall work with Canby Utility and Canby Public Works Department in order to provide the appropriate connections to all required utilities as well as demonstrate final utility easement placement, prior to final map recordation.
25. Clackamas County Surveying reviews pending partition plat documents for Oregon Statutes and County requirements. A final plat prepared in substantial conformance with the approved tentative plat must be submitted to the City for approval within one year of approval of the tentative plat or formally request an extension of up to 6-months with a finding of good cause.
26. The project applicant shall record the final plat at Clackamas County within 6 months of the date of the signature of the Planning Director.
27. The applicant shall assure that the City is provided with a copy of the final plat in a timely manner after it is recorded at Clackamas County, including any CC&Rs, if applicable, recorded in conjunction with the final plat.

28. The placement of utility easements, including 12-foot-wide public utility easements along SE 1st Avenue and S Walnut Street, shall be noted on the final plat. Utility easements may be combined with other easements and shall be measured from the property boundary.
29. The County Surveyor shall verify that the survey accuracy and monumentation requirements set forth in Oregon Revised Statutes and CMC 16.64.070(M) are met prior to the recordation of the final plat. Installation of the front lot monumentation (along and within street rights-of-way) and the replacement of any existing monuments destroyed during improvement installation shall be confirmed by the City Engineer or County Surveyor prior to the recordation of the final partition plat.
30. Monuments shall be reestablished and protected in monument boxes at every street intersection and all points of curvature and points of tangency of street centerlines as required by Oregon Revised Statutes Chapter 92. The City Engineer or County Surveyor shall verify compliance with this condition prior to the recordation of the final plat.

**Project Design/Site Plan Approval:**

31. Consistent with Subsection 16.10.100, Bicycle Parking, of the Municipal Code, the proposed project shall be modified to provide bicycle parking within 50 feet of the main entrance of each building. Prior to site plan approval, the project applicant shall submit a final site plan demonstrating that the location and design of proposed bicycle parking conforms to the aforementioned code section.
32. Consistent with Subsection 16.49.120, Parking Lot Landscaping Standards, the proposed surface parking shall be redesigned to “break up the parking area into rows of not more than 8 contiguous spaces.” Prior to site plan approval, the applicant shall submit to the City a revised site plan demonstrating compliance with this condition, along with revised landscaping calculations reflecting the change in site design/lot coverage.
33. Prior to site plan approval, a lighting plan shall be submitted to the City consistent with Chapter 16.43, Outdoor Lighting Standards, of the Municipal Code. This shall include an exhibit(s) demonstrating that the proposed light fixtures would be shielded and that light generated would not exceed the maximum lumens identified in Table 16.43.070 of the Canby Municipal Code.
34. Prior to site plan approval, the project applicant shall provide Canby Public Works with construction drawings compliant with the Canby Municipal Code and Canby Public Works Standards, to the satisfaction of the City Engineer.

**Building Permits:**

35. Prior to the pre-construction meeting and issuance of grading permits, the applicant shall comply with all applicable Canby Fire District (CFD) requirements as identified in the memo received from CFD and attached to this Staff Report. Please contact the CFD Division Chief at 503-266-5851 for further information.
36. The project applicant shall secure a Street Opening and/or Driveway Construction permit for all paved driveway or utility installations associated with the proposed development or offsite improvements. Said permits shall comply with the City’s Public Works Design Standards.
37. The design engineer shall submit to the City of Canby for review and approval at the time of final construction plan approval a storm drainage analysis and report applicable to the defined development area detailing how storm water disposal from both the building and the parking areas is being handled. Any drainage plan shall conform to an acceptable

methodology for meeting adopted storm drainage design standards as indicated in the Public Works design standards.

38. Construction plans shall be designed and stamped by a Professional Engineer registered in the State of Oregon.
39. Prior to occupancy, sight distance at all access points will need to be verified, documented, and stamped by a registered professional Civil or Traffic Engineer licensed in the State of Oregon.
40. The project applicant shall apply for a City of Canby Site Plan Permit, Clackamas County Building permits, and a City of Canby Erosion Control Permit from the Canby Public Works Department.
41. Clackamas County Building Codes Division will provide structural, electrical, plumbing, and mechanical plan review and inspection services for construction of the project.
42. The applicant shall file a sign permit for any future signs that shall be limited to the size and height standards applicable to the I-O (Canby Industrial Area Overlay Zone) as indicated in Section 16.42.050, Table 7, of the sign ordinance. Proposed signs, after been found to conform to the sign ordinance, must secure a building permit from Clackamas County Building Inspection prior to their installation.

**During Construction:**

43. If a gravesite is discovered during earthmoving or construction activities, the applicant or contractor shall notify the City and Zoar Lutheran Church prior to further disturbance of the discovery. The applicant and contractors shall comply with all applicable state and federal regulations pertaining to discovery and treatment (e.g., removal or preservation-in-place) of human remains.

**Prior to Occupancy:**

44. Prior to occupancy of the facility, all landscaping plant material indicated on the submitted landscape plan shall either be installed and irrigated as proposed, or sufficient security (bonding, escrow, etc.) shall be provided pursuant to the provisions of CMC 16.49.100 (B). The applicant should be aware that the City street tree fee is now \$250 per tree if planted by the City, and the City recommends submittal of a separate Street Tree Plan to assist in the location, species, and total tree count.