

**ORDINANCE NO. 1504**

**AN ORDINANCE AUTHORIZING THE MAYOR AND CITY ADMINISTRATOR TO EXECUTE A CONTRACT WITH EAGLE-ELSNER, INC. IN THE AMOUNT OF \$522,949.50 FOR N MAPLE STREET IMPROVEMENTS; AND DECLARING AN EMERGENCY.**

**WHEREAS**, the City of Canby has heretofore advertised and received eight (8) bids for the N Maple Street Improvements project; and

**WHEREAS**, the notice of call for bids was duly and regularly published in the Oregon Daily Journal of Commerce on January 28, 2019; and

**WHEREAS**, bids were received and opened on February 19, 2019 at 2:00 pm in the City Hall Conference Room of the City of Canby and the bids were read aloud; and

**WHEREAS**, the bidders are as listed below, and a detailed tabulation of all items is attached herein and summarized as follows:

1.	Eagle-Elsner, Inc.	\$522,949.50
2.	Canby Excavating, Inc.	\$530,530.25
3.	M.L. Houck Construction, Co.	\$570,765.00
4.	North Santiam Paving, Co.	\$584,002.00
5.	Kerr Contractors Oregon, Inc.	\$598,856.50
6.	Elting Northwest, Inc.	\$630,344.00
7.	D&D Concrete & Utilities	\$673,835.00
8.	Northcore USA, LLC	\$697,710.51

**WHEREAS**, the Canby City Council, acting as the City's Contract Review Board, met on Wednesday, March 6, 2019, and considered the bids and reports and recommendations of the City staff, including the staff recommendation that the low responsive bid be selected; and

**WHEREAS**, the Canby City Council determined that the low responsive bid was that of Eagle-Elsner, Inc.

**NOW, THEREFORE, THE CITY OF CANBY ORDAINS AS FOLLOWS:**

Section 1. The Mayor and/or City Administrator are hereby authorized and directed to make, execute, and declare in the name of the City of Canby and on its behalf, an appropriate contract with Canby Excavating, Inc. for N Maple Street Improvements, in the amount of \$522,949.50. A copy of the Contract for Construction with Eagle-Elsner, Inc. is attached hereto and by this reference incorporated herein.

Section 2. Inasmuch as it is in the best interest of the citizens of Canby, Oregon, to complete this project as soon as possible, an emergency is hereby declared to exist, and this ordinance shall therefore take effect immediately upon its enactment after final reading.

**SUBMITTED** to the Canby City Council and read the first time at a regular meeting therefore on Wednesday, March 6, 2019; ordered posted as required by the Canby City Charter and scheduled for second reading on Wednesday, March 20, 2019, after the hour of 7:00 PM at the Council Meeting Chambers located at 222 NE 2<sup>nd</sup> Avenue, 1<sup>ST</sup> Floor, Canby, Oregon.

  
\_\_\_\_\_  
Kimberly Scheafer, MMC  
City Recorder

**PASSED** on second and final reading by the Canby City Council at a regular meeting thereof on the 20<sup>th</sup> day of March, 2019, by the following vote:

YEAS 5

NAYS 0

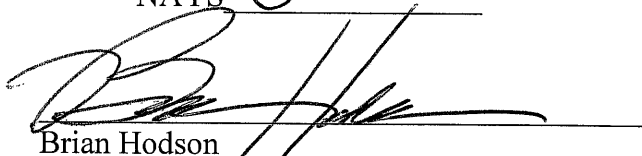
  
\_\_\_\_\_  
Brian Hodson  
Mayor

ATTEST:

  
\_\_\_\_\_  
Kimberly Scheafer, MMC  
City Recorder

Contract Documents, General Conditions, & Technical Specifications

---

# CITY OF CANBY

## N. MAPLE STREET IMPROVEMENTS

Clackamas County, Oregon

February, 2019

CURRAN-McLEOD, INC., Consulting Engineers  
6655 SW Hampton Street, Suite 210  
Portland, OR 97223



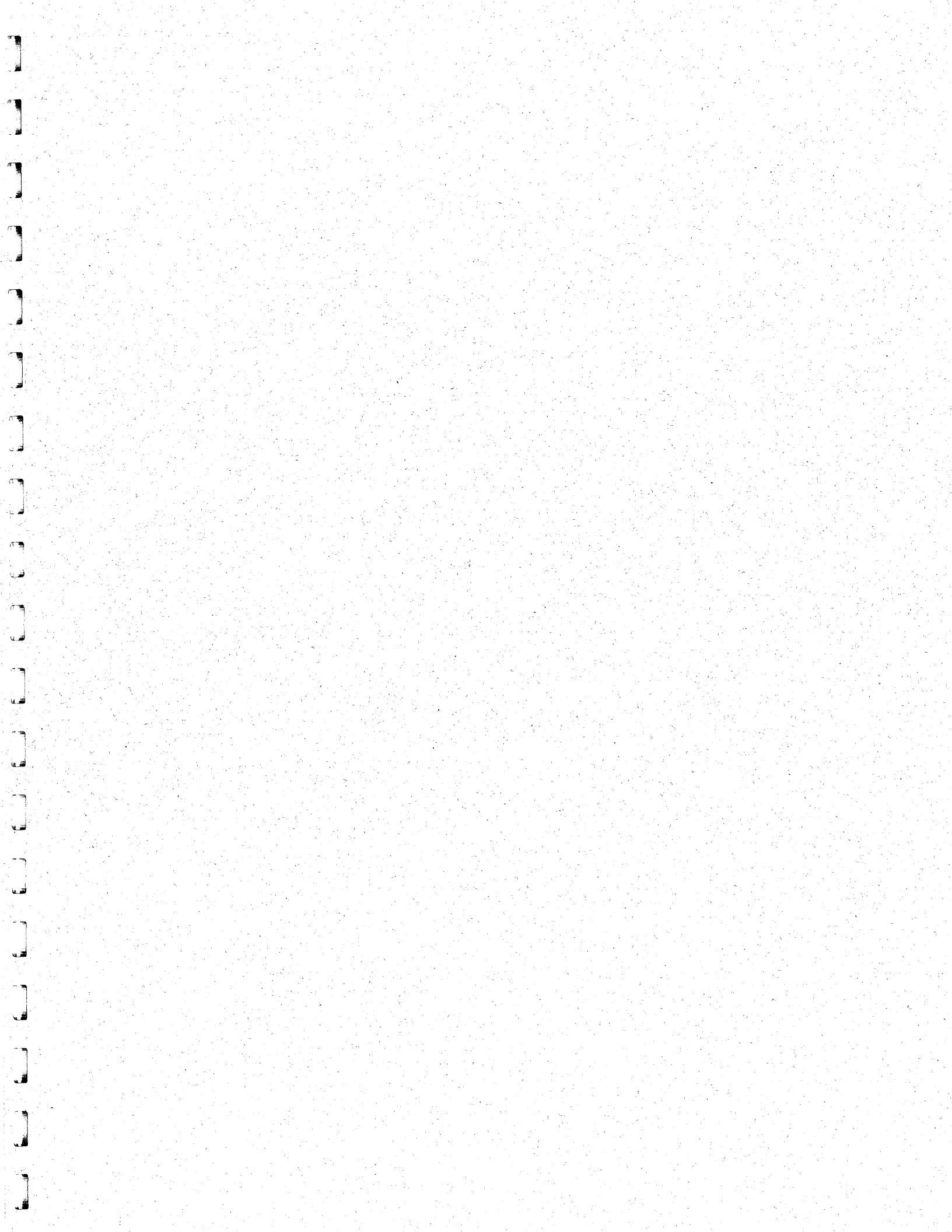



CITY OF CANBY  
N MAPLE STREET IMPROVEMENTS

CURRAN-McLEOD, INC.  
CONSULTING ENGINEERS

Addendum No. 1

Page 1 of 1

February 12, 2019

\*\*\*\*\*

No. ITEM

CHANGE OR CLARIFICATION

\*\*\*\*\*

1. Bid Proposal  
**ALL BIDDERS SHALL USE THE ATTACHED REVISED BID PROPOSAL (pages 13 through 17) IN PLACE OF THE BOUND BID PROPOSAL IN THE CONTRACT DOCUMENTS BOOK.**
  
2. Basic Bid Schedule,  
Page 14, Item A-8  
**CLARIFICATION:** Two (2) W16-7P (24"x12") signs (diagonal downward pointing arrow) will be added and paid for at the bid unit price of item A-8.
  
3. Construction Plans, Sheet C3  
**CLARIFICATION:** The two (2) pedestrian signs W11-2 shown on the plans 30 feet ahead on the crossing will be moved to the location of the crossing and supplemented by the additional two (2) W16-7P signs and attached on the same post.
  
4. Construction Plans, Sheet C3  
**REVISE:** Construction Note 27 to say: "Ramp end of sidewalk to match the existing pavement".
  
5. Construction Plans, Sheets C3 thru C5  
**DELETE:** The note in the box stating: "apply 2" thick AC overlay on existing pavement".
  
6. Technical Specifications, Section 01000, General Requirements, 1.03 B Construction Layout  
**CHANGE:** The first sentence, replace the second word "CONTRACTOR" with the word "OWNER". The City will pay all associated costs related to this item.
  
7. Technical Specifications, Section 01600, Measurement and Payment, Page 01600-7, item D-1  
**CHANGE:** The fourth sentence shall read as follows: "The length of the lateral shall be replaced and connected to extent of 5 feet from the new cleanout on the customer side if agreed by the property owner".

Attachments: Revised Bid Proposal Form



**REVISED BID PROPOSAL**

---

**TO:** Mr. Jerry Nelzen  
Public Works Operations Supervisor \_\_\_\_\_, 2019  
City of Canby  
222 NE 2<sup>nd</sup> Avenue  
Canby, OR 97013

The undersigned is a (indicate one):

- RESIDENT     NON RESIDENT

bidder as defined by ORS 279A.120, structured as (check one of the following and insert information requested):

- a. A Corporation organized and existing under laws of the State of \_\_\_\_\_; or
- b. A Partnership registered under the laws of the State of \_\_\_\_\_; or
- c. An individual doing business under an assumed name registered under the laws of the State of \_\_\_\_\_.

The undersigned bidder declares that the only persons or parties interested in this proposal are those named herein, that this proposal is in all respects fair and without fraud and that it is made without collusion with any representatives of the OWNER.

The bidder further declares that: a) he has examined the plans, specifications, and other proposed contract documents; b) he has determined the extent, character, and location of the proposed Work, the nature and type of excavation to be done, the location and condition of existing streets and roadways giving access to the site of the Work, and topography of the site of the Work; and c) he has personally inspected the site of the Work and has satisfied himself as to the conditions of the Work and understands the listing of materials as included herein is brief and is intended only to associate the said quantities with detailed requirements of the contract documents.

The bidder does hereby propose to furnish all materials, tools, equipment, and appliances, and to perform all labor and work necessary to construct and complete the project entitled:

**City of Canby**  
**N Maple Street Improvements**

and all specified work appurtenant thereto, and in connection with this project for the OWNER with the time limit specified, and in accordance with plans, specifications and change order documents prepared by the ENGINEER for the sums set forth in the following schedule of prices, it being understood that the unit prices are independent of the exact quantities involved and that they represent a true measure of the labor and materials required to perform the Work.

The successful bidder agrees that if this proposal is accepted, bidder will execute the required documents and supply the required submittal information as specified herein, within the time frames established herein.

The successful bidder agrees to be substantially complete with all work within 60 days of the Notice to Proceed, and achieve final completion within 15 calendar days after issuance of the Certificate of Substantial Completion including punch list items.

In the event the successful bidder fails to achieve Substantial Completion or Final Completion of the project within the time limits specified or extended time limits as agreed upon, liquidated damages shall be paid to the OWNER or deducted from amounts due the Contractor, at the rate of Four Hundred Dollars (\$400.00) per calendar day until Substantial Completion is achieved, and/or until Final Completion is achieved. Sundays and legal holidays shall be excluded in determining the number of days in default.

The project will be awarded based on the low responsive bid for all the work listed in the basic bid schedule below.

**BASIC BID SCHEDULE - N Maple Street Improvements:**

Item No.	Description	Quantity	Unit	Unit Price	Total
<b>A. Site Preparation &amp; Restoration</b>					
A-1	Mobilization, Bond & Insurance	All	Lump Sum		
A-2	Temporary Protection & Direction of Traffic, Temporary Signing	All	LS		
A-3	Erosion Control & Spill Prevention Control & Countermeasure (SPCC) Plans	All	LS		
A-4	Clearing & Grubbing, Tree Removal & Landscape Protection, Site Restoration	All	LS		
A-5	Common Excavation	1,850	CY		
A-6	Subgrade/ Trench Stabilization	50	CY		
A-7	Sawcut Asphalt/ Concrete Pavement (All Depth)	350	LF		
A-8	Install four (4) Traffic Signs on two (2) Posts	4	Each		
A-9	Remove, Salvage and Reinstall Existing Mail / Newspaper Boxes on New Post With New V-Loc Base (Multiple)	5	Each		
A-10	Remove, Salvage and Reinstall Existing Mail / Newspaper Box on New Post With New V-Loc Base (Single)	3	Each		
A-11	Remove, Salvage & Relocate Existing Decorative Mail Box to New Sidewalk	2	Each		
A-12	Continental Cross Bars & Stop Bars	150	SF		
Subtotal					
<b>B. Paving &amp; Surfacing</b>					
B-1	1"-0" Crushed Rock Base (12" deep)	4,425	SY		
B-2	Standard Concrete Curb & Gutter including Excavation and 6" Leveling Rock	2,335	LF		
B-3	Short Concrete Curb at back of ADA Ramps	64	LF		
B-4	6" Concrete Residential Driveway including Excavation and 4" Leveling Rock	300	SY		
B-5	4" Concrete Sidewalk or Driveway including Excavation and 2" Leveling Rock	1,100	SY		



B-6	Detectable Warning Tile (ADA Ramp)	4	Each		
B-7	Asphalt Driveway Restoration including Excavation and 8" Leveling Rock	100	SY		
B-8	Gravel Driveway Restoration including Excavation and 4" Leveling Rock	40	SY		
B-9	½" Dense Mix AC Pavement, Level II	1,100	Tons		
B-10	Precast Concrete Manorstone Block Retaining Wall (Gray Color Units)	250	SF		
B-11	Minor Exist Manhole/Cleanout Adjustment to Grade	6	Each		
Subtotal					
<b>C. Storm Drain Improvements</b>					
C-1	10" PVC C900 Pipe including Trench Excavation & Material Disposal and Compacted Crushed Rock Backfill	9	LF		
C-1A	10" PVC 3034 Pipe including Trench Excavation & Material Disposal and Compacted Crushed Rock Backfill	26	LF		
C-2	Remove Exist Catch Basin & Cap End of Pipe	2	Each		
C-3	Type G-2 Catch Basin	2	Each		
C-4	Waite Catch Basin	2	Each		
C-5	New Drywell	1	Each		
C-6	Connect to Exist Drywell	1	Each		
Subtotal					
<b>D. Sanitary Sewer</b>					
D-1	6" Cleanout Assembly over Exist 6" Concrete Pipe Including Trench Excavation & Material Disposal and Crushed Rock Backfill	22	Each		
D-2	New 6" PVC 3034 Sewer Lateral with 6" Cleanout including Trench Excavation & Material Disposal and Compacted Crushed Rock Backfill (long run)	3	Each		
D-3	New 6" PVC 3034 Sewer Lateral with 6" Cleanout including Trench Excavation & Material Disposal and Compacted Crushed Rock Backfill (short run)	1	Each		
Subtotal					
<b>E. Waterlines</b>					
E-1	Remove & Salvage Exist Fire Hydrant including Removal of Spool and installing Blind Flange at Exist Valve, Trench Excavation & Material Disposal and Compacted Crushed Rock Backfill	1	Each		
E-2	Relocate Exist Fire Hydrant including 12"x6" Hot Tap, 6" Valve, 6" DI Spool Trench Excavation & Material Disposal and Compacted Crushed Rock Backfill	1	Each		
E-3	New 1" PET Water Service including Trench Excavation & Material Disposal and Compacted Crushed Rock Backfill (long run)	3	Each		

E-4	New 1" PET Water Service including Trench Excavation & Material Disposal and Compacted Crushed Rock Backfill (short run)	1	Each		
E-4	New 1 1/2" PET Water Service including Trench Excavation & Material Disposal and Compacted Crushed Rock Backfill	1	Each		
					Subtotal
<b>F. Utility Construction</b>					
F-1	Excavate and Backfill For Street Light Poles and Backfill with Compacted Crushed Rock	9	Each		
					Subtotal
					<b>TOTAL BASIC BID SCHEDULE</b>

**TOTAL BASIC BID SCHEDULE: \$** \_\_\_\_\_

Accompanying herewith is Bid Security which is equal to five percent (5%) of the total amount of the Basic Bid.

The undersigned agrees, if awarded the Contract, to execute and deliver to the OWNER within fifteen (15) days after receiving the Contract forms, an Agreement and satisfactory Construction Performance and Construction Payment Bonds each in an amount equal to one hundred percent (100%) of the Contract sum, using forms provided therefor by the OWNER. The Surety requested to issue the Construction Performance Bond will be:

\_\_\_\_\_  
(Name of Surety Company)

\_\_\_\_\_  
(Agent Name & Phone Number)

The undersigned hereby authorizes said Surety to disclose any information to the OWNER concerning the undersigned's ability to supply a Construction Performance Bond in the amount of the Contract.

The undersigned certifies that (1) this Bid has been arrived at independently and is being submitted without collusion with, and without any agreement, understanding, or planned common course of action with, any other vendor of materials, supplies, equipment, or services described in the Advertisement for Bids designed to limit independent bidding or competition, (2) the contents of this Bid have not been communicated by the undersigned or its employees or agents to any person not an employee or agent of the undersigned or its surety on any bond furnished with the Bid and will not be communicated to such person prior to the official opening of the bids, and (3) if awarded the Contract, he will commence work within ten (10) calendar days after the date of Notice to Proceed and that he will complete the Work within the specified number of days set forth in the Agreement.

The undersigned certifies that he has received and duly considered the following Addenda to the specifications.

Addenda: No. \_\_\_\_\_ to No. \_\_\_\_\_ inclusive.

The undersigned agrees if awarded the Contract, that he will comply with the provisions of the Contract Documents and will comply with the provisions of ORS 279C.800 and Oregon Prevailing Wage Rates.

Name of Firm \_\_\_\_\_

Signature \_\_\_\_\_

Name \_\_\_\_\_

Address \_\_\_\_\_

Telephone No. \_\_\_\_\_

Construction Contractors Board No. # \_\_\_\_\_

If Corporation,

Attest: \_\_\_\_\_

Secretary of Corporation

\_\_\_\_\_  
\*If bid is by a partnership, then one of the partners must sign the bid.

*This Page Intentionally Left Blank*



**CONTRACT DOCUMENTS, GENERAL CONDITIONS  
AND TECHNICAL SPECIFICATIONS**

# **City of Canby**

## **N MAPLE STREET IMPROVEMENTS**

**Clackamas County, Oregon**

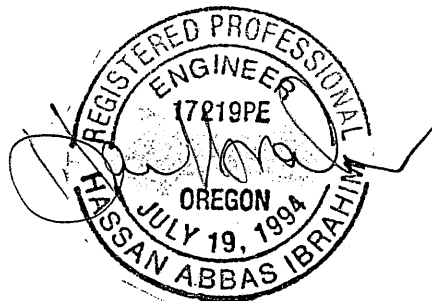

*Copies 6.30.2019*

**February 2019**

**CURRAN-McLEOD, INC. CONSULTING ENGINEERS**  
6655 S.W. Hampton Street, Suite 210  
Portland, Oregon 97223

**City of Canby**  
**N Maple Street Improvements**

**TABLE OF CONTENTS**

	<u>PAGE</u>
Notice to Contractors .....	1
Instructions to Bidders .....	3
Bid Proposal .....	13
Bid Bond .....	19
First-Tier Subcontractor Disclosure Form .....	21
Contract for Construction .....	23
Construction Performance Bond .....	29
Construction Payment Bond .....	33
General Conditions of the Construction Contract .....	37
Supplementary General Conditions .....	73
Prevailing Wage Rate Determination .....	79

***TECHNICAL SPECIFICATIONS***

**DIVISION 1 – GENERAL REQUIREMENTS**

- 01000      General Requirements
- 01500      Contractor Facilities and Temporary Controls
- 01600      Measurement and Payment
- 01700      Project Closeout

**DIVISION 2 – SITE WORK**

- 02100      Site Preparation
- 02200      Earthwork
- 02500      Paving and Surfacing
- 02700      Site Piping
- 02900      Landscaping

**ATTACHMENTS**

- Construction Plans (Sheets C1 thru C9 )

*This Page Intentionally Left Blank*

**NOTICE TO CONTRACTORS**

**NOTICE TO CONTRACTORS**

## NOTICE TO CONTRACTORS

---

Sealed bids for *N Maple Street Improvements* will be received by the City Public Works Operations Supervisor of the City of Canby until 2:00 P.M on Tuesday, February 19, 2019 at which time bidding will be closed.

Pursuant to ORS 279C.370(2), within two (2) working hours of the Bid Closing, all Bidders shall submit to the City a disclosure form as furnished with these bid documents identifying any first-tier subcontractors (those Entities that would be contracting directly with the prime contractor) that will be furnishing labor or materials on the Contract, if awarded, whose subcontract value would be equal to or greater than:

- ♦ Five percent of the total Contract Price, but at least \$15,000, or
- ♦ \$350,000 regardless of the percentage of the total Contract Price.

Bids and disclosure forms shall be addressed to Mr. Jerry Nelzen, Public Works Operations Supervisor, City of Canby, 222 NE 2<sup>nd</sup> Ave, Canby, Oregon 97013. At 2:00 P.M., bids will be opened and read aloud in the City Hall Conference Room, Canby, Oregon. Only bids for which a disclosure form has been submitted within two (2) working hours of the Bid Closing date and time will be considered responsive.

The scope of work generally consists of the following:

- Construction of approximately 1,300 lineal feet of street full street reconstruction to include excavation, new curbs and gutter, concrete sidewalks and driveways, installation of cleanouts over (22) existing 6" sanitary sewer laterals, add four (4) new sanitary sewer and water services, storm drainage to include one (1) new drywell and 4 catch basins, base coarse, pavement and site restoration.

The estimated construction cost on this project is \$500,000.

Specifications are available at the offices of CURRAN-McLEOD, INC., Consulting Engineers, 6655 S.W. Hampton Street, Suite 210, Portland, Oregon, 97223, telephone: (503) 684-3478. All questions related to the project shall be directed to Hassan Ibrahim of CURRAN-McLEOD, INC., Consulting Engineers. Electronic .PDF copies are available without charge for contractors and material suppliers upon registration with the Engineer. (Please email [cmi@curran-mcleod.com](mailto:cmi@curran-mcleod.com) to register and request an electronic copy). A forty- dollar (\$40.00) non-refundable fee is required with each request for hard copies. Specifications may be examined at the following locations:

City of Canby	222 NE 2 <sup>nd</sup> Avenue	Canby, OR
Central Oregon Builders Exchange	1902 NE 4 <sup>th</sup>	Bend, OR
Daily Journal of Commerce – OR	Electronic Only - (503) 274-0624	Portland, OR
Eugene Builders Exchange	2460 West 11 <sup>th</sup>	Eugene, OR
McGraw-Hill Construction/Dodge	3461 NW Yeon Ave	Portland, OR
Oregon Contractor Plan Center	5468 SE International Way	Clackamas, OR
Salem Contractors Exchange	2256 Judson St. S.E.	Salem, OR
SW Washington Contractors Assoc.	7017 N.E. Hwy 99, #214	Vancouver, WA
Willamette Valley Bid Center	33862 SE Eastgate Cr.	Corvallis, OR

Bidders must be pre-qualified to bid on this project. Bidders not currently pre-qualified by the Owner, Engineer or the Oregon Department of Transportation may apply for pre-qualification with the Owner or Engineer prior to the bid opening on forms available or similar to those available from the Oregon Department of Transportation.

No bid shall be received or considered unless the Bidder is registered with the Construction Contractors Board as required by ORS chapter 701.021.

To be considered, bids must be completed on the bidding forms provided, in the manner prescribed in the bidding documents and accompanied by a 5% bid security in favor of the City of Canby. Each bidder must indicate in the space provided on the Bid Form, whether they are a Resident or Non-Resident Bidder pursuant to ORS 279A.120.

This public works project is subject to the provisions of ORS 279C.800 to ORS 279C.870. By submission of a bid, each bidder certifies that Oregon Prevailing Wage Rates are included in the bid prices. Contractors need not be licensed for asbestos handling per ORS 468A.720 to complete this project. A pre-bid conference will not be held for this project.

The City of Canby reserves the right to reject any or all bids not in compliance with all prescribed public bidding procedures and requirements, may reject for good cause any and all bids upon a finding of the agency it is in the public interest to do so, and may waive all informalities. No bidder may withdraw or modify his bid prior to the lapse of thirty (30) days after bid opening.

By Order of the City Council of the City of Canby.

Published by the Portland Daily Journal of Commerce, January 28, 2019



**INSTRUCTIONS TO BIDDERS**

**INSTRUCTIONS TO BIDDERS**

## **INSTRUCTIONS TO BIDDERS**

---

### **ARTICLE 1 - DEFINED TERMS**

- 1.1 Terms used in these Instructions to Bidders which are defined in the Standard General Conditions of the Construction Contract (No. C-700, 2013 Ed.) have the meanings assigned to them in the General Conditions. The term "Bidder" means one who submits a Bid directly to OWNER, as distinct from a sub-bidder, who submits a bid to a Bidder. The term "Successful Bidder" means the lowest, qualified, responsible and responsive Bidder to whom OWNER (on the basis of OWNER'S evaluation as hereinafter provided) makes an award. The term "Bidding Documents" includes the Advertisement or Invitation to Bid, Instructions to Bidders, the Bid Form, and the proposed Contract Documents (including all Addenda issued prior to receipt of Bids).

### **ARTICLE 2 - COPIES OF BIDDING DOCUMENTS**

- 2.1 Complete sets of Bidding Documents in the number and for the sum, if any, stated in the Advertisement or Invitation to Bid may be obtained from ENGINEER.
- 2.2 Complete sets of Bidding Documents must be used in preparing Bids. Neither OWNER nor ENGINEER assume any responsibility for errors or misinterpretations resulting from the use of incomplete sets of Bidding Documents.
- 2.3 OWNER and ENGINEER in making copies of Bidding Documents available on the above terms do so only for the purpose of obtaining Bids on the Work and do not confer a license or grant for any other use.

### **ARTICLE 3 - QUALIFICATIONS OF BIDDERS**

- 3.1 Bidders must be pre-qualified to bid on this project. Bidders not currently pre-qualified for this Contract by the OWNER, ENGINEER or the Oregon State Department of Transportation may apply for pre-qualification by filing a completed pre-qualification statement with the ENGINEER on a form prescribed by the Oregon State Department of Transportation. Bidders filing pre-qualification applications with the ENGINEER should file the statement no later than the scheduled date for receipt of Bids.

## ARTICLE 4 - EXAMINATION OF CONTRACT DOCUMENTS AND SITE

- 4.1 It is the responsibility of each Bidder before submitting a Bid, to (a) examine the Contract Documents thoroughly, (b) visit the site to become familiar with local conditions that may affect cost, progress, performance, or furnishing of the Work, (c) consider Federal, State and Local Laws and Regulations that may affect cost, progress, performance or furnishing of the Work, (d) study and carefully correlate Bidder's observations with the Contract Documents, and (e) notify ENGINEER of all conflicts, errors, or discrepancies in the Contract Documents.
- 4.2 Information and data reflected in the Contract Documents with respect to Underground Facilities at or contiguous to the site is based upon information and data furnished to OWNER and ENGINEER by owners of such Underground Facilities or others, and OWNER does not assume responsibility for the accuracy or completeness thereof unless it is expressly provided otherwise in the Supplementary Conditions.
- 4.3 Provisions concerning responsibilities for the adequacy of data furnished to prospective Bidders on subsurface conditions, underground facilities and other physical conditions, and possible changes in the Contract Documents due to differing conditions appear in Article 5 of the General Conditions.
- 4.4 Before submitting a Bid each Bidder will be responsible to make or obtain such explorations, tests, and data concerning physical conditions (surface, subsurface, and Underground Facilities) at or contiguous to the site, or otherwise which may affect cost, progress, performance, or furnishing of the Work and which Bidder deems necessary to determine its Bid for performing and furnishing the Work in accordance with the time, price, and other terms and conditions of the Contract Documents.
- 4.5 On request in advance, OWNER will provide each bidder access to the site to conduct such explorations and tests as Bidder deems necessary for submission of a Bid. Bidder shall fill all holes, clean up, and restore the site to its former condition upon completion of such explorations.
- 4.6 The lands upon which the Work is to be performed, rights-of-way and easements for access thereto and other land designated for use by the Contractor in performing the Work are identified in the Contract Documents. All additional lands and access thereto required for temporary construction facilities or storage of materials and equipment are to be provided by Contractor. Easements for permanent structures or permanent changes in existing structures are to be obtained and paid for by OWNER unless otherwise provided in the Contract Documents.

- 4.7 The submission of a bid will constitute an incontrovertible representation by Bidder that Bidder has complied with every requirement of this ARTICLE 4, that without exception the Bid is premised upon performing and furnishing the Work required by the Contract Documents and such means, methods, techniques, sequences, or procedures of construction as may be indicated in or required by the Contract Documents, and that the Contract Documents are sufficient in scope and detail to indicate and convey understanding of all terms and conditions for performance and furnishing of the Work to complete the project.

## **ARTICLE 5 - INTERPRETATIONS AND ADDENDA**

- 5.1 All questions about the meaning or intent of the Contract Documents are to be directed to the ENGINEER. Interpretations or clarifications considered necessary by the ENGINEER in response to such questions will be issued by Addenda mailed or delivered to all parties recorded by ENGINEER as having received the Bidding Documents. Questions received less than three days prior to the date for the opening of Bids may not be answered. Only questions answered by formal written Addenda will be binding. Oral and other interpretations or clarifications will be without legal effect.
- 5.2 Addenda may also be issued to modify the Bidding Documents as deemed advisable by OWNER or ENGINEER.

## **ARTICLE 6 - BID SECURITY**

- 6.1 Bid Security in the amount of five percent (5%) of the Base Bid must accompany each Bid proposal. Bid Security may be in the form of a surety bond or cashier's check, but if it is a surety bond, it must comply with the requirements of Article 5 of the General Conditions. If a surety bond is submitted as Bid Security, it shall be written on EJCDC NO. C-430, Bid Bond, or similar instrument, and the attorney-in-fact who executes the bond shall affix to the bond a current copy of his power of attorney. Surety companies executing bonds must appear on the U.S. Treasury Department's most current list (Circular 570 as amended) and be authorized to transact business in the state where the project is located.
- 6.2 The Bid security of the top three Bidder will be retained until the successful Bidder has executed the Agreement and furnished the required contract security, whereupon the Bid Securities will be returned. If the Successful Bidder fails to execute and deliver the Agreement and furnish the required contract security within ten (10) days after the Notice of Award, OWNER may annul the Notice of Award and the Bid Security of that Bidder will be forfeited. The Bid Security of other Bidders whom the OWNER believes to have a reasonable chance of receiving the award may be retained by the OWNER until the earlier of the seventh day (7th) day after the Effective Date of the Agreement or the thirty first (31<sup>st</sup>) day after the Bid opening, whereupon Bid Security furnished

by such Bidders will be returned. Bid Security and Bids which are not competitive will be returned within seven (7) days after the Bid opening.

#### **ARTICLE 7 - CONTRACT TIME**

- 7.1 The number of days within which, or the dates by which, the Work is to be substantially completed and also completed and ready for final payment (the Contract Time) are set forth in the Agreement.

#### **ARTICLE 8 - LIQUIDATED DAMAGES**

- 8.1 Provisions for liquidated damages are set forth in the Agreement. Delay damages will be assessed for failure to achieve substantial completion AND/OR final completion as defined in the General Conditions. Liquidated damages shall be paid by the Contractor to the Owner or the OWNER may withhold damages from any amounts due to the Contractor.

#### **ARTICLE 9 - SUBSTITUTING "OR-EQUAL" ITEMS**

- 9.1 The materials and equipment described in the Bidding Documents establish a standard of required function, dimension, appearance, and quality to be met by any proposed substitution. All materials and equipment shall be as specified "or equal", without regard to the presence or lack of "or equal" verbiage in the specific specification unless noted otherwise. No substitution will be considered unless written request for approval has been submitted by the Bidder and has been received by the ENGINEER at least seven (7) days prior to the date for receipt of Bids. Each such request shall include the name of the material or equipment for which it is to be substituted and a complete description of the proposed substitute, including drawings, cuts, performance and test data and any other information necessary for an evaluation. A statement setting forth any changes in other materials, equipment, or Work that incorporation of the substitution would require shall be included. The burden of proof of the merit of the proposed substitution is upon the Bidder. The ENGINEER'S decision of approval or disapproval of a proposed substitution shall be final. If ENGINEER approves any proposed substitution, such approval will be set forth in an Addendum issued to all prospective Bidders. Bidders shall not rely upon approvals made in any other manner.

## **ARTICLE 10 - SUBCONTRACTORS, SUPPLIERS AND OTHERS**

- 10.1 The OWNER may require the identity of certain Subcontractors, Suppliers, and other persons and organizations (including those who are to furnish the principal items of material and equipment) to be submitted to OWNER in advance of the Notice of Award. The apparent Successful Bidder, and any other Bidder if requested shall within seven (7) days after the Bid opening submit to the OWNER a list of all such Subcontractors, Suppliers, and other persons and organizations proposed for those portions of the Work for which such identification is required. Such list shall be accompanied by an experience statement with pertinent information regarding similar projects and other evidence of qualification of each such Subcontractor, Supplier, person or organization if requested by the OWNER.
- 10.2 If OWNER or ENGINEER after due investigation has reasonable objection to any proposed Subcontractor, Supplier, other person or organization, either may before the Notice of Award is given request the apparent Successful Bidder to submit an acceptable substitute in which case the apparent Successful Bidder shall submit an acceptable substitute, that Bidder's bid price will be increased (or decreased) by the difference in cost occasioned by such substitution and OWNER may consider such price adjustment in evaluating Bids and making the contract award. If apparent Successful Bidder declines to make any such substitution, OWNER may award the contract to the next lowest Bidder that proposes to use acceptable Subcontractors, Suppliers, and other persons and organizations. The declining to make requested substitutions will not constitute grounds for sacrificing the Bid Security of any Bidder.
- 10.3 Any Subcontractor, Supplier, other person or organization listed and to whom OWNER or ENGINEER does not make written objection prior to the giving of the Notice of Award will be deemed acceptable to OWNER and ENGINEER, subject to revocation of such acceptance after the Effective Date of the Agreement as provided in Paragraph 7.06 of the General Conditions.
- 10.4 CONTRACTOR shall not be required to employ any Subcontractor, Supplier, individual, or entity against whom CONTRACTOR has reasonable objection.

## **ARTICLE 11 - BID FORM**

- 11.1 The Bid Form is included within the Contract Documents.
- 11.2 Bid Forms must be completed in ink or by typewriter. The Bid price of each item on the form must be stated in numerals.
- 11.3 Bids by corporations must be executed in the corporate name by the president or a vice-president (or other corporate officer accompanied by evidence of authority to sign) and the corporate seal must be affixed and attested by the secretary or an assistant secretary. The corporate address and state of incorporation must be shown below the signature.



- 11.4 Bids by partnerships must be executed in the partnership name and signed by a partner, whose title must appear under the signature and the official address of the partnership must be shown below the signature.
- 11.5 A Bid by a limited liability company shall be executed in the name of the firm by a member and accompanied by evidence of authority to sign. The state of formation of the firm and the official address of the firm must be shown below the signature.
- 11.6 A Bid by an individual shall show the Bidder's name and official address.
- 11.7 A Bid by a joint venture shall be executed by each joint venturer in the manner indicated on the Bid form. The official address of the joint venture must be shown below the signature.
- 11.8 All names must be typed or printed below the signature.
- 11.9 The bid shall contain an acknowledgment of receipt of all Addenda (the numbers of which must be filled in on the Bid Form).
- 11.10 The CCB Registration, business address and telephone number for communications regarding the Bid must be shown.

## **ARTICLE 12 - SUBMISSION OF BIDS**

- 12.1 To be responsive, bids shall be submitted at the time and place identified in the Advertisement or Invitation to Bid, be executed as detailed in these Instructions to Bidders and shall be enclosed in an opaque sealed envelope, marked with the Project Title (and, if applicable, the designated portion of the Project for which the Bid is submitted) and name and address of the Bidder and accompanied by the Bid Security and other required documents. If the Bid is sent through the mail or other delivery system, the sealed envelope shall be enclosed in a separate envelope with the notation "BID ENCLOSED" on the face of it.
- 12.2 To be responsive CONTRACTOR must complete, sign and submit the following documents:
  - a. Bid Proposal
  - b. Bid Bond
  - c. First Tier Disclosure

## **ARTICLE 13 - MODIFICATION AND WITHDRAWAL OF BIDS**

- 13.1 Bids may be modified or withdrawn by an appropriate document duly executed (in the manner that a Bid must be executed) and delivered to the place where the Bids are to be submitted at any time prior to the opening of Bids.

- 13.2 If, within twenty-four hours after Bids are opened, any Bidder files a duly signed, written notice with OWNER and promptly thereafter demonstrates to the reasonable satisfaction of OWNER that there was a material and substantial mistake in the preparation of its Bid, that Bidder may withdraw its Bid and the Bid Security will be returned. Thereafter, that Bidder will be disqualified from further bidding on the Work to be provided under the Contract Documents.

#### **ARTICLE 14 - OPENING OF BIDS**

- 14.1 Bids will be opened and read aloud publicly. An abstract of the amounts of the base Bids and major alternates (if any) may be made available to Bidders after the opening of the Bids.

#### **ARTICLE 15 - BIDS TO REMAIN SUBJECT TO ACCEPTANCE**

- 15.1 All bids will remain subject to acceptance for thirty (30) days after the day of the Bid opening, but OWNER may, in its sole discretion, release any Bid and return the Bid Security prior to that date.

#### **ARTICLE 16 - AWARD OF CONTRACT**

- 16.1 OWNER reserves the right to reject any and all Bids, to waive any and all informalities not involving price, time, or changes in the Work and to negotiate contract terms with the Successful Bidder, and the right to disregard all nonconforming, non-responsive, unbalanced, or conditional Bids. Also, OWNER reserves the right to reject the Bid of any Bidder if OWNER determines the Bid to be non-responsive per ORS 279B.110. In the event of discrepancy between the written and numerical amounts the written prices will govern. Discrepancies in the multiplication of units of Work and unit price will be resolved in favor of the unit prices. Discrepancies between the indicated sum of any column of figures and the correct sum thereof will be resolved in favor of the correct sum.
- 16.2 In evaluating Bids, OWNER will consider the qualifications of the Bidders, whether or not the Bids comply with the prescribed requirements, and such alternates, unit prices, and other data, as may be requested in the Bid Form or prior to the Notice of Award.
- 16.3 OWNER may consider the qualifications and experience of Subcontractors, Suppliers, and other persons and organizations proposed for those portions of the Work as to which the identity of Subcontractors, Suppliers, and other persons and organizations must be submitted as provided in the Supplementary Conditions.

OWNER also may consider the operating costs, maintenance requirements, performance data, and guarantees of major items of materials and equipment proposed for incorporation in the Work when such data is required to be submitted prior to the Notice of Award.

- 16.4 OWNER may conduct such investigations as OWNER deems necessary to assist in the evaluation of any Bid and to establish the responsibility, qualifications and financial ability of Bidders, proposed Subcontractors, Suppliers, and other persons and organizations to perform and furnish the Work in accordance with the Contract Documents to OWNER'S satisfaction within the prescribed time.
- 16.5 If the contract is to be awarded, the award will be based upon the lowest responsive/responsible bid for the total of the Basic Bid and such alternatives that in the sole judgement of the OWNER will best serve its interests.
- 16.6 If the contract is to be awarded, OWNER will give the Successful Bidder a Notice of Award within thirty (30) days after the Bid opening.
- 16.7 More than one Bid for the same Work from an individual or entity under the same or different names will not be considered. Reasonable grounds for believing that any Bidder has an interest in more than one Bid for the Work may be cause for disqualification of that Bidder and the rejection of all Bids in which that Bidder has an interest.

#### **ARTICLE 17 - CONTRACT SECURITY**

- 17.1 Prior to execution of the Contract, the Bidder shall furnish separate bonds covering the faithful performance of the Contract and the payment of all obligations arising thereunder, each in an amount equal to 100 percent of the Contract Sum. The cost of the furnishing of such bonds shall be included in the Bid. The Surety issuing such bonds shall be licensed to issue bonds in the State of Oregon. Such bonds shall comply with the provisions of Article 6 of the General Conditions.

#### **ARTICLE 18 - SIGNING OF AGREEMENT**

- 18.1 When OWNER gives a Notice of Award to the Successful Bidder, it will be accompanied by three unsigned counterparts of the Agreement with all other written Contract Documents attached. Within ten (10) days thereafter, Contractor shall sign and deliver the counterparts of the Agreement and attached documents to OWNER with the required Bonds. Within twenty-five (25) days thereafter, OWNER shall deliver one fully signed counterpart to Contractor. Each counterpart shall include a complete set of Drawings attached by reference.

#### **ARTICLE 19 - CONFERENCES**

##### **19.1 PRE-BID CONFERENCE**

If a pre-bid conference is specified in the Notice to Contractors, it shall be non-mandatory. If so scheduled, representatives of OWNER and ENGINEER will be present to discuss the Project. Bidders are encouraged to attend and participate in the conference. ENGINEER will transmit to all prospective

Bidders of record such Addenda as ENGINEER considers necessary in response to questions arising at the conference. Oral statements may not be relied upon and will not be binding or legally effective. The time and date of the pre-bid meeting will be provided by the Engineer.

## 19.2 PRECONSTRUCTION CONFERENCE

Either before or soon after the actual award of the Contract (but in any event prior to the start of Work at the site), the Contractor or his representative, and his subcontractors, shall attend a Preconstruction Conference with representatives of the OWNER, the funding agencies and the ENGINEER. The Conference will be held for review and acceptance of schedules referred to in paragraph 2.04 of the General Conditions, to establish procedures for handling shop drawings and other submittal and for processing applications for payment, and to acquaint the participants with the general plan of contract administration and requirements under which the construction operation is to proceed. The date, time, and place of the Conference will be furnished to the Contractor by the OWNER. The Contractor will notify his subcontractors of the Conference and require their attendance.

## ARTICLE 20 - IDENTIFICATION

- 20.1 The word "OWNER" as used herein refers to the CITY OF CANBY, as identified in the proposal, with whom the CONTRACTOR will enter into an agreement for the work. The OWNER shall be responsible for actions requested by the ENGINEER including payment in accordance with the terms of the Contract.
- 20.2 The word "ENGINEER" as used throughout these documents refers to the firm of CURRAN-McLEOD, INC. Consulting Engineers. All correspondence, notifications and requests of the OWNER by the CONTRACTOR shall be through the ENGINEER.
- 20.3 The word "CONTRACTOR" refers to the corporation, partnership or sole proprietorship which enters into a contractual obligation with the OWNER to complete the work. Subcontractors shall not be recognized.

## ARTICLE 21 - FIRST -TIER SUBCONTRACTOR DISCLOSURE

- 21.1 Within two working hours after the date and time of the deadline when bids are due to a contracting agency for a public improvement contract, a bidder shall submit to the contracting agency a disclosure of the first-tier subcontractors that:
- (A) Will be furnishing labor or will be furnishing labor and materials in connection with the public improvement contract; and
  - (B) Will have a contract value that is equal to or greater than five percent of the total project bid, or \$15,000, whichever is greater, or \$350,000 regardless of the percentage of the total project bid.
- 21.2 The disclosure of first-tier subcontractors under this subsection must include the name of each subcontractor, the category of work that each subcontractor will perform and the dollar value of each subcontract. The information shall be disclosed in the form provided in this bid document.
- 21.3 If the Bidder will not be using any Subcontractors that are subject to the above disclosure requirements, you are required to indicate "NONE" on the accompanying form.
- 21.4 THE OWNER MUST REJECT A BID IF THE BIDDER FAILS TO SUBMIT THE DISCLOSURE FORM WITH THIS INFORMATION BY THE STATED DEADLINE, EVEN IF NO SUBCONTRACTORS ARE LARGE ENOUGH TO BE DISCLOSED PER OAR 125-249-0360.



**BID PROPOSAL**



**REVISED BID PROPOSAL**

TO: Mr. Jerry Nelzen  
Public Works Operations Supervisor  
City of Canby  
222 NE 2<sup>nd</sup> Avenue  
Canby, OR 97013

2/19, 2019

The undersigned is a (indicate one):

RESIDENT     NON RESIDENT

bidder as defined by ORS 279A.120, structured as (check one of the following and insert information requested):

- a. A Corporation organized and existing under laws of the State of OREGON; or
- b. A Partnership registered under the laws of the State of \_\_\_\_\_; or
- c. An individual doing business under an assumed name registered under the laws of the State of \_\_\_\_\_.

The undersigned bidder declares that the only persons or parties interested in this proposal are those named herein, that this proposal is in all respects fair and without fraud and that it is made without collusion with any representatives of the OWNER.

The bidder further declares that: a) he has examined the plans, specifications, and other proposed contract documents; b) he has determined the extent, character, and location of the proposed Work, the nature and type of excavation to be done, the location and condition of existing streets and roadways giving access to the site of the Work, and topography of the site of the Work; and c) he has personally inspected the site of the Work and has satisfied himself as to the conditions of the Work and understands the listing of materials as included herein is brief and is intended only to associate the said quantities with detailed requirements of the contract documents.

The bidder does hereby propose to furnish all materials, tools, equipment, and appliances, and to perform all labor and work necessary to construct and complete the project entitled:

**City of Canby  
N Maple Street Improvements**

and all specified work appurtenant thereto, and in connection with this project for the OWNER with the time limit specified, and in accordance with plans, specifications and change order documents prepared by the ENGINEER for the sums set forth in the following schedule of prices, it being understood that the unit prices are independent of the exact quantities involved and that they represent a true measure of the labor and materials required to perform the Work.

The successful bidder agrees that if this proposal is accepted, bidder will execute the required documents and supply the required submittal information as specified herein, within the time frames established herein.

The successful bidder agrees to be substantially complete with all work within 60 days of the Notice to Proceed, and achieve final completion within 15 calendar days after issuance of the Certificate of Substantial Completion including punch list items.

In the event the successful bidder fails to achieve Substantial Completion or Final Completion of the project within the time limits specified or extended time limits as agreed upon, liquidated damages shall be paid to the OWNER or deducted from amounts due the Contractor, at the rate of Four Hundred Dollars (\$400.00) per calendar day until Substantial Completion is achieved, and/or until Final Completion is achieved. Sundays and legal holidays shall be excluded in determining the number of days in default.

The project will be awarded based on the low responsive bid for all the work listed in the basic bid schedule below.

**BASIC BID SCHEDULE - N Maple Street Improvements:**

Item No.	Description	Quantity	Unit	Unit Price	Total
<b>A. Site Preparation &amp; Restoration</b>					
A-1	Mobilization, Bond & Insurance	All	Lump Sum	17,500 <sup>00</sup>	17,500 <sup>00</sup>
A-2	Temporary Protection & Direction of Traffic, Temporary Signing	All	LS	7000 <sup>00</sup>	7000 <sup>00</sup>
A-3	Erosion Control & Spill Prevention Control & Countermeasure (SPCC) Plans	All	LS	5000 <sup>00</sup>	5000 <sup>00</sup>
A-4	Clearing & Grubbing, Tree Removal & Landscape Protection, Site Restoration	All	LS	9000 <sup>00</sup>	9000 <sup>00</sup>
A-5	Common Excavation	1,850	CY	28 <sup>00</sup>	51,800 <sup>00</sup>
A-6	Subgrade/ Trench Stabilization	50	CY	80 <sup>00</sup>	4,000 <sup>00</sup>
A-7	Sawcut Asphalt/ Concrete Pavement (All Depth)	350	LF	3 <sup>00</sup>	1,050 <sup>00</sup>
A-8	Install four (4) Traffic Signs on two (2) Posts	4	Each	185 <sup>00</sup>	740 <sup>00</sup>
A-9	Remove, Salvage and Reinstall Existing Mail / Newspaper Boxes on New Post With New V-Loc Base (Multiple)	5	Each	400 <sup>00</sup>	2,000 <sup>00</sup>
A-10	Remove, Salvage and Reinstall Existing Mail / Newspaper Box on New Post With New V-Loc Base (Single)	3	Each	300 <sup>00</sup>	900 <sup>00</sup>
A-11	Remove, Salvage & Relocate Existing Decorative Mail Box to New Sidewalk	2	Each	300 <sup>00</sup>	600 <sup>00</sup>
A-12	Continental Cross Bars & Stop Bars	150	SF	12 <sup>00</sup>	1,800 <sup>00</sup>
Subtotal					101,390 <sup>00</sup>
<b>B. Paving &amp; Surfacing</b>					
B-1	1"-0" Crushed Rock Base (12" deep)	4,425	SY	14 <sup>50</sup>	64,162 <sup>50</sup>
B-2	Standard Concrete Curb & Gutter including Excavation and 6" Leveling Rock	2,335	LF	22 <sup>00</sup>	51,370 <sup>00</sup>
B-3	Short Concrete Curb at back of ADA Ramps	64	LF	33 <sup>00</sup>	2,112 <sup>00</sup>
B-4	6" Concrete Residential Driveway including Excavation and 4" Leveling Rock	300	SY	82 <sup>00</sup>	24,600 <sup>00</sup>
B-5	4" Concrete Sidewalk or Driveway including Excavation and 2" Leveling Rock	1,100	SY	55 <sup>00</sup>	60,500 <sup>00</sup>

B-6	Detectable Warning Tile (ADA Ramp)	4	Each	250 <sup>00</sup>	1,000 <sup>00</sup>
B-7	Asphalt Driveway Restoration including Excavation and 8" Leveling Rock	100	SY	40 <sup>00</sup>	4,000 <sup>00</sup>
B-8	Gravel Driveway Restoration including Excavation and 4" Leveling Rock	40	SY	30 <sup>00</sup>	1,200 <sup>00</sup>
B-9	½" Dense Mix AC Pavement, Level II	1,100	Tons	76 <sup>00</sup>	83,600 <sup>00</sup>
B-10	Precast Concrete Manorstone Block Retaining Wall (Gray Color Units)	250	SF	22 <sup>00</sup>	5,500 <sup>00</sup>
B-11	Minor Exist Manhole/Cleanout Adjustment to Grade	6	Each	450 <sup>00</sup>	2,700 <sup>00</sup>
Subtotal					300,744 <sup>50</sup>
<b>C. Storm Drain Improvements</b>					
C-1	10" PVC C900 Pipe including Trench Excavation & Material Disposal and Compacted Crushed Rock Backfill	9	LF	180 <sup>00</sup>	1,620 <sup>00</sup>
C-1A	10" PVC 3034 Pipe including Trench Excavation & Material Disposal and Compacted Crushed Rock Backfill	26	LF	85 <sup>00</sup>	2,210 <sup>00</sup>
C-2	Remove Exist Catch Basin & Cap End of Pipe	2	Each	550 <sup>00</sup>	1,100 <sup>00</sup>
C-3	Type G-2 Catch Basin	2	Each	1,600 <sup>00</sup>	3,200 <sup>00</sup>
C-4	Waite Catch Basin	2	Each	1,600 <sup>00</sup>	3,200 <sup>00</sup>
C-5	New Drywell	1	Each	24,000 <sup>00</sup>	24,000 <sup>00</sup>
C-6	Connect to Exist Drywell	1	Each	350 <sup>00</sup>	350 <sup>00</sup>
Subtotal					35,680 <sup>00</sup>
<b>D. Sanitary Sewer</b>					
D-1	6" Cleanout Assembly over Exist 6" Concrete Pipe Including Trench Excavation & Material Disposal and Crushed Rock Backfill	22	Each	2,000 <sup>00</sup>	44,000 <sup>00</sup>
D-2	New 6" PVC 3034 Sewer Lateral with 6" Cleanout including Trench Excavation & Material Disposal and Compacted Crushed Rock Backfill (long run)	3	Each	3,000 <sup>00</sup>	9,000 <sup>00</sup>
D-3	New 6" PVC 3034 Sewer Lateral with 6" Cleanout including Trench Excavation & Material Disposal and Compacted Crushed Rock Backfill (short run)	1	Each	1,800 <sup>00</sup>	1,800 <sup>00</sup>
Subtotal					54,800 <sup>00</sup>
<b>E. Waterlines</b>					
E-1	Remove & Salvage Exist Fire Hydrant including Removal of Spool and installing Blind Flange at Exist Valve, Trench Excavation & Material Disposal and Compacted Crushed Rock Backfill	1	Each	700 <sup>00</sup>	700 <sup>00</sup>
E-2	Relocate Exist Fire Hydrant including 12"x6" Hot Tap, 6" Valve, 6" DI Spool Trench Excavation & Material Disposal and Compacted Crushed Rock Backfill	1	Each	6,000 <sup>00</sup>	6,000 <sup>00</sup>
E-3	New 1" PET Water Service including Trench Excavation & Material Disposal and Compacted Crushed Rock Backfill (long run)	3	Each	3,000 <sup>00</sup>	9,000 <sup>00</sup>

E-4	New 1" PET Water Service including Trench Excavation & Material Disposal and Compacted Crushed Rock Backfill (short run)	1	Each	2800 <sup>00</sup>	2800 <sup>00</sup>
E-4	New 1 1/2" PET Water Service including Trench Excavation & Material Disposal and Compacted Crushed Rock Backfill	1	Each	9000 <sup>00</sup>	9000 <sup>00</sup>
Subtotal					27,500 <sup>00</sup>
<b>F. Utility Construction</b>					
F-1	Excavate and Backfill For Street Light Poles and Backfill with Compacted Crushed Rock	9	Each	315 <sup>00</sup>	2835 <sup>00</sup>
Subtotal					2835 <sup>00</sup>
<b>TOTAL BASIC BID SCHEDULE</b>					<b>522,949<sup>50</sup></b>

**TOTAL BASIC BID SCHEDULE: \$ 522,949<sup>50</sup>**

Accompanying herewith is Bid Security which is equal to five percent (5%) of the total amount of the Basic Bid.

The undersigned agrees, if awarded the Contract, to execute and deliver to the OWNER within fifteen (15) days after receiving the Contract forms, an Agreement and satisfactory Construction Performance and Construction Payment Bonds each in an amount equal to one hundred percent (100%) of the Contract sum, using forms provided therefor by the OWNER. The Surety requested to issue the Construction Performance Bond will be:

WESTERN SURETY CO.  
 (Name of Surety Company)  
ANCHOR INSURANCE (503) 224-2500  
 (Agent Name & Phone Number)

The undersigned hereby authorizes said Surety to disclose any information to the OWNER concerning the undersigned's ability to supply a Construction Performance Bond in the amount of the Contract.

The undersigned certifies that (1) this Bid has been arrived at independently and is being submitted without collusion with, and without any agreement, understanding, or planned common course of action with, any other vendor of materials, supplies, equipment, or services described in the Advertisement for Bids designed to limit independent bidding or competition, (2) the contents of this Bid have not been communicated by the undersigned or its employees or agents to any person not an employee or agent of the undersigned or its surety on any bond furnished with the Bid and will not be communicated to such person prior to the official opening of the bids, and (3) if awarded the Contract, he will commence work within ten (10) calendar days after the date of Notice to Proceed and that he will complete the Work within the specified number of days set forth in the Agreement.

The undersigned certifies that he has received and duly considered the following Addenda to the specifications.

Addenda: No. 1 to No. \_\_\_\_\_ inclusive.

The undersigned agrees if awarded the Contract, that he will comply with the provisions of the Contract Documents and will comply with the provisions of ORS 279C.800 and Oregon Prevailing Wage Rates.

Name of Firm EAGLE-ELSNER, INC.

Signature Richard Eagle, Pres

Name RICHARD EAGLE

Address P.O. BOX 23294 TIGARD, OR 97281

Telephone No. (503) 628-1137

Construction Contractors Board No. # 27112

If Corporation, Attest: Mary Newton  
Secretary of Corporation

\*If bid is by a partnership, then one of the partners must sign the bid.

*This Page Intentionally Left Blank*

**BID BOND**

**BID BOND**



### BID BOND

Any singular reference to Bidder, Surety, Owner or other party shall be considered plural where applicable.

**BIDDER (Name and Address):**

Eagle Elsner, Inc.  
P. O. Box 23294  
Tigard, OR 97281

**SURETY (Name, and Address of Principal Place of Business):**

Western Surety Company  
12909 SW 68th Parkway, Suite 200  
Portland, OR 97223

**OWNER (Name and Address):**

City of Canby  
222 NE 2nd Ave.  
Canby, OR 97013

**BID**

Bid Due Date: February 19, 2019

**Description (Project Name— Include Location):**

N Maple Street Improvements, Canby, Oregon

**BOND**

Bond Number: N/A

Date: February 19, 2019

Penal sum Five Percent of the Total Amount Bid

\$ 5%

(Words)

(Figures)

Surety and Bidder, intending to be legally bound hereby, subject to the terms set forth below, do each cause this Bid Bond to be duly executed by an authorized officer, agent, or representative.

**BIDDER**

**SURETY**

Eagle Elsner, Inc. (Seal)

Western Surety Company (Seal)

Bidder's Name and Corporate Seal

Surety's Name and Corporate Seal

By:

Richard Eagle, Pres  
Signature

By:

Gloria Bruning  
Signature (Attach Power of Attorney)

RICHARD EAGLE

Print Name

Gloria Bruning

Print Name

PRESIDENT

Title

Attorney-in-Fact

Title

Attest:

Mary Neuron  
Signature

Attest:

Phil O. Ihm  
Signature

Title

Witness for Surety

Title

Note: Addresses are to be used for giving any required notice.

Provide execution by any additional parties, such as joint venturers, if necessary.

1. Bidder and Surety, jointly and severally, bind themselves, their heirs, executors, administrators, successors, and assigns to pay to Owner upon default of Bidder the penal sum set forth on the face of this Bond. Payment of the penal sum is the extent of Bidder's and Surety's liability. Recovery of such penal sum under the terms of this Bond shall be Owner's sole and exclusive remedy upon default of Bidder.
2. Default of Bidder shall occur upon the failure of Bidder to deliver within the time required by the Bidding Documents (or any extension thereof agreed to in writing by Owner) the executed Agreement required by the Bidding Documents and any performance and payment bonds required by the Bidding Documents.
3. This obligation shall be null and void if:
  - 3.1 Owner accepts Bidder's Bid and Bidder delivers within the time required by the Bidding Documents (or any extension thereof agreed to in writing by Owner) the executed Agreement required by the Bidding Documents and any performance and payment bonds required by the Bidding Documents, or
  - 3.2 All Bids are rejected by Owner, or
  - 3.3 Owner fails to issue a Notice of Award to Bidder within the time specified in the Bidding Documents (or any extension thereof agreed to in writing by Bidder and, if applicable, consented to by Surety when required by Paragraph 5 hereof).
4. Payment under this Bond will be due and payable upon default of Bidder and within 30 calendar days after receipt by Bidder and Surety of written notice of default from Owner, which notice will be given with reasonable promptness, identifying this Bond and the Project and including a statement of the amount due.
5. Surety waives notice of any and all defenses based on or arising out of any time extension to issue Notice of Award agreed to in writing by Owner and Bidder, provided that the total time for issuing Notice of Award including extensions shall not in the aggregate exceed 120 days from the Bid due date without Surety's written consent.
6. No suit or action shall be commenced under this Bond prior to 30 calendar days after the notice of default required in Paragraph 4 above is received by Bidder and Surety and in no case later than one year after the Bid due date.
7. Any suit or action under this Bond shall be commenced only in a court of competent jurisdiction located in the state in which the Project is located.
8. Notices required hereunder shall be in writing and sent to Bidder and Surety at their respective addresses shown on the face of this Bond. Such notices may be sent by personal delivery, commercial courier, or by United States Registered or Certified Mail, return receipt requested, postage pre-paid, and shall be deemed to be effective upon receipt by the party concerned.
9. Surety shall cause to be attached to this Bond a current and effective Power of Attorney evidencing the authority of the officer, agent, or representative who executed this Bond on behalf of Surety to execute, seal, and deliver such Bond and bind the Surety thereby.
10. This Bond is intended to conform to all applicable statutory requirements. Any applicable requirement of any applicable statute that has been omitted from this Bond shall be deemed to be included herein as if set forth at length. If any provision of this Bond conflicts with any applicable statute, then the provision of said statute shall govern and the remainder of this Bond that is not in conflict therewith shall continue in full force and effect.
11. The term "Bid" as used herein includes a Bid, offer, or proposal as applicable.

# Western Surety Company

## POWER OF ATTORNEY APPOINTING INDIVIDUAL ATTORNEY-IN-FACT

Know All Men By These Presents, That WESTERN SURETY COMPANY, a South Dakota corporation, is a duly organized and existing corporation having its principal office in the City of Sioux Falls, and State of South Dakota, and that it does by virtue of the signature and seal herein affixed hereby make, constitute and appoint

**Philip O Forker, Ray M Paiement, Vicki Mather, Gloria Bruning, Richard W Kowalski, Brent Olson, J Patrick Dooney, Karen A Pierce, Joel Dietzman, Christopher A Reburn, Gail A Price, Tami Jones, Individually**

of Portland, OR, its true and lawful Attorney(s)-in-Fact with full power and authority hereby conferred to sign, seal and execute for and on its behalf bonds, undertakings and other obligatory instruments of similar nature

### - In Unlimited Amounts -

and to bind it thereby as fully and to the same extent as if such instruments were signed by a duly authorized officer of the corporation and all the acts of said Attorney, pursuant to the authority hereby given, are hereby ratified and confirmed.

This Power of Attorney is made and executed pursuant to and by authority of the By-Law printed on the reverse hereof, duly adopted, as indicated, by the shareholders of the corporation.

In Witness Whereof, WESTERN SURETY COMPANY has caused these presents to be signed by its Vice President and its corporate seal to be hereto affixed on this 29th day of November, 2018.



WESTERN SURETY COMPANY

*Paul T. Bruflat*

Paul T. Bruflat, Vice President

State of South Dakota }  
County of Minnehaha } ss

On this 29th day of November, 2018, before me personally came Paul T. Bruflat, to me known, who, being by me duly sworn, did depose and say: that he resides in the City of Sioux Falls, State of South Dakota; that he is the Vice President of WESTERN SURETY COMPANY described in and which executed the above instrument; that he knows the seal of said corporation; that the seal affixed to the said instrument is such corporate seal; that it was so affixed pursuant to authority given by the Board of Directors of said corporation and that he signed his name thereto pursuant to like authority, and acknowledges same to be the act and deed of said corporation.

My commission expires

June 23, 2021



*J. Mohr*

J. Mohr, Notary Public

### CERTIFICATE

I, L. Nelson, Assistant Secretary of WESTERN SURETY COMPANY do hereby certify that the Power of Attorney hereinabove set forth is still in force, and further certify that the By-Law of the corporation printed on the reverse hereof is still in force. In testimony whereof I have hereunto subscribed my name and affixed the seal of the said corporation this 19th day of February, 2019.



WESTERN SURETY COMPANY

*L. Nelson*

L. Nelson, Assistant Secretary

**Authorizing By-Law**

**ADOPTED BY THE SHAREHOLDERS OF WESTERN SURETY COMPANY**

This Power of Attorney is made and executed pursuant to and by authority of the following By-Law duly adopted by the shareholders of the Company.

Section 7. All bonds, policies, undertakings, Powers of Attorney, or other obligations of the corporation shall be executed in the corporate name of the Company by the President, Secretary, and Assistant Secretary, Treasurer, or any Vice President, or by such other officers as the Board of Directors may authorize. The President, any Vice President, Secretary, any Assistant Secretary, or the Treasurer may appoint Attorneys in Fact or agents who shall have authority to issue bonds, policies, or undertakings in the name of the Company. The corporate seal is not necessary for the validity of any bonds, policies, undertakings, Powers of Attorney or other obligations of the corporation. The signature of any such officer and the corporate seal may be printed by facsimile.

**FIRST-TIER DISCLOSURE STATEMENT**

**FIRST-TIER DISCLOSURE STATEMENT**



# FIRST-TIER SUBCONTRACTOR DISCLOSURE

PROJECT NAME: N. MAPLE STREET IMPROVEMENTS

BID #: \_\_\_\_\_

BID CLOSING: Date: 2/19/19 Time: 2:00 pm

This form must be submitted at the location specified in the Invitation to Bid on the advertised bid closing date and within two working hours after the advertised bid closing time.

List below the name of each subcontractor that will be furnishing labor or will be furnishing labor and materials and that is required to be disclosed, the category of work that the subcontractor will be performing and the dollar value of the subcontract. Enter "NONE" if there are no subcontractors that need to be disclosed. (ATTACH ADDITIONAL SHEETS IF NEEDED.)

NAME	DOLLAR VALUE	CATEGORY OF WORK
(1) Roger Langelier	\$ 100,917.00	Concrete
(2)	\$	
(3)	\$	
(4)	\$	
(5)	\$	
(6)	\$	
(7)	\$	
(8)	\$	
(9)	\$	

Failure to submit this form by the disclosure deadline will result in a non-responsive bid. A non-responsive bid will not be considered for award.

Form submitted by (bidder name): EAGLE-ELSNER, INC.

Contact name: CURTIS COOKEY Phone no.: (503) 628-1137

- ORS 279C.370 First-tier subcontractor disclosure. (1)(a) Within two working hours after the date and time of the deadline when bids are due to a contracting agency for a public improvement contract, a bidder shall submit to the contracting agency a disclosure of the first-tier subcontractors that:
- (A) Will be furnishing labor or will be furnishing labor and materials in connection with the public improvement contract;
  - (B) Will have a contract value that is equal to or greater than five percent of the total project bid or \$15,000, whichever is greater, or \$350,000 regardless of the percentage of the total project bid.
    - (b) For each contract to which this subsection applies, the contracting agency shall designate a deadline for submission of bids that has a date on a Tuesday, Wednesday or Thursday and a time between 2 p.m. and 5 p.m., except that this paragraph does not apply to public contracts for maintenance or construction of highways, bridges or other transportation facilities.
    - (c) This subsection applies only to public improvement contracts ("projects") with a value, estimated by the contracting agency, of more than \$100,000.
    - (d) This subsection does not apply to public improvement contracts that have been exempted from competitive bidding requirements under ORS 279C.335 (2).
- (2) The disclosure of first-tier subcontractors under subsection (1) of this section must include the name of each subcontractor, the category of work that each subcontractor will perform and the dollar value of each subcontract. The information shall be disclosed in substantially the following [above] form:
- (3) A contracting agency shall accept the subcontractor disclosure. The contracting agency shall consider the bid of any contractor that does not submit a subcontractor disclosure to the contracting agency to be a non-responsive bid and may not award the contract to the contractor. A contracting agency is not required to determine the accuracy or the completeness of the subcontractor disclosure.
- (4) After the bids are opened, the subcontractor disclosures must be made available for public inspection.
- (5) A contractor may substitute a first-tier subcontractor under the provisions of ORS 279C.585.
- (6) A subcontractor may file a complaint under ORS 279C.590 based on the disclosure requirements of subsection (1) of this section.

*This Page Intentionally Left Blank*



**CONTRACT FOR CONSTRUCTION**

---

**CONTRACT FOR CONSTRUCTION**

## CONTRACT FOR CONSTRUCTION

THIS AGREEMENT is dated as of the 20<sup>th</sup> day of March in the year 2019 by and between

City of Canby

(hereinafter called OWNER) and

Eagle-Elsner, Inc.

(hereinafter called CONTRACTOR)

OWNER and CONTRACTOR, in consideration of the mutual covenants hereinafter set forth, agree as follows:

### ARTICLE 1 - WORK

CONTRACTOR shall complete all Work as specified or indicated in the Contract Documents:

**City of Canby**

#### **N Maple Street Improvements**

The scope of work consists of the following:

- Construction of approximately 1,300 lineal feet of street full street reconstruction to include excavation, new curbs and gutter, concrete sidewalks and driveways, installation of cleanouts over (22) existing 6" sanitary sewer laterals, add four (4) new sanitary sewer and water services, storm drainage to include one (1) new drywell and 4 catch basins, base coarse, pavement and site restoration.

### ARTICLE 2 - ENGINEER

The Project has been designed by CURRAN-McLEOD, INC., Consulting Engineers, who is hereinafter called ENGINEER and who will assume all duties and responsibilities and will have the rights and authority assigned to ENGINEER in the Contract Documents in connection with completion of the Work in accordance with the Contract Documents.

### ARTICLE 3 - CONTRACT TIME

- 3.1 The Work will be substantially completed within **60** calendar days after the date when the Contract Time commences to run as provided in paragraph 2.03 of the General Conditions, and completed and ready for final payment in accordance with Paragraph 15.07 of the General Conditions within 15 days after the date when the issuance of the Certificate of Substantial Completion including punch list items.

- 3.2 Liquidated Damages: OWNER and CONTRACTOR recognize that time is of the essence of this Agreement and that OWNER will suffer financial loss if the Work is not substantially complete within the time specified in paragraph 3.1 above, plus any extensions thereof allowed in accordance with Article 12 of the General Conditions. They also recognize the delays, expense and difficulties involved in proving in a legal proceeding the actual loss suffered by OWNER if the Work is not substantially complete on time.

Accordingly, instead of requiring any such proof, OWNER and CONTRACTOR agree that as liquidated damages for delay (but not as a penalty) CONTRACTOR shall pay OWNER or the OWNER may withhold from amounts due the CONTRACTOR Four Hundred Dollars (\$400.00) for each day that expires after the time specified in paragraph 3.1. for Substantial Completion until the Work is substantially complete AND/OR for each day of delay beyond the deadline for Final Completion.

#### **ARTICLE 4 - CONTRACT PRICE**

- 4.1 OWNER shall pay CONTRACTOR for performance of the Work in accordance with the Contract Documents in current funds by check, an amount totaling

Five Hundred Twenty-Two Thousand Nine Hundred Forty-Nine and 50/100 Dollars

(\$522,949.50) as shown in the attached Bid Proposal.

#### **ARTICLE 5 - PAYMENT PROCEDURES**

CONTRACTOR shall submit Applications for Payment in accordance with Article 14 of the General Conditions. Applications for Payment will be processed by ENGINEER as provided in the General Conditions.

- 5.1 Progress Payments: OWNER shall make progress payments on account of the Contract Price on the basis of CONTRACTOR'S Applications for Payment as recommended by ENGINEER, on or about the 25th day of each month during construction as provided below. All progress payments will be on the basis of the progress of the Work measured by the schedule of values provided for in paragraph 2.03 of the General Conditions.

- 5.1.1 Prior to Substantial Completion progress payments will be in an amount equal to:

- (a) 95 % of the Work completed; and
- (b) 95 % of materials and equipment not incorporated in the Work but delivered and suitably stored, less in each case the aggregate of payments previously made.

- 5.1.2 Upon Substantial Completion, OWNER shall pay an amount sufficient to increase total payments to CONTRACTOR to 95% of the value of the Contract Work completed, less such amounts as ENGINEER shall determine in accordance with paragraph 14.02 of the General Conditions.
- 5.2 Final Payment: Upon final completion and acceptance of the Work in accordance with paragraph 15.06 of the General Conditions, OWNER shall pay the remainder of the value of the Contract Work completed, as recommended by ENGINEER as provided in said paragraph 14.07.

## **ARTICLE 6 - INTEREST**

All monies not paid when due hereunder shall bear interest at the maximum rate allowed by law at the place of the Project, when requested in accordance with ORS 279C.570

## **ARTICLE 7 - CONTRACTOR'S REPRESENTATIONS**

In order to induce OWNER to enter into this Agreement CONTRACTOR makes the following representations:

- 7.1 CONTRACTOR has familiarized himself with the nature and extent of the Contract Documents, Work, locality, and with all local conditions and federal, state and local laws, ordinances, rules and regulations that in any manner may affect cost, progress or performance of the Work.
- 7.2 CONTRACTOR has visited and explored the site soil conditions or if attached studied carefully all reports of investigations and tests of subsurface and latent physical conditions at the site or otherwise affecting cost, progress or performance of the Work which were relied upon by ENGINEER in the preparation of the Drawings and Specifications and which have been identified in the Supplementary Conditions.
- 7.3 CONTRACTOR has visited and explored the site soil conditions, made or caused to be made if attached examinations, investigations and tests and studies of such reports and related data in addition to those referred to in paragraph 7.2 as he deems necessary for the performance of the Work at the Contract Price, within the Contract Time and in accordance with the other terms and conditions of the Contract Documents; and no additional examinations, investigations, tests, reports or similar data are or will be required by CONTRACTOR for such purposes.
- 7.4 CONTRACTOR has conversed with the ENGINEER regarding the site soil conditions or correlated if attached the results of all such observations, examinations, investigations, tests, reports and data with the terms and conditions of the Contract Documents.

7.5 CONTRACTOR has given ENGINEER written notice of all conflicts, errors or discrepancies that he has discovered in the Contract Documents and the written resolution thereof by ENGINEER is acceptable to CONTRACTOR.

7.6 Large boulders are expected to be encountered on-site during trench excavation.

## **ARTICLE 8 - CONTRACT DOCUMENTS**

8.1 This Agreement

8.2 Exhibits to this Agreement.

8.3 Performance and other Bonds

8.4 Notice of Award.

8.5 General Conditions of the Construction Contract

8.6 Supplementary Conditions

8.7 Technical Specifications as listed in the Table of Contents.

8.8 Drawings & Specifications bearing the following general title:  
City of Canby  
N Maple Street Improvements

8.9 Addenda numbers 1.

8.10 CONTRACTOR'S Bid

8.11 Any Modification, including Change Orders, duly delivered after execution of Agreement.

There are no Contract Documents other than those listed above in this ARTICLE 8. The Contract Documents may only be altered, amended or repealed by a Modification (as defined in Article 1 of the General Conditions).

## **ARTICLE 9 - MISCELLANEOUS**

9.1 Terms used in this Agreement which are defined in Article 1 of the General Conditions shall have the meanings indicated in the General Conditions.

9.2 No assignment by a party hereto of any rights under or interests in the Contract Documents will be binding on another party hereto without the written consent of the party sought to be bound; and specifically by without limitation, moneys that may become due and moneys that are due may not be assigned without such consent (except to the extent that the effect of this restriction may be limited by law), and

unless specifically stated to the contrary in any written consent to an assignment no assignment will release or discharge the assignor from any duty or responsibility under the Contract Documents.

9.3 OWNER and CONTRACTOR each binds himself, his partners, successors, assigns and legal representatives to the other party hereto, his partners, successors, assigns and legal representatives in respect to all covenants, agreements and obligations contained in the Contract Documents.

9.4 In the event a suit, arbitration or other legal action is required by either the OWNER or the CONTRACTOR to enforce any provisions of this Agreement, the prevailing parties shall be entitled to all reasonable costs and reasonable attorney's fees upon trial or subsequent appeal.

IN WITNESS WHEREOF, the parties hereto have signed three counterparts of this Agreement.

This Agreement will be effective on March 20, 2019.

OWNER:

City of Canby  
P.O. Box 930  
Canby, OR 97013

By: 

Name/Title: Brian Hodson

Name/Title: Mayor

CONTRACTOR:

Eagle-Elsner, Inc.  
17400 SW Hillsboro Hwy  
Sherwood, OR 97140

By: 

Name/Title: Richard Eagle, President

Attest: 

Address for giving notices:

PO Box 23294  
Tigard, Or. 97281

**CONSTRUCTION PERFORMANCE BOND**



**CONSTRUCTION PERFORMANCE BOND**

**PERFORMANCE BOND**

**CONTRACTOR** (name and address):

Eagle Elsner, Inc.  
PO Box 23294  
Tigard, OR 97281

**SURETY** (name and address of principal place of business):

Western Surety Company  
12909 SW 68th Parkway, Suite 200  
Portland, OR 97223

**OWNER** (name and address):

City of Canby  
222 NE 2nd Ave.  
Canby, OR 97013

**CONSTRUCTION CONTRACT**

Effective Date of the Agreement: March 20, 2019

Amount: Five Hundred Twenty Two Thousand Nine Hundred Forty Nine & 50/100---(\$522,949.50) Dollars

Description (name and location): City of Canby  
N Maple Street Improvements

**BOND**

Bond Number: 30062422

Date (not earlier than the Effective Date of the Agreement of the Construction Contract): March , 2019

Amount: Five Hundred Twenty Two Thousand Nine Hundred Forty Nine & 50/100---(\$522,949.50) Dollars

Modifications to this Bond Form:  None  See Paragraph 16

Surety and Contractor, intending to be legally bound hereby, subject to the terms set forth below, do each cause this Performance Bond to be duly executed by an authorized officer, agent, or representative.

**CONTRACTOR AS PRINCIPAL**

Eagle Elsner, Inc. \_\_\_\_\_ (seal)  
Contractor's Name and Corporate Seal

By: Richard Eagle, Pres  
Signature

Richard Eagle  
Print Name

President  
Title

Attest: Mary Morrow  
Signature

Secretary  
Title

**SURETY**

Western Surety Company \_\_\_\_\_ (seal)  
Surety's Name and Corporate Seal

By: Gloria Bruning  
Signature (attach power of attorney)

Gloria Bruning  
Print Name

\_\_\_\_\_  
Attorney-in-fact  
Title

Attest: Julia  
Signature

\_\_\_\_\_  
Agent-Witness for Surety  
Title

**Notes: (1) Provide supplemental execution by any additional parties, such as joint venturers. (2) Any singular reference to Contractor, Surety, Owner, or other party shall be considered plural where applicable.**

1. The Contractor and Surety, jointly and severally, bind themselves, their heirs, executors, administrators, successors, and assigns to the Owner for the performance of the Construction Contract, which is incorporated herein by reference.

2. If the Contractor performs the Construction Contract, the Surety and the Contractor shall have no obligation under this Bond, except when applicable to participate in a conference as provided in Paragraph 3.

3. If there is no Owner Default under the Construction Contract, the Surety's obligation under this Bond shall arise after:

3.1 The Owner first provides notice to the Contractor and the Surety that the Owner is considering declaring a Contractor Default. Such notice shall indicate whether the Owner is requesting a conference among the Owner, Contractor, and Surety to discuss the Contractor's performance. If the Owner does not request a conference, the Surety may, within five (5) business days after receipt of the Owner's notice, request such a conference. If the Surety timely requests a conference, the Owner shall attend. Unless the Owner agrees otherwise, any conference requested under this Paragraph 3.1 shall be held within ten (10) business days of the Surety's receipt of the Owner's notice. If the Owner, the Contractor, and the Surety agree, the Contractor shall be allowed a reasonable time to perform the Construction Contract, but such an agreement shall not waive the Owner's right, if any, subsequently to declare a Contractor Default;

3.2 The Owner declares a Contractor Default, terminates the Construction Contract and notifies the Surety; and

3.3 The Owner has agreed to pay the Balance of the Contract Price in accordance with the terms of the Construction Contract to the Surety or to a contractor selected to perform the Construction Contract.

4. Failure on the part of the Owner to comply with the notice requirement in Paragraph 3.1 shall not constitute a failure to comply with a condition precedent to the Surety's obligations, or release the Surety from its obligations, except to the extent the Surety demonstrates actual prejudice.

5. When the Owner has satisfied the conditions of Paragraph 3, the Surety shall promptly and at the Surety's expense take one of the following actions:

5.1 Arrange for the Contractor, with the consent of the Owner, to perform and complete the Construction Contract;

5.2 Undertake to perform and complete the Construction Contract itself, through its agents or independent contractors;

5.3 Obtain bids or negotiated proposals from qualified contractors acceptable to the Owner for a contract for performance and completion of the Construction Contract, arrange for a contract to be prepared for execution by the

Owner and a contractor selected with the Owners concurrence, to be secured with performance and payment bonds executed by a qualified surety equivalent to the bonds issued on the Construction Contract, and pay to the Owner the amount of damages as described in Paragraph 7 in excess of the Balance of the Contract Price incurred by the Owner as a result of the Contractor Default; or

5.4 Waive its right to perform and complete, arrange for completion, or obtain a new contractor, and with reasonable promptness under the circumstances:

5.4.1 After investigation, determine the amount for which it may be liable to the Owner and, as soon as practicable after the amount is determined, make payment to the Owner; or

5.4.2 Deny liability in whole or in part and notify the Owner, citing the reasons for denial.

6. If the Surety does not proceed as provided in Paragraph 5 with reasonable promptness, the Surety shall be deemed to be in default on this Bond seven days after receipt of an additional written notice from the Owner to the Surety demanding that the Surety perform its obligations under this Bond, and the Owner shall be entitled to enforce any remedy available to the Owner. If the Surety proceeds as provided in Paragraph 5.4, and the Owner refuses the payment or the Surety has denied liability, in whole or in part, without further notice the Owner shall be entitled to enforce any remedy available to the Owner.

7. If the Surety elects to act under Paragraph 5.1, 5.2, or 5.3, then the responsibilities of the Surety to the Owner shall not be greater than those of the Contractor under the Construction Contract, and the responsibilities of the Owner to the Surety shall not be greater than those of the Owner under the Construction Contract. Subject to the commitment by the Owner to pay the Balance of the Contract Price, the Surety is obligated, without duplication for:

7.1 the responsibilities of the Contractor for correction of defective work and completion of the Construction Contract;

7.2 additional legal, design professional, and delay costs resulting from the Contractor's Default, and resulting from the actions or failure to act of the Surety under Paragraph 5; and

7.3 liquidated damages, or if no liquidated damages are specified in the Construction Contract, actual damages caused by delayed performance or non-performance of the Contractor.

8. If the Surety elects to act under Paragraph 5.1, 5.3, or 5.4, the Surety's liability is limited to the amount of this Bond.

9. The Surety shall not be liable to the Owner or others for obligations of the Contractor that are unrelated to the Construction Contract, and the Balance of the Contract Price shall not be reduced or set off on account of any such unrelated obligations. No right of action shall accrue on this Bond to any person or entity other than

the Owner or its heirs, executors, administrators, successors, and assigns.

10. The Surety hereby waives notice of any change, including changes of time, to the Construction Contract or to related subcontracts, purchase orders, and other obligations.

11. Any proceeding, legal or equitable, under this Bond may be instituted in any court of competent jurisdiction in the location in which the work or part of the work is located and shall be instituted within two years after a declaration of Contractor Default or within two years after the Contractor ceased working or within two years after the Surety refuses or fails to perform its obligations under this Bond, whichever occurs first. If the provisions of this paragraph are void or prohibited by law, the minimum periods of limitations available to sureties as a defense in the jurisdiction of the suit shall be applicable.

12. Notice to the Surety, the Owner, or the Contractor shall be mailed or delivered to the address shown on the page on which their signature appears.

13. When this Bond has been furnished to comply with a statutory or other legal requirement in the location where the construction was to be performed, any provision in this Bond conflicting with said statutory or legal requirement shall be deemed deleted herefrom and provisions conforming to such statutory or other legal requirement shall be deemed incorporated herein. When so furnished, the intent is that this Bond shall be construed as a statutory bond and not as a common law bond.

#### 14. Definitions

14.1 Balance of the Contract Price: The total amount payable by the Owner to the Contractor under the Construction Contract after all proper adjustments have been made including

allowance for the Contractor for any amounts received or to be received by the Owner in settlement of insurance or other claims for damages to which the Contractor is entitled, reduced by all valid and proper payments made to or on behalf of the Contractor under the Construction Contract.

14.2 Construction Contract: The agreement between the Owner and Contractor identified on the cover page, including all Contract Documents and changes made to the agreement and the Contract Documents.

14.3 Contractor Default: Failure of the Contractor, which has not been remedied or waived, to perform or otherwise to comply with a material term of the Construction Contract.

14.4 Owner Default: Failure of the Owner, which has not been remedied or waived, to pay the Contractor as required under the Construction Contract or to perform and complete or comply with the other material terms of the Construction Contract.

14.5 Contract Documents: All the documents that comprise the agreement between the Owner and Contractor.

15. If this Bond is issued for an agreement between a contractor and subcontractor, the term Contractor in this Bond shall be deemed to be Subcontractor and the term Owner shall be deemed to be Contractor.

16. Modifications to this Bond are as follows: NONE

**CONSTRUCTION PAYMENT BOND**

**CONSTRUCTION PAYMENT BOND**

**PAYMENT BOND**

**CONTRACTOR** (name and address):

Eagle Elsner, Inc.  
 PO Box 23294  
 Tigard, OR 97281

**SURETY** (name and address of principal place of business):

Western Surety Company  
 12909 SW 68th Parkway, Suite 200  
 Portland, OR 97223

**OWNER** (name and address):

City of Canby, 222 NE 2nd Ave., Canby, OR 97013

**CONSTRUCTION CONTRACT**

Effective Date of the Agreement: March 20, 2019

Amount: Five Hundred Twenty Two Thousand Nine Hundred Forty Nine & 50/100---(\$522,949.50) Dollars

Description (name and location): City of Canby  
 N Maple Street Improvements

**BOND**

Bond Number: 30062422

Date (not earlier than the Effective Date of the Agreement of the Construction Contract): March , 2019

Amount: Five Hundred Twenty Two Thousand Nine Hundred Forty Nine & 50/100---(\$522,949.50) Dollars

Modifications to this Bond Form:  None  See Paragraph 18

Surety and Contractor, intending to be legally bound hereby, subject to the terms set forth below, do each cause this Payment Bond to be duly executed by an authorized officer, agent, or representative.

**CONTRACTOR AS PRINCIPAL**

Eagle Elsner, Inc. \_\_\_\_\_ (seal)

Contractor's Name and Corporate Seal

By: Richard Eagle, Pres  
 Signature

Richard Eagle  
 Print Name

President  
 Title

Attest: Mary Newton  
 Signature

Secretary  
 Title

**SURETY**

Western Surety Company \_\_\_\_\_ (seal)

Surety's Name and Corporate Seal

By: Gloria Bruning  
 Signature (attach power of attorney)

Gloria Bruning  
 Print Name

Attorney-in-fact  
 Title

Attest: [Signature]  
 Signature

Agent-Witness for Surety  
 Title

**Notes: (1) Provide supplemental execution by any additional parties, such as joint venturers. (2) Any singular reference to Contractor, Surety, Owner, or other party shall be considered plural where applicable.**

1. The Contractor and Surety, jointly and severally, bind themselves, their heirs, executors, administrators, successors, and assigns to the Owner to pay for labor, materials, and equipment furnished for use in the performance of the Construction Contract, which is incorporated herein by reference, subject to the following terms.
2. If the Contractor promptly makes payment of all sums due to Claimants, and defends, indemnifies, and holds harmless the Owner from claims, demands, liens, or suits by any person or entity seeking payment for labor, materials, or equipment furnished for use in the performance of the Construction Contract, then the Surety and the Contractor shall have no obligation under this Bond.
3. If there is no Owner Default under the Construction Contract, the Surety's obligation to the Owner under this Bond shall arise after the Owner has promptly notified the Contractor and the Surety (at the address described in Paragraph 13) of claims, demands, liens, or suits against the Owner or the Owner's property by any person or entity seeking payment for labor, materials, or equipment furnished for use in the performance of the Construction Contract, and tendered defense of such claims, demands, liens, or suits to the Contractor and the Surety.
4. When the Owner has satisfied the conditions in Paragraph 3, the Surety shall promptly and at the Surety's expense defend, indemnify, and hold harmless the Owner against a duly tendered claim, demand, lien, or suit.
5. The Surety's obligations to a Claimant under this Bond shall arise after the following:
  - 5.1 Claimants who do not have a direct contract with the Contractor,
    - 5.1.1 have furnished a written notice of non-payment to the Contractor, stating with substantial accuracy the amount claimed and the name of the party to whom the materials were, or equipment was, furnished or supplied or for whom the labor was done or performed, within ninety (90) days after having last performed labor or last furnished materials or equipment included in the Claim; and
    - 5.1.2 have sent a Claim to the Surety (at the address described in Paragraph 13).
  - 5.2 Claimants who are employed by or have a direct contract with the Contractor have sent a Claim to the Surety (at the address described in Paragraph 13).
6. If a notice of non-payment required by Paragraph 5.1.1 is given by the Owner to the Contractor, that is sufficient to satisfy a Claimant's obligation to furnish a written notice of non-payment under Paragraph 5.1.1.
7. When a Claimant has satisfied the conditions of Paragraph 5.1 or 5.2, whichever is applicable, the Surety shall promptly and at the Surety's expense take the following actions:
  - 7.1 Send an answer to the Claimant, with a copy to the Owner, within sixty (60) days after receipt of the Claim, stating the amounts that are undisputed and the basis for challenging any amounts that are disputed; and
  - 7.2 Pay or arrange for payment of any undisputed amounts.
  - 7.3 The Surety's failure to discharge its obligations under Paragraph 7.1 or 7.2 shall not be deemed to constitute a waiver of defenses the Surety or Contractor may have or acquire as to a Claim, except as to undisputed amounts for which the Surety and Claimant have reached agreement. If, however, the Surety fails to discharge its obligations under Paragraph 7.1 or 7.2, the Surety shall indemnify the Claimant for the reasonable attorney's fees the Claimant incurs thereafter to recover any sums found to be due and owing to the Claimant.
8. The Surety's total obligation shall not exceed the amount of this Bond, plus the amount of reasonable attorney's fees provided under Paragraph 7.3, and the amount of this Bond shall be credited for any payments made in good faith by the Surety.
9. Amounts owed by the Owner to the Contractor under the Construction Contract shall be used for the performance of the Construction Contract and to satisfy claims, if any, under any construction performance bond. By the Contractor furnishing and the Owner accepting this Bond, they agree that all funds earned by the Contractor in the performance of the Construction Contract are dedicated to satisfy obligations of the Contractor and Surety under this Bond, subject to the Owner's priority to use the funds for the completion of the work.
10. The Surety shall not be liable to the Owner, Claimants, or others for obligations of the Contractor that are unrelated to the Construction Contract. The Owner shall not be liable for the payment of any costs or expenses of any Claimant under this Bond, and shall have under this Bond no obligation to make payments to or give notice on behalf of Claimants, or otherwise have any obligations to Claimants under this Bond.
11. The Surety hereby waives notice of any change, including changes of time, to the Construction Contract or to related subcontracts, purchase orders, and other obligations.



12. No suit or action shall be commenced by a Claimant under this Bond other than in a court of competent jurisdiction in the state in which the project that is the subject of the Construction Contract is located or after the expiration of one year from the date (1) on which the Claimant sent a Claim to the Surety pursuant to Paragraph 5.1.2 or 5.2, or (2) on which the last labor or service was performed by anyone or the last materials or equipment were furnished by anyone under the Construction Contract, whichever of (1) or (2) first occurs. If the provisions of this paragraph are void or prohibited by law, the minimum period of limitation available to sureties as a defense in the jurisdiction of the suit shall be applicable.
13. Notice and Claims to the Surety, the Owner, or the Contractor shall be mailed or delivered to the address shown on the page on which their signature appears. Actual receipt of notice or Claims, however accomplished, shall be sufficient compliance as of the date received.
14. When this Bond has been furnished to comply with a statutory or other legal requirement in the location where the construction was to be performed, any provision in this Bond conflicting with said statutory or legal requirement shall be deemed deleted herefrom and provisions conforming to such statutory or other legal requirement shall be deemed incorporated herein. When so furnished, the intent is that this Bond shall be construed as a statutory bond and not as a common law bond.
15. Upon requests by any person or entity appearing to be a potential beneficiary of this Bond, the Contractor and Owner shall promptly furnish a copy of this Bond or shall permit a copy to be made.
16. **Definitions**
  - 16.1 **Claim:** A written statement by the Claimant including at a minimum:
    1. The name of the Claimant;
    2. The name of the person for whom the labor was done, or materials or equipment furnished;
    3. A copy of the agreement or purchase order pursuant to which labor, materials, or equipment was furnished for use in the performance of the Construction Contract;
    4. A brief description of the labor, materials, or equipment furnished;
    5. The date on which the Claimant last performed labor or last furnished materials or equipment for use in the performance of the Construction Contract;
    6. The total amount earned by the Claimant for labor, materials, or equipment furnished as of the date of the Claim;
    7. The total amount of previous payments received by the Claimant; and
  - 16.2 **Claimant:** An individual or entity having a direct contract with the Contractor or with a subcontractor of the Contractor to furnish labor, materials, or equipment for use in the performance of the Construction Contract. The term Claimant also includes any individual or entity that has rightfully asserted a claim under an applicable mechanic's lien or similar statute against the real property upon which the Project is located. The intent of this Bond shall be to include without limitation in the terms of "labor, materials, or equipment" that part of the water, gas, power, light, heat, oil, gasoline, telephone service, or rental equipment used in the Construction Contract, architectural and engineering services required for performance of the work of the Contractor and the Contractor's subcontractors, and all other items for which a mechanic's lien may be asserted in the jurisdiction where the labor, materials, or equipment were furnished.
  - 16.3 **Construction Contract:** The agreement between the Owner and Contractor identified on the cover page, including all Contract Documents and all changes made to the agreement and the Contract Documents.
  - 16.4 **Owner Default:** Failure of the Owner, which has not been remedied or waived, to pay the Contractor as required under the Construction Contract or to perform and complete or comply with the other material terms of the Construction Contract.
  - 16.5 **Contract Documents:** All the documents that comprise the agreement between the Owner and Contractor.
17. If this Bond is issued for an agreement between a contractor and subcontractor, the term Contractor in this Bond shall be deemed to be Subcontractor and the term Owner shall be deemed to be Contractor.
18. Modifications to this Bond are as follows: NONE
8. The total amount due and unpaid to the Claimant for labor, materials, or equipment furnished as of the date of the Claim.

# Western Surety Company

## POWER OF ATTORNEY APPOINTING INDIVIDUAL ATTORNEY-IN-FACT

Know All Men By These Presents, That WESTERN SURETY COMPANY, a South Dakota corporation, is a duly organized and existing corporation having its principal office in the City of Sioux Falls, and State of South Dakota, and that it does by virtue of the signature and seal herein affixed hereby make, constitute and appoint

**Philip O Forker, Ray M Paiement, Vicki Mather, Gloria Bruning, Richard W Kowalski, Brent Olson, J Patrick Dooney, Karen A Pierce, Joel Dietzman, Christopher A Reburn, Gail A Price, Tami Jones, Individually**

of Portland, OR, its true and lawful Attorney(s)-in-Fact with full power and authority hereby conferred to sign, seal and execute for and on its behalf bonds, undertakings and other obligatory instruments of similar nature

### - In Unlimited Amounts -

and to bind it thereby as fully and to the same extent as if such instruments were signed by a duly authorized officer of the corporation and all the acts of said Attorney, pursuant to the authority hereby given, are hereby ratified and confirmed.

This Power of Attorney is made and executed pursuant to and by authority of the By-Law printed on the reverse hereof, duly adopted, as indicated, by the shareholders of the corporation.

In Witness Whereof, WESTERN SURETY COMPANY has caused these presents to be signed by its Vice President and its corporate seal to be hereto affixed on this 29th day of November, 2018.



WESTERN SURETY COMPANY

Paul T. Bruflat  
Paul T. Bruflat, Vice President

State of South Dakota }  
County of Minnehaha } ss

On this 29th day of November, 2018, before me personally came Paul T. Bruflat, to me known, who, being by me duly sworn, did depose and say: that he resides in the City of Sioux Falls, State of South Dakota; that he is the Vice President of WESTERN SURETY COMPANY described in and which executed the above instrument; that he knows the seal of said corporation; that the seal affixed to the said instrument is such corporate seal; that it was so affixed pursuant to authority given by the Board of Directors of said corporation and that he signed his name thereto pursuant to like authority, and acknowledges same to be the act and deed of said corporation.

My commission expires

June 23, 2021

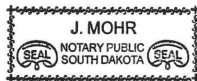

J. Mohr  
J. Mohr, Notary Public

### CERTIFICATE

I, L. Nelson, Assistant Secretary of WESTERN SURETY COMPANY do hereby certify that the Power of Attorney hereinabove set forth is still in force, and further certify that the By-Law of the corporation printed on the reverse hereof is still in force. In testimony whereof I have hereunto subscribed my name and affixed the seal of the said corporation this 20<sup>th</sup> day of March, 2019.



WESTERN SURETY COMPANY

L. Nelson  
L. Nelson, Assistant Secretary

**Authorizing By-Law**

**ADOPTED BY THE SHAREHOLDERS OF WESTERN SURETY COMPANY**

This Power of Attorney is made and executed pursuant to and by authority of the following By-Law duly adopted by the shareholders of the Company.

Section 7. All bonds, policies, undertakings, Powers of Attorney, or other obligations of the corporation shall be executed in the corporate name of the Company by the President, Secretary, and Assistant Secretary, Treasurer, or any Vice President, or by such other officers as the Board of Directors may authorize. The President, any Vice President, Secretary, any Assistant Secretary, or the Treasurer may appoint Attorneys in Fact or agents who shall have authority to issue bonds, policies, or undertakings in the name of the Company. The corporate seal is not necessary for the validity of any bonds, policies, undertakings, Powers of Attorney or other obligations of the corporation. The signature of any such officer and the corporate seal may be printed by facsimile.



EAGLELS-01

RKENNEDY

# CERTIFICATE OF LIABILITY INSURANCE

DATE (MM/DD/YYYY)

3/7/2019

THIS CERTIFICATE IS ISSUED AS A MATTER OF INFORMATION ONLY AND CONFERS NO RIGHTS UPON THE CERTIFICATE HOLDER. THIS CERTIFICATE DOES NOT AFFIRMATIVELY OR NEGATIVELY AMEND, EXTEND OR ALTER THE COVERAGE AFFORDED BY THE POLICIES BELOW. THIS CERTIFICATE OF INSURANCE DOES NOT CONSTITUTE A CONTRACT BETWEEN THE ISSUING INSURER(S), AUTHORIZED REPRESENTATIVE OR PRODUCER, AND THE CERTIFICATE HOLDER.

**IMPORTANT:** If the certificate holder is an **ADDITIONAL INSURED**, the policy(ies) must have **ADDITIONAL INSURED** provisions or be endorsed. If **SUBROGATION IS WAIVED**, subject to the terms and conditions of the policy, certain policies may require an endorsement. A statement on this certificate does not confer rights to the certificate holder in lieu of such endorsement(s).

PRODUCER Anchor Insurance & Surety, Inc. 1201 SW 12th Ave. Suite 500 Portland, OR 97205	CONTACT NAME: <b>Kimberly Lee</b>	
	PHONE (A/C, No, Ext): <b>(503) 224-2500</b>	FAX (A/C, No): <b>(503) 224-9830</b>
E-MAIL ADDRESS: <b>klee@anchorias.com</b>		
INSURER(S) AFFORDING COVERAGE		NAIC #
INSURER A : <b>Charter Oak Fire Ins. Co.</b>		<b>25615</b>
INSURER B : <b>Travelers Property Casualty Co. of America</b>		<b>25674</b>
INSURER C : <b>Travelers Casualty Insurance Co. of America</b>		
INSURER D : <b>SAIF Corporation</b>		<b>36196</b>
INSURER E : <b>Travelers Indemnity Co.</b>		<b>25666</b>
INSURER F :		

INSURED  
**Eagle Elsner, Inc.**  
P. O. Box 23294  
Tigard, OR 97281

**COVERAGES**                      **CERTIFICATE NUMBER:**                      **REVISION NUMBER:**

THIS IS TO CERTIFY THAT THE POLICIES OF INSURANCE LISTED BELOW HAVE BEEN ISSUED TO THE INSURED NAMED ABOVE FOR THE POLICY PERIOD INDICATED. NOTWITHSTANDING ANY REQUIREMENT, TERM OR CONDITION OF ANY CONTRACT OR OTHER DOCUMENT WITH RESPECT TO WHICH THIS CERTIFICATE MAY BE ISSUED OR MAY PERTAIN, THE INSURANCE AFFORDED BY THE POLICIES DESCRIBED HEREIN IS SUBJECT TO ALL THE TERMS, EXCLUSIONS AND CONDITIONS OF SUCH POLICIES. LIMITS SHOWN MAY HAVE BEEN REDUCED BY PAID CLAIMS.

INSR LTR	TYPE OF INSURANCE	ADDITIONAL SUBROGATION WAIVED	POLICY NUMBER	POLICY EFF (MM/DD/YYYY)	POLICY EXP (MM/DD/YYYY)	LIMITS
A	<input checked="" type="checkbox"/> COMMERCIAL GENERAL LIABILITY	<input checked="" type="checkbox"/>	CO-1019R236-COF-18	6/1/2018	6/1/2019	EACH OCCURRENCE \$ 1,000,000
	<input type="checkbox"/> CLAIMS-MADE <input checked="" type="checkbox"/> OCCUR					DAMAGE TO RENTED PREMISES (Ea occurrence) \$ 300,000
	<input checked="" type="checkbox"/> XC&U COVERAGE					MED EXP (Any one person) \$ 10,000
	<input checked="" type="checkbox"/> CONTRACTUAL LIAB					PERSONAL & ADV INJURY \$ 1,000,000
GEN'L AGGREGATE LIMIT APPLIES PER:						GENERAL AGGREGATE \$ 2,000,000
POLICY <input checked="" type="checkbox"/> PROJECT <input type="checkbox"/> LOC						PRODUCTS - COM/OP AGG \$ 2,000,000
OTHER: <b>WA STOP GAP</b>						<b>POLLUTION</b> \$ 1,000,000
B	AUTOMOBILE LIABILITY	<input checked="" type="checkbox"/>	810-1019R236-TIL-18	6/1/2018	6/1/2019	COMBINED SINGLE LIMIT (Ea accident) \$ 1,000,000
	<input checked="" type="checkbox"/> ANY AUTO OWNED AUTOS ONLY					BODILY INJURY (Per person) \$
	<input type="checkbox"/> HIRE SCHEDULED AUTOS					BODILY INJURY (Per accident) \$
	<input type="checkbox"/> HIRED NON-OWNED AUTOS ONLY					PROPERTY DAMAGE (Per accident) \$
AUTO POLLUTION \$ 1,000,000						
C	<input checked="" type="checkbox"/> UMBRELLA LIAB <input checked="" type="checkbox"/> OCCUR	<input checked="" type="checkbox"/>	CUP-5J064957-18-26	6/1/2018	6/1/2019	EACH OCCURRENCE \$ 1,000,000
	<input type="checkbox"/> EXCESS LIAB <input type="checkbox"/> CLAIMS-MADE					AGGREGATE \$ 1,000,000
	DED <input checked="" type="checkbox"/> RETENTION \$ 10,000					
D	WORKERS COMPENSATION AND EMPLOYERS' LIABILITY	<input type="checkbox"/>	810540	10/1/2018	10/1/2019	PER STATUTE <input type="checkbox"/> OTH-ER <input type="checkbox"/>
	ANY PROPRIETOR/PARTNER/EXECUTIVE OFFICER/MEMBER EXCLUDED? (Mandatory in NH)					E.L. EACH ACCIDENT \$ 500,000
	If yes, describe under DESCRIPTION OF OPERATIONS below					E.L. DISEASE - EA EMPLOYEE \$ 500,000
						E.L. DISEASE - POLICY LIMIT \$ 500,000
E	INSTALLATION FLOATER		8449L841-TIA-18	6/1/2018	6/1/2019	ANY ONE LOCATION 1,000,000

DESCRIPTION OF OPERATIONS / LOCATIONS / VEHICLES (ACORD 101, Additional Remarks Schedule, may be attached if more space is required)  
**N Maple Street Improvements**  
 Certificate holder and all other entities are additional insureds when specified by written contract. Coverage is primary & non-contributory and includes waiver of subrogation when required by written contract. All subject to the terms, conditions and exclusions of the policies. Endorsements attached: CG D2 46 08 05, CG D3 16 11 11, CG D2 11 01 04, CA T3 53 02 15, WC000313.  
 Umbrella Excess Liability goes over General Liability, Auto and Employers Liability.  
 Additional Insured: Owner and Curran-McLeod, Inc., Engineer as required by written contract or agreement and subject to the terms, conditions and exclusions of the policies referenced.

<b>CERTIFICATE HOLDER</b>  City of Canby P O Box 930 Canby, OR 97013	<b>CANCELLATION</b>  SHOULD ANY OF THE ABOVE DESCRIBED POLICIES BE CANCELLED BEFORE THE EXPIRATION DATE THEREOF, NOTICE WILL BE DELIVERED IN ACCORDANCE WITH THE POLICY PROVISIONS.
	AUTHORIZED REPRESENTATIVE  

**THIS ENDORSEMENT CHANGES THE POLICY. PLEASE READ IT CAREFULLY**

## **BLANKET ADDITIONAL INSURED (CONTRACTORS)**

This endorsement modifies insurance provided under the following:

### **COMMERCIAL GENERAL LIABILITY COVERAGE PART**

1. WHO IS AN INSURED – (Section II) is amended to include any person or organization that you agree in a "written contract requiring insurance" to include as an additional insured on this Coverage Part, but:
  - a) Only with respect to liability for "bodily injury", "property damage" or "personal injury"; and
  - b) If, and only to the extent that, the injury or damage is caused by acts or omissions of you or your subcontractor in the performance of "your work" to which the "written contract requiring insurance" applies. The person or organization does not qualify as an additional insured with respect to the independent acts or omissions of such person or organization.
2. The insurance provided to the additional insured by this endorsement is limited as follows:
  - a) In the event that the Limits of Insurance of this Coverage Part shown in the Declarations exceed the limits of liability required by the "written contract requiring insurance", the insurance provided to the additional insured shall be limited to the limits of liability required by that "written contract requiring insurance". This endorsement shall not increase the limits of insurance described in Section III – Limits Of Insurance.
  - b) The insurance provided to the additional insured does not apply to "bodily injury", "property damage" or "personal injury" arising out of the rendering of, or failure to render, any professional architectural, engineering or surveying services, including:
    - i. The preparing, approving, or failing to prepare or approve, maps, shop drawings, opinions, reports, surveys, field orders or change orders, or the preparing, approving, or failing to prepare or approve, drawings and specifications; and
    - ii. Supervisory, inspection, architectural or engineering activities.
3. The insurance provided to the additional insured by this endorsement is excess over any valid and collectible "other insurance", whether primary, excess, contingent or on any other basis, that is available to the additional insured for a loss we cover under this endorsement. However, if the "written contract requiring insurance" specifically requires that this insurance apply on a primary basis or a primary and non-contributory basis, this insurance is primary to "other insurance" available to the additional insured which covers that person or organization as a named insured for such loss, and we will not share with that "other insurance". But the insurance provided to the additional insured by this endorsement still is excess over any valid and collectible "other insurance", whether primary, excess, contingent or on any other basis, that is available to the additional insured when that person or organization is an additional insured under such "other insurance".
4. As a condition of coverage provided to the additional insured by this endorsement:
  - a) The additional insured must give us written notice as soon as practicable of an "occurrence" or an offense which may result in a claim. To the extent possible, such notice should include:
5. The insurance provided to the additional insured does not apply to "bodily injury" or "property damage" caused by "your work" and included in the "products-completed operations hazard" unless the "written contract requiring insurance" specifically requires you to provide such coverage for that additional insured, and then the insurance provided to the additional insured applies only to such "bodily injury" or "property damage" that occurs before the end of the period of time for which the "written contract requiring insurance" requires you to provide such coverage or the end of the policy period, whichever is earlier.

## COMMERCIAL GENERAL LIABILITY

- i. How, when and where the "occurrence" or offense took place;
  - ii. The names and addresses of any injured persons and witnesses; and
  - iii. The nature and location of any injury or damage arising out of the "occurrence" or offense.
- b) If a claim is made or "suit" is brought against the additional insured, the additional insured must:
- i. Immediately record the specifics of the claim or "suit" and the date received; and
  - ii. Notify us as soon as practicable.
- The additional insured must see to it that we receive written notice of the claim or "suit" as soon as practicable.
- c) The additional Insured must immediately send us copies of all legal papers received in connection with the claim or "suit", cooperate with us in the investigation or settlement of the claim or defense against the "suit", and otherwise comply with all policy conditions.
- d) The additional insured must tender the defense and indemnity of any claim or "suit" to

any provider of "other insurance" which would cover the additional insured for a loss we cover under this endorsement. However, this condition does not affect whether the insurance provided to the additional insured by this endorsement is primary to "other insurance" available to the additional insured which covers that person or organization as a named insured as described in paragraph 3. above.

5. The following definition is added to SECTION V. – DEFINITIONS:

"Written contract requiring insurance" means that part of any written contract or agreement under which you are required to include a person or organization as an additional insured on this Coverage Part, provided that the "bodily injury" and "property damage" occurs and the "personal injury" is caused by an offense committed:

- a. After the signing and execution of the contract or agreement by you;
- b. While that part of the contract or agreement is in effect; and
- c. Before the end of the policy period.

**THIS ENDORSEMENT CHANGES THE POLICY. PLEASE READ IT CAREFULLY.**

## **CONTRACTORS XTEND ENDORSEMENT**

This endorsement modifies insurance provided under the following:

### **COMMERCIAL GENERAL LIABILITY COVERAGE PART**

**GENERAL DESCRIPTION OF COVERAGE** – This endorsement broadens coverage. However, coverage for any injury, damage or medical expenses described in any of the provisions of this endorsement may be excluded or limited by another endorsement to this Coverage Part, and these coverage broadening provisions do not apply to the extent that coverage is excluded or limited by such an endorsement. The following listing is a general coverage description only. Limitations and exclusions may apply to these coverages. Read all the provisions of this endorsement and the rest of your policy carefully to determine rights, duties, and what is and is not covered.

- |  |   |
|--|---|
| <ul style="list-style-type: none"> <li>A. Aircraft Chartered With Pilot</li> <li>B. Damage To Premises Rented To You</li> <li>C. Increased Supplementary Payments</li> <li>D. Incidental Medical Malpractice</li> <li>E. Who Is An Insured – Newly Acquired Or Formed Organizations</li> <li>F. Who Is An Insured – Broadened Named Insured – Unnamed Subsidiaries</li> <li>G. Blanket Additional Insured – Owners, Managers Or Lessors Of Premises</li> </ul> | <ul style="list-style-type: none"> <li>H. Blanket Additional Insured – Lessors Of Leased Equipment</li> <li>I. Blanket Additional Insured – States Or Political Subdivisions – Permits</li> <li>J. Knowledge And Notice Of Occurrence Or Offense</li> <li>K. Unintentional Omission</li> <li>L. Blanket Waiver Of Subrogation</li> <li>M. Amended Bodily Injury Definition</li> <li>N. Contractual Liability – Railroads</li> </ul> |
|--|---|

### **PROVISIONS**

#### **A. AIRCRAFT CHARTERED WITH PILOT**

The following is added to Exclusion **g.**, **Aircraft, Auto Or Watercraft**, in Paragraph 2. of **SECTION I – COVERAGES – COVERAGE A BODILY INJURY AND PROPERTY DAMAGE LIABILITY**:

This exclusion does not apply to an aircraft that is:

- (a) Chartered with a pilot to any insured;
- (b) Not owned by any insured; and
- (c) Not being used to carry any person or property for a charge.

#### **B. DAMAGE TO PREMISES RENTED TO YOU**

1. The first paragraph of the exceptions in Exclusion **j.**, **Damage To Property**, in Paragraph 2. of **SECTION I – COVERAGES – COVERAGE A BODILY INJURY AND PROPERTY DAMAGE LIABILITY** is deleted.
2. The following replaces the last paragraph of Paragraph 2., **Exclusions**, of **SECTION I – COVERAGES – COVERAGE A. BODILY**

### **INJURY AND PROPERTY DAMAGE LIABILITY:**

Exclusions **c.** and **g.** through **n.** do not apply to "premises damage". Exclusion **f.(1)(a)** does not apply to "premises damage" caused by:

- a. Fire;
- b. Explosion;
- c. Lightning;
- d. Smoke resulting from such fire, explosion, or lightning; or
- e. Water;

unless Exclusion **f.** of Section **I – Coverage A – Bodily Injury And Property Damage Liability** is replaced by another endorsement to this Coverage Part that has Exclusion – All Pollution Injury Or Damage or Total Pollution Exclusion in its title.

A separate limit of insurance applies to "premises damage" as described in Paragraph 6. of **SECTION III – LIMITS OF INSURANCE**.

## COMMERCIAL GENERAL LIABILITY

### 3. The following replaces Paragraph 6. of **SECTION III – LIMITS OF INSURANCE:**

Subject to 5. above, the Damage To Premises Rented To You Limit is the most we will pay under Coverage A for damages because of "premises damage" to any one premises. The Damage To Premises Rented To You Limit will apply to all "property damage" proximately caused by the same "occurrence", whether such damage results from: fire; explosion; lightning; smoke resulting from such fire, explosion, or lightning; or water; or any combination of any of these causes.

The Damage To Premises Rented To You Limit will be:

- a. The amount shown for the Damage To Premises Rented To You Limit on the Declarations of this Coverage Part; or
  - b. \$300,000 if no amount is shown for the Damage To Premises Rented To You Limit on the Declarations of this Coverage Part.
4. The following replaces Paragraph a. of the definition of "insured contract" in the **DEFINITIONS** Section:
- a. A contract for a lease of premises. However, that portion of the contract for a lease of premises that indemnifies any person or organization for "premises damage" is not an "insured contract";
5. The following is added to the **DEFINITIONS** Section:
- "Premises damage" means "property damage" to:
- a. Any premises while rented to you or temporarily occupied by you with permission of the owner; or
  - b. The contents of any premises while such premises is rented to you, if you rent such premises for a period of seven or fewer consecutive days.
6. The following replaces Paragraph 4.b.(1)(b) of **SECTION IV – COMMERCIAL GENERAL LIABILITY CONDITIONS:**
- (b) That is insurance for "premises damage"; or
7. Paragraph 4.b.(1)(c) of **SECTION IV – COMMERCIAL GENERAL LIABILITY CONDITIONS** is deleted.

### C. INCREASED SUPPLEMENTARY PAYMENTS

1. The following replaces Paragraph 1.b. of **SUPPLEMENTARY PAYMENTS – COVERAGES A AND B** of **SECTION I – COVERAGE:**
  - b. Up to \$2,500 for the cost of bail bonds required because of accidents or traffic law violations arising out of the use of any vehicle to which the Bodily Injury Liability Coverage applies. We do not have to furnish these bonds.
2. The following replaces Paragraph 1.d. of **SUPPLEMENTARY PAYMENTS – COVERAGES A AND B** of **SECTION I – COVERAGE:**
  - d. All reasonable expenses incurred by the insured at our request to assist us in the investigation or defense of the claim or "suit", including actual loss of earnings up to \$500 a day because of time off from work.

### D. INCIDENTAL MEDICAL MALPRACTICE

1. The following is added to the definition of "occurrence" in the **DEFINITIONS** Section:

"Occurrence" also means an act or omission committed in providing or failing to provide "incidental medical services", first aid or "Good Samaritan services" to a person.
2. The following is added to Paragraph 2.a.(1) of **SECTION II – WHO IS AN INSURED:**

Paragraph (1)(d) above does not apply to "bodily injury" arising out of providing or failing to provide:

  - (i) "Incidental medical services" by any of your "employees" who is a nurse practitioner, registered nurse, licensed practical nurse, nurse assistant, emergency medical technician or paramedic; or
  - (ii) First aid or "Good Samaritan services" by any of your "employees" or "volunteer workers", other than an employed or volunteer doctor. Any such "employees" or "volunteer workers" providing or failing to provide first aid or "Good Samaritan services" during their work hours for you will be deemed to be acting within the scope of their employment by you or performing duties related to the conduct of your business.



3. The following is added to Paragraph 5. of **SECTION III – LIMITS OF INSURANCE:**

For the purposes of determining the applicable Each Occurrence Limit, all related acts or omissions committed in providing or failing to provide "incidental medical services", first aid or "Good Samaritan services" to any one person will be deemed to be one "occurrence".

4. The following exclusion is added to Paragraph 2., **Exclusions**, of **SECTION I – COVERAGES – COVERAGE A BODILY INJURY AND PROPERTY DAMAGE LIABILITY:**

**Sale Of Pharmaceuticals**

"Bodily injury" or "property damage" arising out of the willful violation of a penal statute or ordinance relating to the sale of pharmaceuticals committed by, or with the knowledge or consent of, the insured.

5. The following is added to the **DEFINITIONS** Section:

"Incidental medical services" means:

- a. Medical, surgical, dental, laboratory, x-ray or nursing service or treatment, advice or instruction, or the related furnishing of food or beverages; or
- b. The furnishing or dispensing of drugs or medical, dental, or surgical supplies or appliances.

"Good Samaritan services" means any emergency medical services for which no compensation is demanded or received.

6. The following is added to Paragraph 4.b., **Excess Insurance**, of **SECTION IV – COMMERCIAL GENERAL LIABILITY CONDITIONS:**

The insurance is excess over any valid and collectible other insurance available to the insured, whether primary, excess, contingent or on any other basis, that is available to any of your "employees" or "volunteer workers" for "bodily injury" that arises out of providing or failing to provide "incidental medical services", first aid or "Good Samaritan services" to any person to the extent not subject to Paragraph 2.a.(1) of Section II – Who Is An Insured.

- E. WHO IS AN INSURED – NEWLY ACQUIRED OR FORMED ORGANIZATIONS**

The following replaces Paragraph 4. of **SECTION II – WHO IS AN INSURED:**

4. Any organization you newly acquire or form, other than a partnership, joint venture or limited liability company, of which you are the sole owner or in which you maintain the majority ownership interest, will qualify as a Named Insured if there is no other insurance which provides similar coverage to that organization. However:

- a. Coverage under this provision is afforded only:

- (1) Until the 180th day after you acquire or form the organization or the end of the policy period, whichever is earlier, if you do not report such organization in writing to us within 180 days after you acquire or form it; or

- (2) Until the end of the policy period, when that date is later than 180 days after you acquire or form such organization, if you report such organization in writing to us within 180 days after you acquire or form it, and we agree in writing that it will continue to be a Named Insured until the end of the policy period;

- b. Coverage A does not apply to "bodily injury" or "property damage" that occurred before you acquired or formed the organization; and

- c. Coverage B does not apply to "personal injury" or "advertising injury" arising out of an offense committed before you acquired or formed the organization.

- F. WHO IS AN INSURED – BROADENED NAMED INSURED – UNNAMED SUBSIDIARIES**

The following is added to **SECTION II – WHO IS AN INSURED:**

Any of your subsidiaries, other than a partnership, joint venture or limited liability company, that is not shown as a Named Insured in the Declarations is a Named Insured if you maintain an ownership interest of more than 50% in such subsidiary on the first day of the policy period.

No such subsidiary is an insured for "bodily injury" or "property damage" that occurred, or "personal injury" or "advertising injury" caused by an offense committed after the date, if any, during the policy period, that you no longer maintain an ownership interest of more than 50% in such subsidiary.

## COMMERCIAL GENERAL LIABILITY

### G. BLANKET ADDITIONAL INSURED – OWNERS, MANAGERS OR LESSORS OF PREMISES

The following is added to **SECTION II – WHO IS AN INSURED**:

Any person or organization that is a premises owner, manager or lessor and that you have agreed in a written contract or agreement to include as an additional insured on this Coverage Part is an insured, but only with respect to liability for "bodily injury", "property damage", "personal injury" or "advertising injury" that:

- a. Is "bodily injury" or "property damage" that occurs, or is "personal injury" or "advertising injury" caused by an offense that is committed, subsequent to the execution of that contract or agreement; and
- b. Arises out of the ownership, maintenance or use of that part of any premises leased to you.

The insurance provided to such premises owner, manager or lessor is subject to the following provisions:

- a. The limits of insurance provided to such premises owner, manager or lessor will be the minimum limits which you agreed to provide in the written contract or agreement, or the limits shown on the Declarations, whichever are less.
- b. The insurance provided to such premises owner, manager or lessor does not apply to:
  - (1) Any "bodily injury" or "property damage" that occurs, or "personal injury" or "advertising injury" caused by an offense that is committed, after you cease to be a tenant in that premises; or
  - (2) Structural alterations, new construction or demolition operations performed by or on behalf of such premises owner, lessor or manager.
- c. The insurance provided to such premises owner, manager or lessor is excess over any valid and collectible other insurance available to such premises owner, manager or lessor, whether primary, excess, contingent or on any other basis, unless you have agreed in the written contract or agreement that this insurance must be primary to, or non-contributory with, such other insurance, in which case this insurance will be primary to, and non-contributory with, such other insurance.

### H. BLANKET ADDITIONAL INSURED – LESSORS OF LEASED EQUIPMENT

The following is added to **SECTION II – WHO IS AN INSURED**:

Any person or organization that is an equipment lessor and that you have agreed in a written contract or agreement to include as an insured on this Coverage Part is an insured, but only with respect to liability for "bodily injury", "property damage", "personal injury" or "advertising injury" that:

- a. Is "bodily injury" or "property damage" that occurs, or is "personal injury" or "advertising injury" caused by an offense that is committed, subsequent to the execution of that contract or agreement; and
- b. Is caused, in whole or in part, by your acts or omissions in the maintenance, operation or use of equipment leased to you by such equipment lessor.

The insurance provided to such equipment lessor is subject to the following provisions:

- a. The limits of insurance provided to such equipment lessor will be the minimum limits which you agreed to provide in the written contract or agreement, or the limits shown on the Declarations, whichever are less.
  - b. The insurance provided to such equipment lessor does not apply to any "bodily injury" or "property damage" that occurs, or "personal injury" or "advertising injury" caused by an offense that is committed, after the equipment lease expires.
  - c. The insurance provided to such equipment lessor is excess over any valid and collectible other insurance available to such equipment lessor, whether primary, excess, contingent or on any other basis, unless you have agreed in the written contract or agreement that this insurance must be primary to, or non-contributory with, such other insurance, in which case this insurance will be primary to, and non-contributory with, such other insurance.
- ### I. BLANKET ADDITIONAL INSURED – STATES OR POLITICAL SUBDIVISIONS – PERMITS

The following is added to **SECTION II – WHO IS AN INSURED**:

Any state or political subdivision that has issued a permit in connection with operations performed by you or on your behalf and that you are required

## COMMERCIAL GENERAL LIABILITY

by any ordinance, law or building code to include as an additional insured on this Coverage Part is an insured, but only with respect to liability for "bodily injury", "property damage", "personal injury" or "advertising injury" arising out of such operations.

The insurance provided to such state or political subdivision does not apply to:

- a. Any "bodily injury," "property damage," "personal injury" or "advertising injury" arising out of operations performed for that state or political subdivision; or
- b. Any "bodily injury" or "property damage" included in the "products-completed operations hazard".

### J. KNOWLEDGE AND NOTICE OF OCCURRENCE OR OFFENSE

The following is added to Paragraph 2., **Duties In The Event of Occurrence, Offense, Claim or Suit**, of **SECTION IV – COMMERCIAL GENERAL LIABILITY CONDITIONS**:

- e. The following provisions apply to Paragraph a. above, but only for the purposes of the insurance provided under this Coverage Part to you or any insured listed in Paragraph 1. or 2. of Section II – Who Is An Insured:
  - (1) Notice to us of such "occurrence" or offense must be given as soon as practicable only after the "occurrence" or offense is known by you (if you are an individual), any of your partners or members who is an individual (if you are a partnership or joint venture), any of your managers who is an individual (if you are a limited liability company), any of your "executive officers" or directors (if you are an organization other than a partnership, joint venture or limited liability company) or any "employee" authorized by you to give notice of an "occurrence" or offense.
  - (2) If you are a partnership, joint venture or limited liability company, and none of your partners, joint venture members or managers are individuals, notice to us of such "occurrence" or offense must be given as soon as practicable only after the "occurrence" or offense is known by:
    - (a) Any individual who is:
      - (i) A partner or member of any partnership or joint venture;

- (ii) A manager of any limited liability company; or

- (iii) An executive officer or director of any other organization;

that is your partner, joint venture member or manager; or

- (b) Any "employee" authorized by such partnership, joint venture, limited liability company or other organization to give notice of an "occurrence" or offense.

- (3) Notice to us of such "occurrence" or of an offense will be deemed to be given as soon as practicable if it is given in good faith as soon as practicable to your workers' compensation insurer. This applies only if you subsequently give notice to us of the "occurrence" or offense as soon as practicable after any of the persons described in Paragraphs e. (1) or (2) above discovers that the "occurrence" or offense may result in sums to which the insurance provided under this Coverage Part may apply.

However, if this Coverage Part includes an endorsement that provides limited coverage for "bodily injury" or "property damage" or pollution costs arising out of a discharge, release or escape of "pollutants" which contains a requirement that the discharge, release or escape of "pollutants" must be reported to us within a specific number of days after its abrupt commencement, this Paragraph e. does not affect that requirement.

### K. UNINTENTIONAL OMISSION

The following is added to Paragraph 6., **Representations**, of **SECTION IV – COMMERCIAL GENERAL LIABILITY CONDITIONS**:

The unintentional omission of, or unintentional error in, any information provided by you which we relied upon in issuing this policy will not prejudice your rights under this insurance. However, this provision does not affect our right to collect additional premium or to exercise our rights of cancellation or nonrenewal in accordance with applicable insurance laws or regulations.

### L. BLANKET WAIVER OF SUBROGATION

The following is added to Paragraph 8., **Transfer Of Rights Of Recovery Against Others To Us**, of **SECTION IV – COMMERCIAL GENERAL LIABILITY CONDITIONS**:

## COMMERCIAL GENERAL LIABILITY

If the insured has agreed in a contract or agreement to waive that insured's right of recovery against any person or organization, we waive our right of recovery against such person or organization, but only for payments we make because of:

- a. "Bodily injury" or "property damage" that occurs; or
- b. "Personal injury" or "advertising injury" caused by an offense that is committed;

subsequent to the execution of that contract or agreement.

### M. AMENDED BODILY INJURY DEFINITION

The following replaces the definition of "bodily injury" in the **DEFINITIONS** Section:

3. "Bodily injury" means bodily injury, mental anguish, mental injury, shock, fright, disability, humiliation, sickness or disease sustained by a person, including death resulting from any of these at any time.

### N. CONTRACTUAL LIABILITY – RAILROADS

1. The following replaces Paragraph c. of the definition of "insured contract" in the **DEFINITIONS** Section:
  - c. Any easement or license agreement;
2. Paragraph f.(1) of the definition of "insured contract" in the **DEFINITIONS** Section is deleted.



This document has important legal consequences; consultation with an attorney is encouraged with respect to its use or modification. This document should be adapted to the particular circumstances of the contemplated Project and the controlling Laws and Regulations.

## STANDARD GENERAL CONDITIONS OF THE CONSTRUCTION CONTRACT

Prepared by



Issued and Published Jointly by



These General Conditions have been prepared for use with the Agreement Between Owner and Contractor for Construction Contract (EJCDC® C-520, Stipulated Sum, or C-525, Cost-Plus, 2013 Editions). Their provisions are interrelated and a change in one may necessitate a change in the other.

To prepare supplementary conditions that are coordinated with the General Conditions, use EJCDC's Guide to the Preparation of Supplementary Conditions (EJCDC® C-800, 2013 Edition). The full EJCDC Construction series of documents is discussed in the Commentary on the 2013 EJCDC Construction Documents (EJCDC® C-001, 2013 Edition).

Copyright © 2013:

National Society of Professional Engineers  
1420 King Street, Alexandria, VA 22314-2794  
(703) 684-2882  
[www.nspe.org](http://www.nspe.org)

American Council of Engineering Companies  
1015 15th Street N.W., Washington, DC 20005  
(202) 347-7474  
[www.acec.org](http://www.acec.org)

American Society of Civil Engineers  
1801 Alexander Bell Drive, Reston, VA 20191-4400  
(800) 548-2723  
[www.asce.org](http://www.asce.org)

The copyright for this document is owned jointly by the three sponsoring organizations listed above. The National Society of Professional Engineers is the Copyright Administrator for the EJCDC documents; please direct all inquiries regarding EJCDC copyrights to NSPE.

NOTE: EJCDC publications may be purchased at [www.ejcdc.org](http://www.ejcdc.org), or from any of the sponsoring organizations above.

**STANDARD GENERAL CONDITIONS OF THE  
CONSTRUCTION CONTRACT**

**TABLE OF CONTENTS**

	Page
Article 1 – Definitions and Terminology .....	1
1.01 Defined Terms .....	1
1.02 Terminology.....	5
Article 2 – Preliminary Matters.....	6
2.01 Delivery of Bonds and Evidence of Insurance .....	6
2.02 Copies of Documents.....	6
2.03 Before Starting Construction.....	6
2.04 Preconstruction Conference; Designation of Authorized Representatives .....	7
2.05 Initial Acceptance of Schedules.....	7
2.06 Electronic Transmittals.....	7
Article 3 – Documents: Intent, Requirements, Reuse .....	8
3.01 Intent.....	8
3.02 Reference Standards .....	8
3.03 Reporting and Resolving Discrepancies.....	8
3.04 Requirements of the Contract Documents .....	9
3.05 Reuse of Documents.....	10
Article 4 – Commencement and Progress of the Work.....	10
4.01 Commencement of Contract Times; Notice to Proceed .....	10
4.02 Starting the Work .....	10
4.03 Reference Points .....	10
4.04 Progress Schedule .....	10
4.05 Delays in Contractor’s Progress.....	11
Article 5 – Availability of Lands; Subsurface and Physical Conditions; Hazardous Environmental Conditions .....	12
5.01 Availability of Lands.....	12
5.02 Use of Site and Other Areas .....	12
5.03 Subsurface and Physical Conditions .....	13
5.04 Differing Subsurface or Physical Conditions.....	14
5.05 Underground Facilities .....	15
5.06 Hazardous Environmental Conditions at Site.....	17
Article 6 – Bonds and Insurance .....	19
6.01 Performance, Payment, and Other Bonds .....	19
6.02 Insurance—General Provisions .....	19
6.03 Contractor’s Insurance .....	20
6.04 Owner’s Liability Insurance .....	23
6.05 Property Insurance .....	23
6.06 Waiver of Rights .....	25
6.07 Receipt and Application of Property Insurance Proceeds.....	25
Article 7 – Contractor’s Responsibilities .....	26
7.01 Supervision and Superintendence.....	26
7.02 Labor; Working Hours.....	26
7.03 Services, Materials, and Equipment.....	26
7.04 “Or Equals” .....	27
7.05 Substitutes.....	28
7.06 Concerning Subcontractors, Suppliers, and Others .....	29
7.07 Patent Fees and Royalties .....	31
7.08 Permits .....	31
7.09 Taxes.....	32
7.10 Laws and Regulations .....	32
7.11 Record Documents.....	32
7.12 Safety and Protection .....	32
7.13 Safety Representative .....	33
7.14 Hazard Communication Programs.....	33
7.15 Emergencies .....	34
7.16 Shop Drawings, Samples, and Other Submittals .....	34
7.17 Contractor’s General Warranty and Guarantee.....	36
7.18 Indemnification .....	37
7.19 Delegation of Professional Design Services.....	37
Article 8 – Other Work at the Site .....	38
8.01 Other Work.....	38
8.02 Coordination.....	39
8.03 Legal Relationships .....	39

Article 9 – Owner’s Responsibilities.....	40
9.01 Communications to Contractor.....	40
9.02 Replacement of Engineer.....	40
9.03 Furnish Data.....	40
9.04 Pay When Due.....	40
9.05 Lands and Easements; Reports, Tests, and Drawings.....	40
9.06 Insurance.....	40
9.07 Change Orders.....	40
9.08 Inspections, Tests, and Approvals.....	41
9.09 Limitations on Owner’s Responsibilities.....	41
9.10 Undisclosed Hazardous Environmental Condition.....	41
9.11 Evidence of Financial Arrangements.....	41
9.12 Safety Programs.....	41
Article 10 – Engineer’s Status During Construction.....	41
10.01 Owner’s Representative.....	41
10.02 Visits to Site.....	41
10.03 Project Representative.....	42
10.04 Rejecting Defective Work.....	42
10.05 Shop Drawings, Change Orders and Payments.....	42
10.06 Determinations for Unit Price Work.....	42
10.07 Decisions on Requirements of Contract Documents and Acceptability of Work.....	42
10.08 Limitations on Engineer’s Authority and Responsibilities.....	42
10.09 Compliance with Safety Program.....	43
Article 11 – Amending the Contract Documents; Changes in the Work.....	43
11.01 Amending and Supplementing Contract Documents.....	43
11.02 Owner-Authorized Changes in the Work.....	44
11.03 Unauthorized Changes in the Work.....	44
11.04 Change of Contract Price.....	44
11.05 Change of Contract Times.....	45
11.06 Change Proposals.....	45
11.07 Execution of Change Orders.....	46
11.08 Notification to Surety.....	47
Article 12 – Claims.....	47

12.01 Claims.....	47
Article 13 – Cost of the Work; Allowances; Unit Price Work.....	48
13.01 Cost of the Work.....	48
13.02 Allowances.....	50
13.03 Unit Price Work.....	51
Article 14 – Tests and Inspections; Correction, Removal or Acceptance of Defective Work.....	52
14.01 Access to Work.....	52
14.02 Tests, Inspections, and Approvals.....	52
14.03 Defective Work.....	53
14.04 Acceptance of Defective Work.....	53
14.05 Uncovering Work.....	53
14.06 Owner May Stop the Work.....	54
14.07 Owner May Correct Defective Work.....	54
Article 15 – Payments to Contractor; Set-Offs; Completion; Correction Period.....	55
15.01 Progress Payments.....	55
15.02 Contractor’s Warranty of Title.....	58
15.03 Substantial Completion.....	58
15.04 Partial Use or Occupancy.....	59
15.05 Final Inspection.....	59
15.06 Final Payment.....	59
15.07 Waiver of Claims.....	61
15.08 Correction Period.....	61
Article 16 – Suspension of Work and Termination.....	62
16.01 Owner May Suspend Work.....	62
16.02 Owner May Terminate for Cause.....	62
16.03 Owner May Terminate For Convenience.....	63
16.04 Contractor May Stop Work or Terminate.....	63
Article 17 – Final Resolution of Disputes.....	64
17.01 Methods and Procedures.....	64
Article 18 – Miscellaneous.....	64
18.01 Giving Notice.....	64
18.02 Computation of Times.....	64
18.03 Cumulative Remedies.....	64



37. *Site*—Lands or areas indicated in the Contract Documents as being furnished by Owner upon which the Work is to be performed, including rights-of-way and easements, and such other lands furnished by Owner which are designated for the use of Contractor.
38. *Specifications*—The part of the Contract that consists of written requirements for materials, equipment, systems, standards, and workmanship as applied to the Work, and certain administrative requirements and procedural matters applicable to the Work.
39. *Subcontractor*—An individual or entity having a direct contract with Contractor or with any other Subcontractor for the performance of a part of the Work.
40. *Substantial Completion*—The time at which the Work (or a specified part thereof) has progressed to the point where, in the opinion of Engineer, the Work (or a specified part thereof) is sufficiently complete, in accordance with the Contract Documents, so that the Work (or a specified part thereof) can be utilized for the purposes for which it is intended. The terms “substantially complete” and “substantially completed” as applied to all or part of the Work refer to Substantial Completion thereof.
41. *Successful Bidder*—The Bidder whose Bid the Owner accepts, and to which the Owner makes an award of contract, subject to stated conditions.
42. *Supplementary Conditions*—The part of the Contract that amends or supplements these General Conditions.
43. *Supplier*—A manufacturer, fabricator, supplier, distributor, materialman, or vendor having a direct contract with Contractor or with any Subcontractor to furnish materials or equipment to be incorporated in the Work by Contractor or a Subcontractor.
44. *Technical Data*—Those items expressly identified as Technical Data in the Supplementary Conditions, with respect to either (a) subsurface conditions at the Site, or physical conditions relating to existing surface or subsurface structures at the Site (except Underground Facilities) or (b) Hazardous Environmental Conditions at the Site. If no such express identifications of Technical Data have been made with respect to conditions at the Site, then the data contained in boring logs, recorded measurements of subsurface water levels, laboratory test results, and other factual, objective information regarding conditions at the Site that are set forth in any geotechnical or environmental report prepared for the Project and made available to Contractor are hereby defined as Technical Data with respect to conditions at the Site under Paragraphs 5.03, 5.04, and 5.06.
45. *Underground Facilities*—All underground pipelines, conduits, ducts, cables, wires, manholes, vaults, tanks, tunnels, or other such facilities or attachments, and any encasements containing such facilities, including but not limited to those that convey electricity, gases, steam, liquid petroleum products, telephone or other communications, fiber optic transmissions, cable television, water, wastewater, storm water, other liquids or chemicals, or traffic or other control systems.
46. *Unit Price Work*—Work to be paid for on the basis of unit prices.
47. *Work*—The entire construction or the various separately identifiable parts thereof required to be provided under the Contract Documents. Work includes and is the result of performing or providing all labor, services, and documentation necessary to produce such construction; furnishing, installing, and incorporating all materials and equipment into such construction; and may include related services such as testing, start-up, and commissioning, all as required by the Contract Documents.

48. *Work Change Directive*—A written directive to Contractor issued on or after the Effective Date of the Contract, signed by Owner and recommended by Engineer, ordering an addition, deletion, or revision in the Work.

#### 1.02 Terminology

- A. The words and terms discussed in the following paragraphs are not defined but, when used in the Bidding Requirements or Contract Documents, have the indicated meaning.
- B. *Intent of Certain Terms or Adjectives:*
1. The Contract Documents include the terms “as allowed,” “as approved,” “as ordered,” “as directed” or terms of like effect or import to authorize an exercise of professional judgment by Engineer. In addition, the adjectives “reasonable,” “suitable,” “acceptable,” “proper,” “satisfactory,” or adjectives of like effect or import are used to describe an action or determination of Engineer as to the Work. It is intended that such exercise of professional judgment, action, or determination will be solely to evaluate, in general, the Work for compliance with the information in the Contract Documents and with the design concept of the Project as a functioning whole as shown or indicated in the Contract Documents (unless there is a specific statement indicating otherwise). The use of any such term or adjective is not intended to and shall not be effective to assign to Engineer any duty or authority to supervise or direct the performance of the Work, or any duty or authority to undertake responsibility contrary to the provisions of Article 10 or any other provision of the Contract Documents.
- C. *Day:*
1. The word “day” means a calendar day of 24 hours measured from midnight to the next midnight.
- D. *Defective:*
1. The word “defective,” when modifying the word “Work,” refers to Work that is unsatisfactory, faulty, or deficient in that it:
    - a. does not conform to the Contract Documents; or
    - b. does not meet the requirements of any applicable inspection, reference standard, test, or approval referred to in the Contract Documents; or
    - c. has been damaged prior to Engineer’s recommendation of final payment (unless responsibility for the protection thereof has been assumed by Owner at Substantial Completion in accordance with Paragraph 15.03 or 15.04).
- E. *Furnish, Install, Perform, Provide:*
1. The word “furnish,” when used in connection with services, materials, or equipment, shall mean to supply and deliver said services, materials, or equipment to the Site (or some other specified location) ready for use or installation and in usable or operable condition.
  2. The word “install,” when used in connection with services, materials, or equipment, shall mean to put into use or place in final position said services, materials, or equipment complete and ready for intended use.

3. The words "perform" or "provide," when used in connection with services, materials, or equipment, shall mean to furnish and install said services, materials, or equipment complete and ready for intended use.
4. If the Contract Documents establish an obligation of Contractor with respect to specific services, materials, or equipment, but do not expressly use any of the four words "furnish," "install," "perform," or "provide," then Contractor shall furnish and install said services, materials, or equipment complete and ready for intended use.
- F. Unless stated otherwise in the Contract Documents, words or phrases that have a well-known technical or construction industry or trade meaning are used in the Contract Documents in accordance with such recognized meaning.

## ARTICLE 2 – PRELIMINARY MATTERS

### 2.01 Delivery of Bonds and Evidence of Insurance

- A. **Bonds:** When Contractor delivers the executed counterparts of the Agreement to Owner, Contractor shall also deliver to Owner such bonds as Contractor may be required to furnish.
- B. **Evidence of Contractor's Insurance:** When Contractor delivers the executed counterparts of the Agreement to Owner, Contractor shall also deliver to Owner, with copies to each named insured and additional insured (as identified in the Supplementary Conditions or elsewhere in the Contract), the certificates and other evidence of insurance required to be provided by Contractor in accordance with Article 6.
- C. **Evidence of Owner's Insurance:** After receipt of the executed counterparts of the Agreement and all required bonds and insurance documentation, Owner shall promptly deliver to Contractor, with copies to each named insured and additional insured (as identified in the Supplementary Conditions or otherwise), the certificates and other evidence of insurance required to be provided by Owner under Article 6.

### 2.02 Copies of Documents

- A. Owner shall furnish to Contractor four printed copies of the Contract (including one fully executed counterpart of the Agreement), and one copy in electronic portable document format (PDF). Additional printed copies will be furnished upon request at the cost of reproduction.
- B. Owner shall maintain and safeguard at least one original printed record version of the Contract, including Drawings and Specifications signed and sealed by Engineer and other design professionals. Owner shall make such original printed record version of the Contract available to Contractor for review. Owner may delegate the responsibilities under this provision to Engineer.

### 2.03 Before Starting Construction

- A. **Preliminary Schedules:** Within 10 days after the Effective Date of the Contract (or as otherwise specifically required by the Contract Documents), Contractor shall submit to Engineer for timely review:
  1. a preliminary Progress Schedule indicating the times (numbers of days or dates) for starting and completing the various stages of the Work, including any Milestones specified in the Contract;
  2. a preliminary Schedule of Submittals; and

3. a preliminary Schedule of Values for all of the Work which includes quantities and prices of items which when added together equal the Contract Price and subdivides the Work into component parts in sufficient detail to serve as the basis for progress payments during performance of the Work. Such prices will include an appropriate amount of overhead and profit applicable to each item of Work.

### 2.04 Preconstruction Conference; Designation of Authorized Representatives

- A. Before any Work at the Site is started, a conference attended by Owner, Contractor, Engineer, and others as appropriate will be held to establish a working understanding among the parties as to the Work and to discuss the schedules referred to in Paragraph 2.03.A, procedures for handling Shop Drawings, Samples, and other submittals, processing Applications for Payment, electronic or digital transmittals, and maintaining required records.
- B. At this conference Owner and Contractor each shall designate, in writing, a specific individual to act as its authorized representative with respect to the services and responsibilities under the Contract. Such individuals shall have the authority to transmit and receive information, render decisions relative to the Contract, and otherwise act on behalf of each respective party.

### 2.05 Initial Acceptance of Schedules

- A. At least 10 days before submission of the first Application for Payment a conference, attended by Contractor, Engineer, and others as appropriate, will be held to review for acceptability to Engineer as provided below the schedules submitted in accordance with Paragraph 2.03.A. Contractor shall have an additional 10 days to make corrections and adjustments and to complete and resubmit the schedules. No progress payment shall be made to Contractor until acceptable schedules are submitted to Engineer.
  1. The Progress Schedule will be acceptable to Engineer if it provides an orderly progression of the Work to completion within the Contract Times. Such acceptance will not impose on Engineer responsibility for the Progress Schedule, for sequencing, scheduling, or progress of the Work, nor interfere with or relieve Contractor from Contractor's full responsibility therefor.
  2. Contractor's Schedule of Submittals will be acceptable to Engineer if it provides a workable arrangement for reviewing and processing the required submittals.
  3. Contractor's Schedule of Values will be acceptable to Engineer as to form and substance if it provides a reasonable allocation of the Contract Price to the component parts of the Work.

### 2.06 Electronic Transmittals

- A. Except as otherwise stated elsewhere in the Contract, the Owner, Engineer, and Contractor may transmit, and shall accept, Project-related correspondence, text, data, documents, drawings, information, and graphics, including but not limited to Shop Drawings and other submittals, in electronic media or digital format, either directly, or through access to a secure Project website.
- B. If the Contract does not establish protocols for electronic or digital transmittals, then Owner, Engineer, and Contractor shall jointly develop such protocols.
- C. When transmitting items in electronic media or digital format, the transmitting party makes no representations as to long term compatibility, usability, or readability of the items resulting from the recipient's use of software application packages, operating systems, or

computer hardware differing from those used in the drafting or transmittal of the items, or from those established in applicable transmittal protocols.

### ARTICLE 3 – DOCUMENTS: INTENT, REQUIREMENTS, REUSE

#### 3.01 Intent

- A. The Contract Documents are complementary; what is required by one is as binding as if required by all.
- B. It is the intent of the Contract Documents to describe a functionally complete project (or part thereof) to be constructed in accordance with the Contract Documents.
- C. Unless otherwise stated in the Contract Documents, if there is a discrepancy between the electronic or digital versions of the Contract Documents (including any printed copies derived from such electronic or digital versions) and the printed record version, the printed record version shall govern.
- D. The Contract supersedes prior negotiations, representations, and agreements, whether written or oral.
- E. Engineer will issue clarifications and interpretations of the Contract Documents as provided herein.

#### 3.02 Reference Standards

##### A. Standards Specifications, Codes, Laws and Regulations

1. Reference in the Contract Documents to standard specifications, manuals, reference standards, or codes of any technical society, organization, or association, or to Laws or Regulations, whether such reference be specific or by implication, shall mean the standard specification, manual, reference standard, code, or Laws or Regulations in effect at the time of opening of Bids (or on the Effective Date of the Contract if there were no Bids), except as may be otherwise specifically stated in the Contract Documents.
2. No provision of any such standard specification, manual, reference standard, or code, or any instruction of a Supplier, shall be effective to change the duties or responsibilities of Owner, Contractor, or Engineer, or any of their subcontractors, consultants, agents, or employees, from those set forth in the part of the Contract Documents prepared by or for Engineer. No such provision or instruction shall be effective to assign to Owner, Engineer, or any of their officers, directors, members, partners, employees, agents, consultants, or subcontractors, any duty or authority to supervise or direct the performance of the Work or any duty or authority to undertake responsibility inconsistent with the provisions of the part of the Contract Documents prepared by or for Engineer.

#### 3.03 Reporting and Resolving Discrepancies

##### A. Reporting Discrepancies:

1. *Contractor's Verification of Figures and Field Measurements:* Before undertaking each part of the Work, Contractor shall carefully study the Contract Documents, and check and verify pertinent figures and dimensions therein, particularly with respect to applicable field measurements. Contractor shall promptly report in writing to Engineer any conflict, error, ambiguity, or discrepancy that Contractor discovers, or has actual knowledge of, and shall not proceed with any Work affected thereby until the conflict,

error, ambiguity, or discrepancy is resolved, by a clarification or interpretation by Engineer, or by an amendment or supplement to the Contract Documents issued pursuant to Paragraph 11.01.

2. *Contractor's Review of Contract Documents:* If, before or during the performance of the Work, Contractor discovers any conflict, error, ambiguity, or discrepancy within the Contract Documents, or between the Contract Documents and (a) any applicable Law or Regulation, (b) actual field conditions, (c) any standard specification, manual, reference standard, or code, or (d) any instruction of any Supplier, then Contractor shall promptly report it to Engineer in writing. Contractor shall not proceed with the Work affected thereby (except in an emergency as required by Paragraph 7.15) until the conflict, error, ambiguity, or discrepancy is resolved, by a clarification or interpretation by Engineer, or by an amendment or supplement to the Contract Documents issued pursuant to Paragraph 11.01.
3. Contractor shall not be liable to Owner or Engineer for failure to report any conflict, error, ambiguity, or discrepancy in the Contract Documents unless Contractor had actual knowledge thereof.

##### B. Resolving Discrepancies:

1. Except as may be otherwise specifically stated in the Contract Documents, the provisions of the part of the Contract Documents prepared by or for Engineer shall take precedence in resolving any conflict, error, ambiguity, or discrepancy between such provisions of the Contract Documents and:
  - a. the provisions of any standard specification, manual, reference standard, or code, or the instruction of any Supplier (whether or not specifically incorporated by reference as a Contract Document); or
  - b. the provisions of any Laws or Regulations applicable to the performance of the Work (unless such an interpretation of the provisions of the Contract Documents would result in violation of such Law or Regulation).

#### 3.04 Requirements of the Contract Documents

- A. During the performance of the Work and until final payment, Contractor and Owner shall submit to the Engineer all matters in question concerning the requirements of the Contract Documents (sometimes referred to as requests for information or interpretation—RFIs), or relating to the acceptability of the Work under the Contract Documents, as soon as possible after such matters arise. Engineer will be the initial interpreter of the requirements of the Contract Documents, and judge of the acceptability of the Work thereunder.
- B. Engineer will, with reasonable promptness, render a written clarification, interpretation, or decision on the issue submitted, or initiate an amendment or supplement to the Contract Documents. Engineer's written clarification, interpretation, or decision will be final and binding on Contractor, unless it appeals by submitting a Change Proposal, and on Owner, unless it appeals by filing a Claim.
- C. If a submitted matter in question concerns terms and conditions of the Contract Documents that do not involve (1) the performance or acceptability of the Work under the Contract Documents, (2) the design (as set forth in the Drawings, Specifications, or otherwise), or (3) other engineering or technical matters, then Engineer will promptly give written notice to Owner and Contractor that Engineer is unable to provide a decision or interpretation. If Owner and Contractor are unable to agree on resolution of such a matter in question, either party may pursue resolution as provided in Article 12.

### 3.05 Reuse of Documents

- A. Contractor and its Subcontractors and Suppliers shall not:
1. have or acquire any title to or ownership rights in any of the Drawings, Specifications, or other documents (or copies of any thereof) prepared by or bearing the seal of Engineer or its consultants, including electronic media editions, or reuse any such Drawings, Specifications, other documents, or copies thereof on extensions of the Project or any other project without written consent of Owner and Engineer and specific written verification or adaptation by Engineer; or
  2. have or acquire any title or ownership rights in any other Contract Documents, reuse any such Contract Documents for any purpose without Owner's express written consent, or violate any copyrights pertaining to such Contract Documents.
- B. The prohibitions of this Paragraph 3.05 will survive final payment, or termination of the Contract. Nothing herein shall preclude Contractor from retaining copies of the Contract Documents for record purposes.

## ARTICLE 4 – COMMENCEMENT AND PROGRESS OF THE WORK

### 4.01 Commencement of Contract Times; Notice to Proceed

- A. The Contract Times will commence to run on the thirtieth day after the Effective Date of the Contract or, if a Notice to Proceed is given, on the day indicated in the Notice to Proceed. A Notice to Proceed may be given at any time within 30 days after the Effective Date of the Contract. In no event will the Contract Times commence to run later than the sixtieth day after the day of Bid opening or the thirtieth day after the Effective Date of the Contract, whichever date is earlier.

### 4.02 Starting the Work

- A. Contractor shall start to perform the Work on the date when the Contract Times commence to run. No Work shall be done at the Site prior to such date.

### 4.03 Reference Points

- A. Owner shall provide engineering surveys to establish reference points for construction which in Engineer's judgment are necessary to enable Contractor to proceed with the Work. Contractor shall be responsible for laying out the Work, shall protect and preserve the established reference points and property monuments, and shall make no changes or relocations without the prior written approval of Owner. Contractor shall report to Engineer whenever any reference point or property monument is lost or destroyed or requires relocation because of necessary changes in grades or locations, and shall be responsible for the accurate replacement or relocation of such reference points or property monuments by professionally qualified personnel.

### 4.04 Progress Schedule

- A. Contractor shall adhere to the Progress Schedule established in accordance with Paragraph 2.05 as it may be adjusted from time to time as provided below.
1. Contractor shall submit to Engineer for acceptance (to the extent indicated in Paragraph 2.05) proposed adjustments in the Progress Schedule that will not result in changing the Contract Times.

2. Proposed adjustments in the Progress Schedule that will change the Contract Times shall be submitted in accordance with the requirements of Article 11.

- B. Contractor shall carry on the Work and adhere to the Progress Schedule during all disputes or disagreements with Owner. No Work shall be delayed or postponed pending resolution of any disputes or disagreements, or during any appeal process, except as permitted by Paragraph 16.04, or as Owner and Contractor may otherwise agree in writing.

### 4.05 Delays in Contractor's Progress

- A. If Owner, Engineer, or anyone for whom Owner is responsible, delays, disrupts, or interferes with the performance or progress of the Work, then Contractor shall be entitled to an equitable adjustment in the Contract Times and Contract Price. Contractor's entitlement to an adjustment of the Contract Times is conditioned on such adjustment being essential to Contractor's ability to complete the Work within the Contract Times.
- B. Contractor shall not be entitled to an adjustment in Contract Price or Contract Times for delay, disruption, or interference caused by or within the control of Contractor. Delay, disruption, and interference attributable to and within the control of a Subcontractor or Supplier shall be deemed to be within the control of Contractor.
- C. If Contractor's performance or progress is delayed, disrupted, or interfered with by unanticipated causes not the fault of and beyond the control of Owner, Contractor, and those for which they are responsible, then Contractor shall be entitled to an equitable adjustment in Contract Times. Contractor's entitlement to an adjustment of the Contract Times is conditioned on such adjustment being essential to Contractor's ability to complete the Work within the Contract Times. Such an adjustment shall be Contractor's sole and exclusive remedy for the delays, disruption, and interference described in this paragraph. Causes of delay, disruption, or interference that may give rise to an adjustment in Contract Times under this paragraph include but are not limited to the following:
1. severe and unavoidable natural catastrophes such as fires, floods, epidemics, and earthquakes;
  2. abnormal weather conditions;
  3. acts or failures to act of utility owners (other than those performing other work at or adjacent to the Site by arrangement with the Owner, as contemplated in Article 8); and
  4. acts of war or terrorism.
- D. Delays, disruption, and interference to the performance or progress of the Work resulting from the existence of a differing subsurface or physical condition, an Underground Facility that was not shown or indicated by the Contract Documents, or not shown or indicated with reasonable accuracy, and those resulting from Hazardous Environmental Conditions, are governed by Article 5.
- E. Paragraph 8.03 governs delays, disruption, and interference to the performance or progress of the Work resulting from the performance of certain other work at or adjacent to the Site.
- F. Contractor shall not be entitled to an adjustment in Contract Price or Contract Times for any delay, disruption, or interference if such delay is concurrent with a delay, disruption, or interference caused by or within the control of Contractor.

- G. Contractor must submit any Change Proposal seeking an adjustment in Contract Price or Contract Times under this paragraph within 30 days of the commencement of the delaying, disrupting, or interfering event.

**ARTICLE 5 – AVAILABILITY OF LANDS; SUBSURFACE AND PHYSICAL CONDITIONS; HAZARDOUS ENVIRONMENTAL CONDITIONS**

**5.01 Availability of Lands**

- A. Owner shall furnish the Site. Owner shall notify Contractor of any encumbrances or restrictions not of general application but specifically related to use of the Site with which Contractor must comply in performing the Work.
- B. Upon reasonable written request, Owner shall furnish Contractor with a current statement of record legal title and legal description of the lands upon which permanent improvements are to be made and Owner's interest therein as necessary for giving notice of or filing a mechanic's or construction lien against such lands in accordance with applicable Laws and Regulations.
- C. Contractor shall provide for all additional lands and access thereto that may be required for temporary construction facilities or storage of materials and equipment.

**5.02 Use of Site and Other Areas**

**A. Limitation on Use of Site and Other Areas:**

1. Contractor shall confine construction equipment, temporary construction facilities, the storage of materials and equipment, and the operations of workers to the Site, adjacent areas that Contractor has arranged to use through construction easements or otherwise, and other adjacent areas permitted by Laws and Regulations, and shall not unreasonably encumber the Site and such other adjacent areas with construction equipment or other materials or equipment. Contractor shall assume full responsibility for (a) damage to the Site; (b) damage to any such other adjacent areas used for Contractor's operations; (c) damage to any other adjacent land or areas; and (d) for injuries and losses sustained by the owners or occupants of any such land or areas; provided that such damage or injuries result from the performance of the Work or from other actions or conduct of the Contractor or those for which Contractor is responsible.
2. If a damage or injury claim is made by the owner or occupant of any such land or area because of the performance of the Work, or because of other actions or conduct of the Contractor or those for which Contractor is responsible, Contractor shall (a) take immediate corrective or remedial action as required by Paragraph 7.12, or otherwise; (b) promptly attempt to settle the claim as to all parties through negotiations with such owner or occupant, or otherwise resolve the claim by arbitration or other dispute resolution proceeding, or at law; and (c) to the fullest extent permitted by Laws and Regulations, indemnify and hold harmless Owner and Engineer, and the officers, directors, members, partners, employees, agents, consultants and subcontractors of each and any of them from and against any such claim, and against all costs, losses, and damages (including but not limited to all fees and charges of engineers, architects, attorneys, and other professionals and all court or arbitration or other dispute resolution costs) arising out of or relating to any claim or action, legal or equitable, brought by any such owner or occupant against Owner, Engineer, or any other party indemnified hereunder to the extent caused directly or indirectly, in whole or in part

by, or based upon, Contractor's performance of the Work, or because of other actions or conduct of the Contractor or those for which Contractor is responsible.

- B. **Removal of Debris During Performance of the Work:** During the progress of the Work the Contractor shall keep the Site and other adjacent areas free from accumulations of waste materials, rubbish, and other debris. Removal and disposal of such waste materials, rubbish, and other debris shall conform to applicable Laws and Regulations.
- C. **Cleaning:** Prior to Substantial Completion of the Work Contractor shall clean the Site and the Work and make it ready for utilization by Owner. At the completion of the Work Contractor shall remove from the Site and adjacent areas all tools, appliances, construction equipment and machinery, and surplus materials and shall restore to original condition all property not designated for alteration by the Contract Documents.
- D. **Loading of Structures:** Contractor shall not load nor permit any part of any structure to be loaded in any manner that will endanger the structure, nor shall Contractor subject any part of the Work or adjacent structures or land to stresses or pressures that will endanger them.

**5.03 Subsurface and Physical Conditions**

**A. Reports and Drawings:** The Supplementary Conditions identify:

1. those reports known to Owner of explorations and tests of subsurface conditions at or adjacent to the Site;
2. those drawings known to Owner of physical conditions relating to existing surface or subsurface structures at the Site (except Underground Facilities); and
3. Technical Data contained in such reports and drawings.

**B. Reliance by Contractor on Technical Data Authorized:** Contractor may rely upon the accuracy of the Technical Data expressly identified in the Supplementary Conditions with respect to such reports and drawings, but such reports and drawings are not Contract Documents. If no such express identification has been made, then Contractor may rely upon the accuracy of the Technical Data (as defined in Article 1) contained in any geotechnical or environmental report prepared for the Project and made available to Contractor. Except for such reliance on Technical Data, Contractor may not rely upon or make any claim against Owner or Engineer, or any of their officers, directors, members, partners, employees, agents, consultants, or subcontractors, with respect to:

1. the completeness of such reports and drawings for Contractor's purposes, including, but not limited to, any aspects of the means, methods, techniques, sequences, and procedures of construction to be employed by Contractor, and safety precautions and programs incident thereto; or
2. other data, interpretations, opinions, and information contained in such reports or shown or indicated in such drawings; or
3. any Contractor interpretation of or conclusion drawn from any Technical Data or any such other data, interpretations, opinions, or information.

5.04 *Differing Subsurface or Physical Conditions*

- A. *Notice by Contractor:* If Contractor believes that any subsurface or physical condition that is uncovered or revealed at the Site either:
1. is of such a nature as to establish that any Technical Data on which Contractor is entitled to rely as provided in Paragraph 5.03 is materially inaccurate; or
  2. is of such a nature as to require a change in the Drawings or Specifications; or
  3. differs materially from that shown or indicated in the Contract Documents; or
  4. is of an unusual nature, and differs materially from conditions ordinarily encountered and generally recognized as inherent in work of the character provided for in the Contract Documents;

then Contractor shall, promptly after becoming aware thereof and before further disturbing the subsurface or physical conditions or performing any Work in connection therewith (except in an emergency as required by Paragraph 7.15), notify Owner and Engineer in writing about such condition. Contractor shall not further disturb such condition or perform any Work in connection therewith (except with respect to an emergency) until receipt of a written statement permitting Contractor to do so.

- B. *Engineer's Review:* After receipt of written notice as required by the preceding paragraph, Engineer will promptly review the subsurface or physical condition in question; determine the necessity of Owner's obtaining additional exploration or tests with respect to the condition; conclude whether the condition falls within any one or more of the differing site condition categories in Paragraph 5.04.A above; obtain any pertinent cost or schedule information from Contractor; prepare recommendations to Owner regarding the Contractor's resumption of Work in connection with the subsurface or physical condition in question and the need for any change in the Drawings or Specifications; and advise Owner in writing of Engineer's findings, conclusions, and recommendations.

- C. *Owner's Statement to Contractor Regarding Site Condition:* After receipt of Engineer's written findings, conclusions, and recommendations, Owner shall issue a written statement to Contractor (with a copy to Engineer) regarding the subsurface or physical condition in question, addressing the resumption of Work in connection with such condition, indicating whether any change in the Drawings or Specifications will be made, and adopting or rejecting Engineer's written findings, conclusions, and recommendations, in whole or in part.

D. *Possible Price and Times Adjustments:*

1. Contractor shall be entitled to an equitable adjustment in Contract Price or Contract Times, or both, to the extent that the existence of a differing subsurface or physical condition, or any related delay, disruption, or interference, causes an increase or decrease in Contractor's cost of, or time required for, performance of the Work; subject, however, to the following:
  - a. such condition must fall within any one or more of the categories described in Paragraph 5.04.A;
  - b. with respect to Work that is paid for on a unit price basis, any adjustment in Contract Price will be subject to the provisions of Paragraph 13.03; and,

- c. Contractor's entitlement to an adjustment of the Contract Times is conditioned on such adjustment being essential to Contractor's ability to complete the Work within the Contract Times.
2. Contractor shall not be entitled to any adjustment in the Contract Price or Contract Times with respect to a subsurface or physical condition if:
  - a. Contractor knew of the existence of such condition at the time Contractor made a commitment to Owner with respect to Contract Price and Contract Times by the submission of a Bid or becoming bound under a negotiated contract, or otherwise; or
  - b. the existence of such condition reasonably could have been discovered or revealed as a result of any examination, investigation, exploration, test, or study of the Site and contiguous areas expressly required by the Bidding Requirements or Contract Documents to be conducted by or for Contractor prior to Contractor's making such commitment; or
  - c. Contractor failed to give the written notice as required by Paragraph 5.04.A.
3. If Owner and Contractor agree regarding Contractor's entitlement to and the amount or extent of any adjustment in the Contract Price or Contract Times, or both, then any such adjustment shall be set forth in a Change Order.
4. Contractor may submit a Change Proposal regarding its entitlement to or the amount or extent of any adjustment in the Contract Price or Contract Times, or both, no later than 30 days after Owner's issuance of the Owner's written statement to Contractor regarding the subsurface or physical condition in question.

5.05 *Underground Facilities*

- A. *Contractor's Responsibilities:* The information and data shown or indicated in the Contract Documents with respect to existing Underground Facilities at or adjacent to the Site is based on information and data furnished to Owner or Engineer by the owners of such Underground Facilities, including Owner, or by others. Unless it is otherwise expressly provided in the Supplementary Conditions:

1. Owner and Engineer do not warrant or guarantee the accuracy or completeness of any such information or data provided by others; and
2. the cost of all of the following will be included in the Contract Price, and Contractor shall have full responsibility for:
  - a. reviewing and checking all information and data regarding existing Underground Facilities at the Site;
  - b. locating all Underground Facilities shown or indicated in the Contract Documents as being at the Site;
  - c. coordination of the Work with the owners (including Owner) of such Underground Facilities, during construction; and
  - d. the safety and protection of all existing Underground Facilities at the Site, and repairing any damage thereto resulting from the Work.

- B. *Notice by Contractor:* If Contractor believes that an Underground Facility that is uncovered or revealed at the Site was not shown or indicated in the Contract Documents, or was not shown or indicated with reasonable accuracy, then Contractor shall, promptly after

becoming aware thereof and before further disturbing conditions affected thereby or performing any Work in connection therewith (except in an emergency as required by Paragraph 7.15), identify the owner of such Underground Facility and give written notice to that owner and to Owner and Engineer.

- C. *Engineer's Review:* Engineer will promptly review the Underground Facility and conclude whether such Underground Facility was not shown or indicated in the Contract Documents, or was not shown or indicated with reasonable accuracy; obtain any pertinent cost or schedule information from Contractor; prepare recommendations to Owner regarding the Contractor's resumption of Work in connection with the Underground Facility in question; determine the extent, if any, to which a change is required in the Drawings or Specifications to reflect and document the consequences of the existence or location of the Underground Facility; and advise Owner in writing of Engineer's findings, conclusions, and recommendations. During such time, Contractor shall be responsible for the safety and protection of such Underground Facility.
- D. *Owner's Statement to Contractor Regarding Underground Facility:* After receipt of Engineer's written findings, conclusions, and recommendations, Owner shall issue a written statement to Contractor (with a copy to Engineer) regarding the Underground Facility in question, addressing the resumption of Work in connection with such Underground Facility, indicating whether any change in the Drawings or Specifications will be made, and adopting or rejecting Engineer's written findings, conclusions, and recommendations in whole or in part.
- E. *Possible Price and Times Adjustments:*
1. Contractor shall be entitled to an equitable adjustment in the Contract Price or Contract Times, or both, to the extent that any existing Underground Facility at the Site that was not shown or indicated in the Contract Documents, or was not shown or indicated with reasonable accuracy, or any related delay, disruption, or interference, causes an increase or decrease in Contractor's cost of, or time required for, performance of the Work; subject, however, to the following:
    - a. Contractor did not know of and could not reasonably have been expected to be aware of or to have anticipated the existence or actual location of the Underground Facility in question;
    - b. With respect to Work that is paid for on a unit price basis, any adjustment in Contract Price will be subject to the provisions of Paragraph 13.03;
    - c. Contractor's entitlement to an adjustment of the Contract Times is conditioned on such adjustment being essential to Contractor's ability to complete the Work within the Contract Times; and
    - d. Contractor gave the notice required in Paragraph 5.05.B.
  2. If Owner and Contractor agree regarding Contractor's entitlement to and the amount or extent of any adjustment in the Contract Price or Contract Times, or both, then any such adjustment shall be set forth in a Change Order.
  3. Contractor may submit a Change Proposal regarding its entitlement to or the amount or extent of any adjustment in the Contract Price or Contract Times, or both, no later than 30 days after Owner's issuance of the Owner's written statement to Contractor regarding the Underground Facility in question.

#### 5.06 Hazardous Environmental Conditions at Site

- A. *Reports and Drawings:* The Supplementary Conditions identify:
1. those reports and drawings known to Owner relating to Hazardous Environmental Conditions that have been identified at or adjacent to the Site; and
  2. Technical Data contained in such reports and drawings.
- B. *Reliance by Contractor on Technical Data Authorized:* Contractor may rely upon the accuracy of the Technical Data expressly identified in the Supplementary Conditions with respect to such reports and drawings, but such reports and drawings are not Contract Documents. If no such express identification has been made, then Contractor may rely on the accuracy of the Technical Data (as defined in Article 1) contained in any geotechnical or environmental report prepared for the Project and made available to Contractor. Except for such reliance on Technical Data, Contractor may not rely upon or make any claim against Owner or Engineer, or any of their officers, directors, members, partners, employees, agents, consultants, or subcontractors with respect to:
1. the completeness of such reports and drawings for Contractor's purposes, including, but not limited to, any aspects of the means, methods, techniques, sequences and procedures of construction to be employed by Contractor and safety precautions and programs incident thereto; or
  2. other data, interpretations, opinions and information contained in such reports or shown or indicated in such drawings; or
  3. any Contractor interpretation of or conclusion drawn from any Technical Data or any such other data, interpretations, opinions or information.
- C. Contractor shall not be responsible for removing or remediating any Hazardous Environmental Condition encountered, uncovered, or revealed at the Site unless such removal or remediation is expressly identified in the Contract Documents to be within the scope of the Work.
- D. Contractor shall be responsible for controlling, containing, and duly removing all Constituents of Concern brought to the Site by Contractor, Subcontractors, Suppliers, or anyone else for whom Contractor is responsible, and for any associated costs; and for the costs of removing and remediating any Hazardous Environmental Condition created by the presence of any such Constituents of Concern.
- E. If Contractor encounters, uncovers, or reveals a Hazardous Environmental Condition whose removal or remediation is not expressly identified in the Contract Documents as being within the scope of the Work, or if Contractor or anyone for whom Contractor is responsible creates a Hazardous Environmental Condition, then Contractor shall immediately: (1) secure or otherwise isolate such condition; (2) stop all Work in connection with such condition and in any area affected thereby (except in an emergency as required by Paragraph 7.15); and (3) notify Owner and Engineer (and promptly thereafter confirm such notice in writing). Owner shall promptly consult with Engineer concerning the necessity for Owner to retain a qualified expert to evaluate such condition or take corrective action, if any. Promptly after consulting with Engineer, Owner shall take such actions as are necessary to permit Owner to timely obtain required permits and provide Contractor the written notice required by Paragraph 5.06.F. If Contractor or anyone for whom Contractor is responsible created the Hazardous Environmental Condition in question, then Owner may remove and remediate the Hazardous Environmental Condition, and impose a set-off against payments to account for the associated costs.

- F. Contractor shall not resume Work in connection with such Hazardous Environmental Condition or in any affected area until after Owner has obtained any required permits related thereto, and delivered written notice to Contractor either (1) specifying that such condition and any affected area is or has been rendered safe for the resumption of Work, or (2) specifying any special conditions under which such Work may be resumed safely.
- G. If Owner and Contractor cannot agree as to entitlement to or on the amount or extent, if any, of any adjustment in Contract Price or Contract Times, or both, as a result of such Work stoppage or such special conditions under which Work is agreed to be resumed by Contractor, then within 30 days of Owner's written notice regarding the resumption of Work, Contractor may submit a Change Proposal, or Owner may impose a set-off.
- H. If after receipt of such written notice Contractor does not agree to resume such Work based on a reasonable belief it is unsafe, or does not agree to resume such Work under such special conditions, then Owner may order the portion of the Work that is in the area affected by such condition to be deleted from the Work, following the contractual change procedures in Article 11. Owner may have such deleted portion of the Work performed by Owner's own forces or others in accordance with Article 8.
- I. To the fullest extent permitted by Laws and Regulations, Owner shall indemnify and hold harmless Contractor, Subcontractors, and Engineer, and the officers, directors, members, partners, employees, agents, consultants, and subcontractors of each and any of them from and against all claims, costs, losses, and damages (including but not limited to all fees and charges of engineers, architects, attorneys, and other professionals and all court or arbitration or other dispute resolution costs) arising out of or relating to a Hazardous Environmental Condition, provided that such Hazardous Environmental Condition (1) was not shown or indicated in the Drawings, Specifications, or other Contract Documents, identified as Technical Data entitled to limited reliance pursuant to Paragraph 5.06.B, or identified in the Contract Documents to be included within the scope of the Work, and (2) was not created by Contractor or by anyone for whom Contractor is responsible. Nothing in this Paragraph 5.06.I shall obligate Owner to indemnify any individual or entity from and against the consequences of that individual's or entity's own negligence.
- J. To the fullest extent permitted by Laws and Regulations, Contractor shall indemnify and hold harmless Owner and Engineer, and the officers, directors, members, partners, employees, agents, consultants, and subcontractors of each and any of them from and against all claims, costs, losses, and damages (including but not limited to all fees and charges of engineers, architects, attorneys, and other professionals and all court or arbitration or other dispute resolution costs) arising out of or relating to the failure to control, contain, or remove a Constituent of Concern brought to the Site by Contractor or by anyone for whom Contractor is responsible, or to a Hazardous Environmental Condition created by Contractor or by anyone for whom Contractor is responsible. Nothing in this Paragraph 5.06.J shall obligate Contractor to indemnify any individual or entity from and against the consequences of that individual's or entity's own negligence.
- K. The provisions of Paragraphs 5.03, 5.04, and 5.05 do not apply to the presence of Constituents of Concern or to a Hazardous Environmental Condition uncovered or revealed at the Site.

## ARTICLE 6 – BONDS AND INSURANCE

### 6.01 Performance, Payment, and Other Bonds

- A. Contractor shall furnish a performance bond and a payment bond, each in an amount at least equal to the Contract Price, as security for the faithful performance and payment of all of Contractor's obligations under the Contract. These bonds shall remain in effect until one year after the date when final payment becomes due or until completion of the correction period specified in Paragraph 15.08, whichever is later, except as provided otherwise by Laws or Regulations, the Supplementary Conditions, or other specific provisions of the Contract. Contractor shall also furnish such other bonds as are required by the Supplementary Conditions or other specific provisions of the Contract.
- B. All bonds shall be in the form prescribed by the Contract except as provided otherwise by Laws or Regulations, and shall be executed by such sureties as are named in "Companies Holding Certificates of Authority as Acceptable Sureties on Federal Bonds and as Acceptable Reinsuring Companies" as published in Circular 570 (as amended and supplemented) by the Financial Management Service, Surety Bond Branch, U.S. Department of the Treasury. A bond signed by an agent or attorney-in-fact must be accompanied by a certified copy of that individual's authority to bind the surety. The evidence of authority shall show that it is effective on the date the agent or attorney-in-fact signed the accompanying bond.
- C. Contractor shall obtain the required bonds from surety companies that are duly licensed or authorized in the jurisdiction in which the Project is located to issue bonds in the required amounts.
- D. If the surety on a bond furnished by Contractor is declared bankrupt or becomes insolvent, or its right to do business is terminated in any state or jurisdiction where any part of the Project is located, or the surety ceases to meet the requirements above, then Contractor shall promptly notify Owner and Engineer and shall, within 20 days after the event giving rise to such notification, provide another bond and surety, both of which shall comply with the bond and surety requirements above.
- E. If Contractor has failed to obtain a required bond, Owner may exclude the Contractor from the Site and exercise Owner's termination rights under Article 16.
- F. Upon request, Owner shall provide a copy of the payment bond to any Subcontractor, Supplier, or other person or entity claiming to have furnished labor or materials used in the performance of the Work.

### 6.02 Insurance—General Provisions

- A. Owner and Contractor shall obtain and maintain insurance as required in this Article and in the Supplementary Conditions.
- B. All insurance required by the Contract to be purchased and maintained by Owner or Contractor shall be obtained from insurance companies that are duly licensed or authorized, in the state or jurisdiction in which the Project is located, to issue insurance policies for the required limits and coverages. Unless a different standard is indicated in the Supplementary Conditions, all companies that provide insurance policies required under this Contract shall have an A.M. Best rating of A-VII or better.
- C. Contractor shall deliver to Owner, with copies to each named insured and additional insured (as identified in this Article, in the Supplementary Conditions, or elsewhere in the Contract), certificates of insurance establishing that Contractor has obtained and is



maintaining the policies, coverages, and endorsements required by the Contract. Upon request by Owner or any other insured, Contractor shall also furnish other evidence of such required insurance, including but not limited to copies of policies and endorsements, and documentation of applicable self-insured retentions and deductibles. Contractor may block out (redact) any confidential premium or pricing information contained in any policy or endorsement furnished under this provision.

- D. Owner shall deliver to Contractor, with copies to each named insured and additional insured (as identified in this Article, the Supplementary Conditions, or elsewhere in the Contract), certificates of insurance establishing that Owner has obtained and is maintaining the policies, coverages, and endorsements required of Owner by the Contract (if any). Upon request by Contractor or any other insured, Owner shall also provide other evidence of such required insurance (if any), including but not limited to copies of policies and endorsements, and documentation of applicable self-insured retentions and deductibles. Owner may block out (redact) any confidential premium or pricing information contained in any policy or endorsement furnished under this provision.
- E. Failure of Owner or Contractor to demand such certificates or other evidence of the other party's full compliance with these insurance requirements, or failure of Owner or Contractor to identify a deficiency in compliance from the evidence provided, shall not be construed as a waiver of the other party's obligation to obtain and maintain such insurance.
- F. If either party does not purchase or maintain all of the insurance required of such party by the Contract, such party shall notify the other party in writing of such failure to purchase prior to the start of the Work, or of such failure to maintain prior to any change in the required coverage.
- G. If Contractor has failed to obtain and maintain required insurance, Owner may exclude the Contractor from the Site, impose an appropriate set-off against payment, and exercise Owner's termination rights under Article 16.
- H. Without prejudice to any other right or remedy, if a party has failed to obtain required insurance, the other party may elect to obtain equivalent insurance to protect such other party's interests at the expense of the party who was required to provide such coverage, and the Contract Price shall be adjusted accordingly.
- I. Owner does not represent that insurance coverage and limits established in this Contract necessarily will be adequate to protect Contractor or Contractor's interests.
- J. The insurance and insurance limits required herein shall not be deemed as a limitation on Contractor's liability under the indemnities granted to Owner and other individuals and entities in the Contract.

#### 6.03 Contractor's Insurance

- A. **Workers' Compensation:** Contractor shall purchase and maintain workers' compensation and employer's liability insurance for:
  - 1. claims under workers' compensation, disability benefits, and other similar employee benefit acts.
  - 2. United States Longshoreman and Harbor Workers' Compensation Act and Jones Act coverage (if applicable).
  - 3. claims for damages because of bodily injury, occupational sickness or disease, or death of Contractor's employees (by stop-gap endorsement in monopolist worker's compensation states).

- 4. Foreign voluntary worker compensation (if applicable).

- B. **Commercial General Liability—Claims Covered:** Contractor shall purchase and maintain commercial general liability insurance, covering all operations by or on behalf of Contractor, on an occurrence basis, against:
  - 1. claims for damages because of bodily injury, sickness or disease, or death of any person other than Contractor's employees.
  - 2. claims for damages insured by reasonably available personal injury liability coverage.
  - 3. claims for damages, other than to the Work itself, because of injury to or destruction of tangible property wherever located, including loss of use resulting therefrom.
- C. **Commercial General Liability—Form and Content:** Contractor's commercial liability policy shall be written on a 1996 (or later) ISO commercial general liability form (occurrence form) and include the following coverages and endorsements:
  - 1. Products and completed operations coverage:
    - a. Such insurance shall be maintained for three years after final payment.
    - b. Contractor shall furnish Owner and each other additional insured (as identified in the Supplementary Conditions or elsewhere in the Contract) evidence of continuation of such insurance at final payment and three years thereafter.
  - 2. Blanket contractual liability coverage, to the extent permitted by law, including but not limited to coverage of Contractor's contractual indemnity obligations in Paragraph 7.18.
  - 3. Broad form property damage coverage.
  - 4. Severability of interest.
  - 5. Underground, explosion, and collapse coverage.
  - 6. Personal injury coverage.
  - 7. Additional insured endorsements that include both ongoing operations and products and completed operations coverage through ISO Endorsements CG 20 10 10 01 and CG 20 37 10 01 (together); or CG 20 10 07 04 and CG 20 37 07 04 (together); or their equivalent.
  - 8. For design professional additional insureds, ISO Endorsement CG 20 32 07 04, "Additional Insured—Engineers, Architects or Surveyors Not Engaged by the Named Insured" or its equivalent.
- D. **Automobile liability:** Contractor shall purchase and maintain automobile liability insurance against claims for damages because of bodily injury or death of any person or property damage arising out of the ownership, maintenance, or use of any motor vehicle. The automobile liability policy shall be written on an occurrence basis.
- E. **Umbrella or excess liability:** Contractor shall purchase and maintain umbrella or excess liability insurance written over the underlying employer's liability, commercial general liability, and automobile liability insurance described in the paragraphs above. Subject to industry-standard exclusions, the coverage afforded shall follow form as to each and every one of the underlying policies.
- F. **Contractor's pollution liability insurance:** Contractor shall purchase and maintain a policy covering third-party injury and property damage claims, including clean-up costs, as a result

of pollution conditions arising from Contractor's operations and completed operations. This insurance shall be maintained for no less than three years after final completion.

- G. *Additional insureds:* The Contractor's commercial general liability, automobile liability, umbrella or excess, and pollution liability policies shall include and list as additional insureds Owner and Engineer, and any individuals or entities identified in the Supplementary Conditions; include coverage for the respective officers, directors, members, partners, employees, agents, consultants, and subcontractors of each and any of all such additional insureds; and the insurance afforded to these additional insureds shall provide primary coverage for all claims covered thereby (including as applicable those arising from both ongoing and completed operations) on a non-contributory basis. Contractor shall obtain all necessary endorsements to support these requirements.
- H. *Contractor's professional liability insurance:* If Contractor will provide or furnish professional services under this Contract, through a delegation of professional design services or otherwise, then Contractor shall be responsible for purchasing and maintaining applicable professional liability insurance. This insurance shall provide protection against claims arising out of performance of professional design or related services, and caused by a negligent error, omission, or act for which the insured party is legally liable. It shall be maintained throughout the duration of the Contract and for a minimum of two years after Substantial Completion. If such professional design services are performed by a Subcontractor, and not by Contractor itself, then the requirements of this paragraph may be satisfied through the purchasing and maintenance of such insurance by such Subcontractor.
- I. *General provisions:* The policies of insurance required by this Paragraph 6.03 shall:
  - 1. include at least the specific coverages provided in this Article.
  - 2. be written for not less than the limits of liability provided in this Article and in the Supplementary Conditions, or required by Laws or Regulations, whichever is greater.
  - 3. contain a provision or endorsement that the coverage afforded will not be canceled, materially changed, or renewal refused until at least 10 days prior written notice has been given to Contractor. Within three days of receipt of any such written notice, Contractor shall provide a copy of the notice to Owner, Engineer, and each other insured under the policy.
  - 4. remain in effect at least until final payment (and longer if expressly required in this Article) and at all times thereafter when Contractor may be correcting, removing, or replacing defective Work as a warranty or correction obligation, or otherwise, or returning to the Site to conduct other tasks arising from the Contract Documents.
  - 5. be appropriate for the Work being performed and provide protection from claims that may arise out of or result from Contractor's performance of the Work and Contractor's other obligations under the Contract Documents, whether it is to be performed by Contractor, any Subcontractor or Supplier, or by anyone directly or indirectly employed by any of them to perform any of the Work, or by anyone for whose acts any of them may be liable.
- J. The coverage requirements for specific policies of insurance must be met by such policies, and not by reference to excess or umbrella insurance provided in other policies.

#### 6.04 *Owner's Liability Insurance*

- A. In addition to the insurance required to be provided by Contractor under Paragraph 6.03, Owner, at Owner's option, may purchase and maintain at Owner's expense Owner's own liability insurance as will protect Owner against claims which may arise from operations under the Contract Documents.
- B. Owner's liability policies, if any, operate separately and independently from policies required to be provided by Contractor, and Contractor cannot rely upon Owner's liability policies for any of Contractor's obligations to the Owner, Engineer, or third parties.

#### 6.05 *Property Insurance*

- A. *Builder's Risk:* Unless otherwise provided in the Supplementary Conditions, Contractor shall purchase and maintain builder's risk insurance upon the Work on a completed value basis, in the amount of the full insurable replacement cost thereof (subject to such deductible amounts as may be provided in the Supplementary Conditions or required by Laws and Regulations). This insurance shall:
  - 1. include the Owner and Contractor as named insureds, and all Subcontractors, and any individuals or entities required by the Supplementary Conditions to be insured under such builder's risk policy, as insureds or named insureds. For purposes of the remainder of this Paragraph 6.05, Paragraphs 6.06 and 6.07, and any corresponding Supplementary Conditions, the parties required to be insured shall collectively be referred to as "insureds."
  - 2. be written on a builder's risk "all risk" policy form that shall at least include insurance for physical loss or damage to the Work, temporary buildings, falsework, and materials and equipment in transit, and shall insure against at least the following perils or causes of loss: fire; lightning; windstorm; riot; civil commotion; terrorism; vehicle impact; aircraft; smoke; theft; vandalism and malicious mischief; mechanical breakdown, boiler explosion, and artificially generated electric current; earthquake; volcanic activity, and other earth movement; flood; collapse; explosion; debris removal; demolition occasioned by enforcement of Laws and Regulations; water damage (other than that caused by flood); and such other perils or causes of loss as may be specifically required by the Supplementary Conditions. If insurance against mechanical breakdown, boiler explosion, and artificially generated electric current; earthquake; volcanic activity, and other earth movement; or flood, are not commercially available under builder's risk policies, by endorsement or otherwise, such insurance may be provided through other insurance policies acceptable to Owner and Contractor.
  - 3. cover, as insured property, at least the following: (a) the Work and all materials, supplies, machinery, apparatus, equipment, fixtures, and other property of a similar nature that are to be incorporated into or used in the preparation, fabrication, construction, erection, or completion of the Work, including Owner-furnished or assigned property; (b) spare parts inventory required within the scope of the Contract; and (c) temporary works which are not intended to form part of the permanent constructed Work but which are intended to provide working access to the Site, or to the Work under construction, or which are intended to provide temporary support for the Work under construction, including scaffolding, form work, fences, shoring, falsework, and temporary structures.
  - 4. cover expenses incurred in the repair or replacement of any insured property (including but not limited to fees and charges of engineers and architects).

5. extend to cover damage or loss to insured property while in temporary storage at the Site or in a storage location outside the Site (but not including property stored at the premises of a manufacturer or Supplier).
  6. extend to cover damage or loss to insured property while in transit.
  7. allow for partial occupation or use of the Work by Owner, such that those portions of the Work that are not yet occupied or used by Owner shall remain covered by the builder's risk insurance.
  8. allow for the waiver of the insurer's subrogation rights, as set forth below.
  9. provide primary coverage for all losses and damages caused by the perils or causes of loss covered.
  10. not include a co-insurance clause.
  11. include an exception for ensuing losses from physical damage or loss with respect to any defective workmanship, design, or materials exclusions.
  12. include performance/hot testing and start-up.
  13. be maintained in effect, subject to the provisions herein regarding Substantial Completion and partial occupancy or use of the Work by Owner, until the Work is complete.
- B. *Notice of Cancellation or Change:* All the policies of insurance (and the certificates or other evidence thereof) required to be purchased and maintained in accordance with this Paragraph 6.05 will contain a provision or endorsement that the coverage afforded will not be canceled or materially changed or renewal refused until at least 10 days prior written notice has been given to the purchasing policyholder. Within three days of receipt of any such written notice, the purchasing policyholder shall provide a copy of the notice to each other insured.
- C. *Deductibles:* The purchaser of any required builder's risk or property insurance shall pay for costs not covered because of the application of a policy deductible.
- D. *Partial Occupancy or Use by Owner:* If Owner will occupy or use a portion or portions of the Work prior to Substantial Completion of all the Work as provided in Paragraph 15.04, then Owner (directly, if it is the purchaser of the builder's risk policy, or through Contractor) will provide notice of such occupancy or use to the builder's risk insurer. The builder's risk insurance shall not be canceled or permitted to lapse on account of any such partial use or occupancy; rather, those portions of the Work that are occupied or used by Owner may come off the builder's risk policy, while those portions of the Work not yet occupied or used by Owner shall remain covered by the builder's risk insurance.
- E. *Additional Insurance:* If Contractor elects to obtain other special insurance to be included in or supplement the builder's risk or property insurance policies provided under this Paragraph 6.05, it may do so at Contractor's expense.
- F. *Insurance of Other Property:* If the express insurance provisions of the Contract do not require or address the insurance of a property item or interest, such as tools, construction equipment, or other personal property owned by Contractor, a Subcontractor, or an employee of Contractor or a Subcontractor, then the entity or individual owning such property item will be responsible for deciding whether to insure it, and if so in what amount.

#### 6.06 Waiver of Rights

- A. All policies purchased in accordance with Paragraph 6.05, expressly including the builder's risk policy, shall contain provisions to the effect that in the event of payment of any loss or damage the insurers will have no rights of recovery against any insureds thereunder, or against Engineer or its consultants, or their officers, directors, members, partners, employees, agents, consultants, or subcontractors. Owner and Contractor waive all rights against each other and the respective officers, directors, members, partners, employees, agents, consultants, and subcontractors of each and any of them, for all losses and damages caused by, arising out of, or resulting from any of the perils or causes of loss covered by such policies and any other property insurance applicable to the Work; and, in addition, waive all such rights against Engineer, its consultants, all Subcontractors, all individuals or entities identified in the Supplementary Conditions as insureds, and the officers, directors, members, partners, employees, agents, consultants, and subcontractors of each and any of them, under such policies for losses and damages so caused. None of the above waivers shall extend to the rights that any party making such waiver may have to the proceeds of insurance held by Owner or Contractor as trustee or fiduciary, or otherwise payable under any policy so issued.
- B. Owner waives all rights against Contractor, Subcontractors, and Engineer, and the officers, directors, members, partners, employees, agents, consultants and subcontractors of each and any of them, for:
1. loss due to business interruption, loss of use, or other consequential loss extending beyond direct physical loss or damage to Owner's property or the Work caused by, arising out of, or resulting from fire or other perils whether or not insured by Owner; and
  2. loss or damage to the completed Project or part thereof caused by, arising out of, or resulting from fire or other insured peril or cause of loss covered by any property insurance maintained on the completed Project or part thereof by Owner during partial occupancy or use pursuant to Paragraph 15.04, after Substantial Completion pursuant to Paragraph 15.03, or after final payment pursuant to Paragraph 15.06.
- C. Any insurance policy maintained by Owner covering any loss, damage or consequential loss referred to in Paragraph 6.06.B shall contain provisions to the effect that in the event of payment of any such loss, damage, or consequential loss, the insurers will have no rights of recovery against Contractor, Subcontractors, or Engineer, or the officers, directors, members, partners, employees, agents, consultants, or subcontractors of each and any of them.
- D. Contractor shall be responsible for assuring that the agreement under which a Subcontractor performs a portion of the Work contains provisions whereby the Subcontractor waives all rights against Owner, Contractor, all individuals or entities identified in the Supplementary Conditions as insureds, the Engineer and its consultants, and the officers, directors, members, partners, employees, agents, consultants, and subcontractors of each and any of them, for all losses and damages caused by, arising out of, relating to, or resulting from any of the perils or causes of loss covered by builder's risk insurance and any other property insurance applicable to the Work.

#### 6.07 Receipt and Application of Property Insurance Proceeds

- A. Any insured loss under the builder's risk and other policies of insurance required by Paragraph 6.05 will be adjusted and settled with the named insured that purchased the

policy. Such named insured shall act as fiduciary for the other insureds, and give notice to such other insureds that adjustment and settlement of a claim is in progress. Any other insured may state its position regarding a claim for insured loss in writing within 15 days after notice of such claim.

- B. Proceeds for such insured losses may be made payable by the insurer either jointly to multiple insureds, or to the named insured that purchased the policy in its own right and as fiduciary for other insureds, subject to the requirements of any applicable mortgage clause. A named insured receiving insurance proceeds under the builder's risk and other policies of insurance required by Paragraph 6.05 shall distribute such proceeds in accordance with such agreement as the parties in interest may reach, or as otherwise required under the dispute resolution provisions of this Contract or applicable Laws and Regulations.
- C. If no other special agreement is reached, the damaged Work shall be repaired or replaced, the money so received applied on account thereof, and the Work and the cost thereof covered by Change Order, if needed.

#### ARTICLE 7 – CONTRACTOR'S RESPONSIBILITIES

##### 7.01 *Supervision and Superintendence*

- A. Contractor shall supervise, inspect, and direct the Work competently and efficiently, devoting such attention thereto and applying such skills and expertise as may be necessary to perform the Work in accordance with the Contract Documents. Contractor shall be solely responsible for the means, methods, techniques, sequences, and procedures of construction.
- B. At all times during the progress of the Work, Contractor shall assign a competent resident superintendent who shall not be replaced without written notice to Owner and Engineer except under extraordinary circumstances.

##### 7.02 *Labor; Working Hours*

- A. Contractor shall provide competent, suitably qualified personnel to survey and lay out the Work and perform construction as required by the Contract Documents. Contractor shall at all times maintain good discipline and order at the Site.
- B. Except as otherwise required for the safety or protection of persons or the Work or property at the Site or adjacent thereto, and except as otherwise stated in the Contract Documents, all Work at the Site shall be performed during regular working hours, Monday through Friday. Contractor will not perform Work on a Saturday, Sunday, or any legal holiday. Contractor may perform Work outside regular working hours or on Saturdays, Sundays, or legal holidays only with Owner's written consent, which will not be unreasonably withheld.

##### 7.03 *Services, Materials, and Equipment*

- A. Unless otherwise specified in the Contract Documents, Contractor shall provide and assume full responsibility for all services, materials, equipment, labor, transportation, construction equipment and machinery, tools, appliances, fuel, power, light, heat, telephone, water, sanitary facilities, temporary facilities, and all other facilities and incidentals necessary for the performance, testing, start up, and completion of the Work, whether or not such items are specifically called for in the Contract Documents.
- B. All materials and equipment incorporated into the Work shall be of good quality and new, except as otherwise provided in the Contract Documents. All special warranties and

guarantees required by the Specifications shall expressly run to the benefit of Owner. If required by Engineer, Contractor shall furnish satisfactory evidence (including reports of required tests) as to the source, kind, and quality of materials and equipment.

- C. All materials and equipment shall be stored, applied, installed, connected, erected, protected, used, cleaned, and conditioned in accordance with instructions of the applicable Supplier, except as otherwise may be provided in the Contract Documents.

##### 7.04 *"Or Equals"*

- A. Whenever an item of material or equipment is specified or described in the Contract Documents by using the name of a proprietary item or the name of a particular Supplier, the Contract Price has been based upon Contractor furnishing such item as specified. The specification or description of such an item is intended to establish the type, function, appearance, and quality required. Unless the specification or description contains or is followed by words reading that no like, equivalent, or "or equal" item is permitted, Contractor may request that Engineer authorize the use of other items of material or equipment, or items from other proposed suppliers under the circumstances described below.

- 1. If Engineer in its sole discretion determines that an item of material or equipment proposed by Contractor is functionally equal to that named and sufficiently similar so that no change in related Work will be required, Engineer shall deem it an "or equal" item. For the purposes of this paragraph, a proposed item of material or equipment will be considered functionally equal to an item so named if:

- a. in the exercise of reasonable judgment Engineer determines that:

- 1) it is at least equal in materials of construction, quality, durability, appearance, strength, and design characteristics;
- 2) it will reliably perform at least equally well the function and achieve the results imposed by the design concept of the completed Project as a functioning whole;
- 3) it has a proven record of performance and availability of responsive service; and
- 4) it is not objectionable to Owner.

- b. Contractor certifies that, if approved and incorporated into the Work:

- 1) there will be no increase in cost to the Owner or increase in Contract Times; and
- 2) it will conform substantially to the detailed requirements of the item named in the Contract Documents.

- B. *Contractor's Expense:* Contractor shall provide all data in support of any proposed "or equal" item at Contractor's expense.

- C. *Engineer's Evaluation and Determination:* Engineer will be allowed a reasonable time to evaluate each "or-equal" request. Engineer may require Contractor to furnish additional data about the proposed "or-equal" item. Engineer will be the sole judge of acceptability. No "or-equal" item will be ordered, furnished, installed, or utilized until Engineer's review is complete and Engineer determines that the proposed item is an "or-equal", which will be evidenced by an approved Shop Drawing or other written communication. Engineer will advise Contractor in writing of any negative determination.

- D. *Effect of Engineer's Determination:* Neither approval nor denial of an "or-equal" request shall result in any change in Contract Price. The Engineer's denial of an "or-equal" request shall be final and binding, and may not be reversed through an appeal under any provision of the Contract Documents.
- E. *Treatment as a Substitution Request:* If Engineer determines that an item of material or equipment proposed by Contractor does not qualify as an "or-equal" item, Contractor may request that Engineer consider the proposed item as a substitute pursuant to Paragraph 7.05.

7.05 *Substitutes*

- A. Unless the specification or description of an item of material or equipment required to be furnished under the Contract Documents contains or is followed by words reading that no substitution is permitted, Contractor may request that Engineer authorize the use of other items of material or equipment under the circumstances described below. To the extent possible such requests shall be made before commencement of related construction at the Site.
  - 1. Contractor shall submit sufficient information as provided below to allow Engineer to determine if the item of material or equipment proposed is functionally equivalent to that named and an acceptable substitute therefor. Engineer will not accept requests for review of proposed substitute items of material or equipment from anyone other than Contractor.
  - 2. The requirements for review by Engineer will be as set forth in Paragraph 7.05.B, as supplemented by the Specifications, and as Engineer may decide is appropriate under the circumstances.
  - 3. Contractor shall make written application to Engineer for review of a proposed substitute item of material or equipment that Contractor seeks to furnish or use. The application:
    - a. shall certify that the proposed substitute item will:
      - 1) perform adequately the functions and achieve the results called for by the general design,
      - 2) be similar in substance to that specified, and
      - 3) be suited to the same use as that specified.
    - b. will state:
      - 1) the extent, if any, to which the use of the proposed substitute item will necessitate a change in Contract Times,
      - 2) whether use of the proposed substitute item in the Work will require a change in any of the Contract Documents (or in the provisions of any other direct contract with Owner for other work on the Project) to adapt the design to the proposed substitute item, and
      - 3) whether incorporation or use of the proposed substitute item in connection with the Work is subject to payment of any license fee or royalty.
    - c. will identify:
      - 1) all variations of the proposed substitute item from that specified, and

2) available engineering, sales, maintenance, repair, and replacement services.

- d. shall contain an itemized estimate of all costs or credits that will result directly or indirectly from use of such substitute item, including but not limited to changes in Contract Price, shared savings, costs of redesign, and claims of other contractors affected by any resulting change.

- B. *Engineer's Evaluation and Determination:* Engineer will be allowed a reasonable time to evaluate each substitute request, and to obtain comments and direction from Owner. Engineer may require Contractor to furnish additional data about the proposed substitute item. Engineer will be the sole judge of acceptability. No substitute will be ordered, furnished, installed, or utilized until Engineer's review is complete and Engineer determines that the proposed item is an acceptable substitute. Engineer's determination will be evidenced by a Field Order or a proposed Change Order accounting for the substitution itself and all related impacts, including changes in Contract Price or Contract Times. Engineer will advise Contractor in writing of any negative determination.
- C. *Special Guarantee:* Owner may require Contractor to furnish at Contractor's expense a special performance guarantee or other surety with respect to any substitute.
- D. *Reimbursement of Engineer's Cost:* Engineer will record Engineer's costs in evaluating a substitute proposed or submitted by Contractor. Whether or not Engineer approves a substitute so proposed or submitted by Contractor, Contractor shall reimburse Owner for the reasonable charges of Engineer for evaluating each such proposed substitute. Contractor shall also reimburse Owner for the reasonable charges of Engineer for making changes in the Contract Documents (or in the provisions of any other direct contract with Owner) resulting from the acceptance of each proposed substitute.
- E. *Contractor's Expense:* Contractor shall provide all data in support of any proposed substitute at Contractor's expense.
- F. *Effect of Engineer's Determination:* If Engineer approves the substitution request, Contractor shall execute the proposed Change Order and proceed with the substitution. The Engineer's denial of a substitution request shall be final and binding, and may not be reversed through an appeal under any provision of the Contract Documents. Contractor may challenge the scope of reimbursement costs imposed under Paragraph 7.05.D, by timely submittal of a Change Proposal.

7.06 *Concerning Subcontractors, Suppliers, and Others*

- A. Contractor may retain Subcontractors and Suppliers for the performance of parts of the Work. Such Subcontractors and Suppliers must be acceptable to Owner.
- B. Contractor shall retain specific Subcontractors, Suppliers, or other individuals or entities for the performance of designated parts of the Work if required by the Contract to do so.
- C. Subsequent to the submittal of Contractor's Bid or final negotiation of the terms of the Contract, Owner may not require Contractor to retain any Subcontractor, Supplier, or other individual or entity to furnish or perform any of the Work against which Contractor has reasonable objection.
- D. Prior to entry into any binding subcontract or purchase order, Contractor shall submit to Owner the identity of the proposed Subcontractor or Supplier (unless Owner has already deemed such proposed Subcontractor or Supplier acceptable, during the bidding process or otherwise). Such proposed Subcontractor or Supplier shall be deemed acceptable to Owner unless Owner raises a substantive, reasonable objection within five days.

- E. Owner may require the replacement of any Subcontractor, Supplier, or other individual or entity retained by Contractor to perform any part of the Work. Owner also may require Contractor to retain specific replacements; provided, however, that Owner may not require a replacement to which Contractor has a reasonable objection. If Contractor has submitted the identity of certain Subcontractors, Suppliers, or other individuals or entities for acceptance by Owner, and Owner has accepted it (either in writing or by failing to make written objection thereto), then Owner may subsequently revoke the acceptance of any such Subcontractor, Supplier, or other individual or entity so identified solely on the basis of substantive, reasonable objection after due investigation. Contractor shall submit an acceptable replacement for the rejected Subcontractor, Supplier, or other individual or entity.
- F. If Owner requires the replacement of any Subcontractor, Supplier, or other individual or entity retained by Contractor to perform any part of the Work, then Contractor shall be entitled to an adjustment in Contract Price or Contract Times, or both, with respect to the replacement; and Contractor shall initiate a Change Proposal for such adjustment within 30 days of Owner's requirement of replacement.
- G. No acceptance by Owner of any such Subcontractor, Supplier, or other individual or entity, whether initially or as a replacement, shall constitute a waiver of the right of Owner to the completion of the Work in accordance with the Contract Documents.
- H. On a monthly basis Contractor shall submit to Engineer a complete list of all Subcontractors and Suppliers having a direct contract with Contractor, and of all other Subcontractors and Suppliers known to Contractor at the time of submittal.
- I. Contractor shall be fully responsible to Owner and Engineer for all acts and omissions of the Subcontractors, Suppliers, and other individuals or entities performing or furnishing any of the Work just as Contractor is responsible for Contractor's own acts and omissions.
- J. Contractor shall be solely responsible for scheduling and coordinating the work of Subcontractors, Suppliers, and all other individuals or entities performing or furnishing any of the Work.
- K. Contractor shall restrict all Subcontractors, Suppliers, and such other individuals or entities performing or furnishing any of the Work from communicating with Engineer or Owner, except through Contractor or in case of an emergency, or as otherwise expressly allowed herein.
- L. The divisions and sections of the Specifications and the identifications of any Drawings shall not control Contractor in dividing the Work among Subcontractors or Suppliers or delineating the Work to be performed by any specific trade.
- M. All Work performed for Contractor by a Subcontractor or Supplier shall be pursuant to an appropriate contractual agreement that specifically binds the Subcontractor or Supplier to the applicable terms and conditions of the Contract Documents for the benefit of Owner and Engineer.
- N. Owner may furnish to any Subcontractor or Supplier, to the extent practicable, information about amounts paid to Contractor on account of Work performed for Contractor by the particular Subcontractor or Supplier.

O. Nothing in the Contract Documents:

- 1. shall create for the benefit of any such Subcontractor, Supplier, or other individual or entity any contractual relationship between Owner or Engineer and any such Subcontractor, Supplier, or other individual or entity; nor
- 2. shall create any obligation on the part of Owner or Engineer to pay or to see to the payment of any money due any such Subcontractor, Supplier, or other individual or entity except as may otherwise be required by Laws and Regulations.

7.07 Patent Fees and Royalties

- A. Contractor shall pay all license fees and royalties and assume all costs incident to the use in the performance of the Work or the incorporation in the Work of any invention, design, process, product, or device which is the subject of patent rights or copyrights held by others. If a particular invention, design, process, product, or device is specified in the Contract Documents for use in the performance of the Work and if, to the actual knowledge of Owner or Engineer, its use is subject to patent rights or copyrights calling for the payment of any license fee or royalty to others, the existence of such rights shall be disclosed by Owner in the Contract Documents.
- B. To the fullest extent permitted by Laws and Regulations, Owner shall indemnify and hold harmless Contractor, and its officers, directors, members, partners, employees, agents, consultants, and subcontractors from and against all claims, costs, losses, and damages (including but not limited to all fees and charges of engineers, architects, attorneys, and other professionals, and all court or arbitration or other dispute resolution costs) arising out of or relating to any infringement of patent rights or copyrights incident to the use in the performance of the Work or resulting from the incorporation in the Work of any invention, design, process, product, or device specified in the Contract Documents, but not identified as being subject to payment of any license fee or royalty to others required by patent rights or copyrights.
- C. To the fullest extent permitted by Laws and Regulations, Contractor shall indemnify and hold harmless Owner and Engineer, and the officers, directors, members, partners, employees, agents, consultants and subcontractors of each and any of them from and against all claims, costs, losses, and damages (including but not limited to all fees and charges of engineers, architects, attorneys, and other professionals and all court or arbitration or other dispute resolution costs) arising out of or relating to any infringement of patent rights or copyrights incident to the use in the performance of the Work or resulting from the incorporation in the Work of any invention, design, process, product, or device not specified in the Contract Documents.

7.08 Permits

- A. Unless otherwise provided in the Contract Documents, Contractor shall obtain and pay for all construction permits and licenses. Owner shall assist Contractor, when necessary, in obtaining such permits and licenses. Contractor shall pay all governmental charges and inspection fees necessary for the prosecution of the Work which are applicable at the time of the submission of Contractor's Bid (or when Contractor became bound under a negotiated contract). Owner shall pay all charges of utility owners for connections for providing permanent service to the Work

7.09 *Taxes*

- A. Contractor shall pay all sales, consumer, use, and other similar taxes required to be paid by Contractor in accordance with the Laws and Regulations of the place of the Project which are applicable during the performance of the Work.

7.10 *Laws and Regulations*

- A. Contractor shall give all notices required by and shall comply with all Laws and Regulations applicable to the performance of the Work. Except where otherwise expressly required by applicable Laws and Regulations, neither Owner nor Engineer shall be responsible for monitoring Contractor's compliance with any Laws or Regulations.
- B. If Contractor performs any Work or takes any other action knowing or having reason to know that it is contrary to Laws or Regulations, Contractor shall bear all resulting costs and losses, and shall indemnify and hold harmless Owner and Engineer, and the officers, directors, members, partners, employees, agents, consultants, and subcontractors of each and any of them from and against all claims, costs, losses, and damages (including but not limited to all fees and charges of engineers, architects, attorneys, and other professionals and all court or arbitration or other dispute resolution costs) arising out of or relating to such Work or other action. It shall not be Contractor's responsibility to make certain that the Work described in the Contract Documents is in accordance with Laws and Regulations, but this shall not relieve Contractor of Contractor's obligations under Paragraph 3.03.
- C. Owner or Contractor may give notice to the other party of any changes after the submission of Contractor's Bid (or after the date when Contractor became bound under a negotiated contract) in Laws or Regulations having an effect on the cost or time of performance of the Work, including but not limited to changes in Laws or Regulations having an effect on procuring permits and on sales, use, value-added, consumption, and other similar taxes. If Owner and Contractor are unable to agree on entitlement to or on the amount or extent, if any, of any adjustment in Contract Price or Contract Times resulting from such changes, then within 30 days of such notice Contractor may submit a Change Proposal, or Owner may initiate a Claim.

7.11 *Record Documents*

- A. Contractor shall maintain in a safe place at the Site one printed record copy of all Drawings, Specifications, Addenda, Change Orders, Work Change Directives, Field Orders, written interpretations and clarifications, and approved Shop Drawings. Contractor shall keep such record documents in good order and annotate them to show changes made during construction. These record documents, together with all approved Samples, will be available to Engineer for reference. Upon completion of the Work, Contractor shall deliver these record documents to Engineer.

7.12 *Safety and Protection*

- A. Contractor shall be solely responsible for initiating, maintaining, and supervising all safety precautions and programs in connection with the Work. Such responsibility does not relieve Subcontractors of their responsibility for the safety of persons or property in the performance of their work, nor for compliance with applicable safety Laws and Regulations. Contractor shall take all necessary precautions for the safety of, and shall provide the necessary protection to prevent damage, injury, or loss to:
  1. all persons on the Site or who may be affected by the Work;

2. all the Work and materials and equipment to be incorporated therein, whether in storage on or off the Site; and
3. other property at the Site or adjacent thereto, including trees, shrubs, lawns, walks, pavements, roadways, structures, other work in progress, utilities, and Underground Facilities not designated for removal, relocation, or replacement in the course of construction.

- B. Contractor shall comply with all applicable Laws and Regulations relating to the safety of persons or property, or to the protection of persons or property from damage, injury, or loss; and shall erect and maintain all necessary safeguards for such safety and protection. Contractor shall notify Owner; the owners of adjacent property, Underground Facilities, and other utilities; and other contractors and utility owners performing work at or adjacent to the Site, when prosecution of the Work may affect them, and shall cooperate with them in the protection, removal, relocation, and replacement of their property or work in progress.
- C. Contractor shall comply with the applicable requirements of Owner's safety programs, if any. The Supplementary Conditions identify any Owner's safety programs that are applicable to the Work.
- D. Contractor shall inform Owner and Engineer of the specific requirements of Contractor's safety program with which Owner's and Engineer's employees and representatives must comply while at the Site.
- E. All damage, injury, or loss to any property referred to in Paragraph 7.12.A.2 or 7.12.A.3 caused, directly or indirectly, in whole or in part, by Contractor, any Subcontractor, Supplier, or any other individual or entity directly or indirectly employed by any of them to perform any of the Work, or anyone for whose acts any of them may be liable, shall be remedied by Contractor at its expense (except damage or loss attributable to the fault of Drawings or Specifications or to the acts or omissions of Owner or Engineer or anyone employed by any of them, or anyone for whose acts any of them may be liable, and not attributable, directly or indirectly, in whole or in part, to the fault or negligence of Contractor or any Subcontractor, Supplier, or other individual or entity directly or indirectly employed by any of them).
- F. Contractor's duties and responsibilities for safety and protection shall continue until such time as all the Work is completed and Engineer has issued a notice to Owner and Contractor in accordance with Paragraph 15.06.B that the Work is acceptable (except as otherwise expressly provided in connection with Substantial Completion).
- G. Contractor's duties and responsibilities for safety and protection shall resume whenever Contractor or any Subcontractor or Supplier returns to the Site to fulfill warranty or correction obligations, or to conduct other tasks arising from the Contract Documents.

7.13 *Safety Representative*

- A. Contractor shall designate a qualified and experienced safety representative at the Site whose duties and responsibilities shall be the prevention of accidents and the maintaining and supervising of safety precautions and programs.

7.14 *Hazard Communication Programs*

- A. Contractor shall be responsible for coordinating any exchange of material safety data sheets or other hazard communication information required to be made available to or

exchanged between or among employers at the Site in accordance with Laws or Regulations.

7.15 *Emergencies*

- A. In emergencies affecting the safety or protection of persons or the Work or property at the Site or adjacent thereto, Contractor is obligated to act to prevent threatened damage, injury, or loss. Contractor shall give Engineer prompt written notice if Contractor believes that any significant changes in the Work or variations from the Contract Documents have been caused thereby or are required as a result thereof. If Engineer determines that a change in the Contract Documents is required because of the action taken by Contractor in response to such an emergency, a Work Change Directive or Change Order will be issued.

7.16 *Shop Drawings, Samples, and Other Submittals*

A. *Shop Drawing and Sample Submittal Requirements:*

1. Before submitting a Shop Drawing or Sample, Contractor shall have:
  - a. reviewed and coordinated the Shop Drawing or Sample with other Shop Drawings and Samples and with the requirements of the Work and the Contract Documents;
  - b. determined and verified all field measurements, quantities, dimensions, specified performance and design criteria, installation requirements, materials, catalog numbers, and similar information with respect thereto;
  - c. determined and verified the suitability of all materials and equipment offered with respect to the indicated application, fabrication, shipping, handling, storage, assembly, and installation pertaining to the performance of the Work; and
  - d. determined and verified all information relative to Contractor's responsibilities for means, methods, techniques, sequences, and procedures of construction, and safety precautions and programs incident thereto.
2. Each submittal shall bear a stamp or specific written certification that Contractor has satisfied Contractor's obligations under the Contract Documents with respect to Contractor's review of that submittal, and that Contractor approves the submittal.
3. With each submittal, Contractor shall give Engineer specific written notice of any variations that the Shop Drawing or Sample may have from the requirements of the Contract Documents. This notice shall be set forth in a written communication separate from the Shop Drawings or Sample submittal; and, in addition, in the case of Shop Drawings by a specific notation made on each Shop Drawing submitted to Engineer for review and approval of each such variation.

- B. *Submittal Procedures for Shop Drawings and Samples:* Contractor shall submit Shop Drawings and Samples to Engineer for review and approval in accordance with the accepted Schedule of Submittals. Each submittal will be identified as Engineer may require.

1. *Shop Drawings:*

- a. Contractor shall submit the number of copies required in the Specifications.
- b. Data shown on the Shop Drawings will be complete with respect to quantities, dimensions, specified performance and design criteria, materials, and similar data to show Engineer the services, materials, and equipment Contractor proposes to

provide and to enable Engineer to review the information for the limited purposes required by Paragraph 7.16.D.

2. *Samples:*

- a. Contractor shall submit the number of Samples required in the Specifications.
- b. Contractor shall clearly identify each Sample as to material, Supplier, pertinent data such as catalog numbers, the use for which intended and other data as Engineer may require to enable Engineer to review the submittal for the limited purposes required by Paragraph 7.16.D.

3. Where a Shop Drawing or Sample is required by the Contract Documents or the Schedule of Submittals, any related Work performed prior to Engineer's review and approval of the pertinent submittal will be at the sole expense and responsibility of Contractor.

- C. *Other Submittals:* Contractor shall submit other submittals to Engineer in accordance with the accepted Schedule of Submittals, and pursuant to the applicable terms of the Specifications.

D. *Engineer's Review:*

1. Engineer will provide timely review of Shop Drawings and Samples in accordance with the Schedule of Submittals acceptable to Engineer. Engineer's review and approval will be only to determine if the items covered by the submittals will, after installation or incorporation in the Work, conform to the information given in the Contract Documents and be compatible with the design concept of the completed Project as a functioning whole as indicated by the Contract Documents.
2. Engineer's review and approval will not extend to means, methods, techniques, sequences, or procedures of construction or to safety precautions or programs incident thereto.
3. Engineer's review and approval of a separate item as such will not indicate approval of the assembly in which the item functions.
4. Engineer's review and approval of a Shop Drawing or Sample shall not relieve Contractor from responsibility for any variation from the requirements of the Contract Documents unless Contractor has complied with the requirements of Paragraph 7.16.A.3 and Engineer has given written approval of each such variation by specific written notation thereof incorporated in or accompanying the Shop Drawing or Sample. Engineer will document any such approved variation from the requirements of the Contract Documents in a Field Order.
5. Engineer's review and approval of a Shop Drawing or Sample shall not relieve Contractor from responsibility for complying with the requirements of Paragraph 7.16.A and B.
6. Engineer's review and approval of a Shop Drawing or Sample, or of a variation from the requirements of the Contract Documents, shall not, under any circumstances, change the Contract Times or Contract Price, unless such changes are included in a Change Order.
7. Neither Engineer's receipt, review, acceptance or approval of a Shop Drawing, Sample, or other submittal shall result in such item becoming a Contract Document.



8. Contractor shall perform the Work in compliance with the requirements and commitments set forth in approved Shop Drawings and Samples, subject to the provisions of Paragraph 7.16.D.4.

E. *Resubmittal Procedures:*

1. Contractor shall make corrections required by Engineer and shall return the required number of corrected copies of Shop Drawings and submit, as required, new Samples for review and approval. Contractor shall direct specific attention in writing to revisions other than the corrections called for by Engineer on previous submittals.
2. Contractor shall furnish required submittals with sufficient information and accuracy to obtain required approval of an item with no more than three submittals. Engineer will record Engineer's time for reviewing a fourth or subsequent submittal of a Shop Drawings, sample, or other item requiring approval, and Contractor shall be responsible for Engineer's charges to Owner for such time. Owner may impose a set-off against payments due to Contractor to secure reimbursement for such charges.
3. If Contractor requests a change of a previously approved submittal item, Contractor shall be responsible for Engineer's charges to Owner for its review time, and Owner may impose a set-off against payments due to Contractor to secure reimbursement for such charges, unless the need for such change is beyond the control of Contractor.

7.17 *Contractor's General Warranty and Guarantee*

- A. Contractor warrants and guarantees to Owner that all Work will be in accordance with the Contract Documents and will not be defective. Engineer and its officers, directors, members, partners, employees, agents, consultants, and subcontractors shall be entitled to rely on Contractor's warranty and guarantee.
- B. Contractor's warranty and guarantee hereunder excludes defects or damage caused by:
  1. abuse, modification, or improper maintenance or operation by persons other than Contractor, Subcontractors, Suppliers, or any other individual or entity for whom Contractor is responsible; or
  2. normal wear and tear under normal usage.
- C. Contractor's obligation to perform and complete the Work in accordance with the Contract Documents shall be absolute. None of the following will constitute an acceptance of Work that is not in accordance with the Contract Documents or a release of Contractor's obligation to perform the Work in accordance with the Contract Documents:
  1. observations by Engineer;
  2. recommendation by Engineer or payment by Owner of any progress or final payment;
  3. the issuance of a certificate of Substantial Completion by Engineer or any payment related thereto by Owner;
  4. use or occupancy of the Work or any part thereof by Owner;
  5. any review and approval of a Shop Drawing or Sample submittal;
  6. the issuance of a notice of acceptability by Engineer;
  7. any inspection, test, or approval by others; or
  8. any correction of defective Work by Owner.

- D. If the Contract requires the Contractor to accept the assignment of a contract entered into by Owner, then the specific warranties, guarantees, and correction obligations contained in the assigned contract shall govern with respect to Contractor's performance obligations to Owner for the Work described in the assigned contract.

7.18 *Indemnification*

- A. To the fullest extent permitted by Laws and Regulations, and in addition to any other obligations of Contractor under the Contract or otherwise, Contractor shall indemnify and hold harmless Owner and Engineer, and the officers, directors, members, partners, employees, agents, consultants and subcontractors of each and any of them from and against all claims, costs, losses, and damages (including but not limited to all fees and charges of engineers, architects, attorneys, and other professionals and all court or arbitration or other dispute resolution costs) arising out of or relating to the performance of the Work, provided that any such claim, cost, loss, or damage is attributable to bodily injury, sickness, disease, or death, or to injury to or destruction of tangible property (other than the Work itself), including the loss of use resulting therefrom but only to the extent caused by any negligent act or omission of Contractor, any Subcontractor, any Supplier, or any individual or entity directly or indirectly employed by any of them to perform any of the Work or anyone for whose acts any of them may be liable.
- B. In any and all claims against Owner or Engineer or any of their officers, directors, members, partners, employees, agents, consultants, or subcontractors by any employee (or the survivor or personal representative of such employee) of Contractor, any Subcontractor, any Supplier, or any individual or entity directly or indirectly employed by any of them to perform any of the Work, or anyone for whose acts any of them may be liable, the indemnification obligation under Paragraph 7.18.A shall not be limited in any way by any limitation on the amount or type of damages, compensation, or benefits payable by or for Contractor or any such Subcontractor, Supplier, or other individual or entity under workers' compensation acts, disability benefit acts, or other employee benefit acts.
- C. The indemnification obligations of Contractor under Paragraph 7.18.A shall not extend to the liability of Engineer and Engineer's officers, directors, members, partners, employees, agents, consultants and subcontractors arising out of:
  1. the preparation or approval of, or the failure to prepare or approve maps, Drawings, opinions, reports, surveys, Change Orders, designs, or Specifications; or
  2. giving directions or instructions, or failing to give them, if that is the primary cause of the injury or damage.

7.19 *Delegation of Professional Design Services*

- A. Contractor will not be required to provide professional design services unless such services are specifically required by the Contract Documents for a portion of the Work or unless such services are required to carry out Contractor's responsibilities for construction means, methods, techniques, sequences and procedures. Contractor shall not be required to provide professional services in violation of applicable Laws and Regulations.
- B. If professional design services or certifications by a design professional related to systems, materials, or equipment are specifically required of Contractor by the Contract Documents, Owner and Engineer will specify all performance and design criteria that such services must satisfy. Contractor shall cause such services or certifications to be provided by a properly licensed professional, whose signature and seal shall appear on all drawings, calculations, specifications, certifications, and other submittals prepared by such professional. Shop

Drawings and other submittals related to the Work designed or certified by such professional, if prepared by others, shall bear such professional's written approval when submitted to Engineer.

- C. Owner and Engineer shall be entitled to rely upon the adequacy, accuracy, and completeness of the services, certifications, or approvals performed by such design professionals, provided Owner and Engineer have specified to Contractor all performance and design criteria that such services must satisfy.
- D. Pursuant to this paragraph, Engineer's review and approval of design calculations and design drawings will be only for the limited purpose of checking for conformance with performance and design criteria given and the design concept expressed in the Contract Documents. Engineer's review and approval of Shop Drawings and other submittals (except design calculations and design drawings) will be only for the purpose stated in Paragraph 7.16.D.1.
- E. Contractor shall not be responsible for the adequacy of the performance or design criteria specified by Owner or Engineer.

#### ARTICLE 8 – OTHER WORK AT THE SITE

##### 8.01 Other Work

- A. In addition to and apart from the Work under the Contract Documents, the Owner may perform other work at or adjacent to the Site. Such other work may be performed by Owner's employees, or through contracts between the Owner and third parties. Owner may also arrange to have third-party utility owners perform work on their utilities and facilities at or adjacent to the Site.
- B. If Owner performs other work at or adjacent to the Site with Owner's employees, or through contracts for such other work, then Owner shall give Contractor written notice thereof prior to starting any such other work. If Owner has advance information regarding the start of any utility work at or adjacent to the Site, Owner shall provide such information to Contractor.
- C. Contractor shall afford each other contractor that performs such other work, each utility owner performing other work, and Owner, if Owner is performing other work with Owner's employees, proper and safe access to the Site, and provide a reasonable opportunity for the introduction and storage of materials and equipment and the execution of such other work. Contractor shall do all cutting, fitting, and patching of the Work that may be required to properly connect or otherwise make its several parts come together and properly integrate with such other work. Contractor shall not endanger any work of others by cutting, excavating, or otherwise altering such work; provided, however, that Contractor may cut or alter others' work with the written consent of Engineer and the others whose work will be affected.
- D. If the proper execution or results of any part of Contractor's Work depends upon work performed by others under this Article 8, Contractor shall inspect such other work and promptly report to Engineer in writing any delays, defects, or deficiencies in such other work that render it unavailable or unsuitable for the proper execution and results of Contractor's Work. Contractor's failure to so report will constitute an acceptance of such other work as fit and proper for integration with Contractor's Work except for latent defects and deficiencies in such other work.

##### 8.02 Coordination

- A. If Owner intends to contract with others for the performance of other work at or adjacent to the Site, to perform other work at or adjacent to the Site with Owner's employees, or to arrange to have utility owners perform work at or adjacent to the Site, the following will be set forth in the Supplementary Conditions or provided to Contractor prior to the start of any such other work:
  - 1. the identity of the individual or entity that will have authority and responsibility for coordination of the activities among the various contractors;
  - 2. an itemization of the specific matters to be covered by such authority and responsibility; and
  - 3. the extent of such authority and responsibilities.
- B. Unless otherwise provided in the Supplementary Conditions, Owner shall have sole authority and responsibility for such coordination.

##### 8.03 Legal Relationships

- A. If, in the course of performing other work at or adjacent to the Site for Owner, the Owner's employees, any other contractor working for Owner, or any utility owner for whom the Owner is responsible causes damage to the Work or to the property of Contractor or its Subcontractors, or delays, disrupts, interferes with, or increases the scope or cost of the performance of the Work, through actions or inaction, then Contractor shall be entitled to an equitable adjustment in the Contract Price or the Contract Times, or both. Contractor must submit any Change Proposal seeking an equitable adjustment in the Contract Price or the Contract Times under this paragraph within 30 days of the damaging, delaying, disrupting, or interfering event. The entitlement to, and extent of, any such equitable adjustment shall take into account information (if any) regarding such other work that was provided to Contractor in the Contract Documents prior to the submittal of the Bid or the final negotiation of the terms of the Contract. When applicable, any such equitable adjustment in Contract Price shall be conditioned on Contractor assigning to Owner all Contractor's rights against such other contractor or utility owner with respect to the damage, delay, disruption, or interference that is the subject of the adjustment. Contractor's entitlement to an adjustment of the Contract Times is conditioned on such adjustment being essential to Contractor's ability to complete the Work within the Contract Times.
- B. Contractor shall take reasonable and customary measures to avoid damaging, delaying, disrupting, or interfering with the work of Owner, any other contractor, or any utility owner performing other work at or adjacent to the Site. If Contractor fails to take such measures and as a result damages, delays, disrupts, or interferes with the work of any such other contractor or utility owner, then Owner may impose a set-off against payments due to Contractor, and assign to such other contractor or utility owner the Owner's contractual rights against Contractor with respect to the breach of the obligations set forth in this paragraph.
- C. When Owner is performing other work at or adjacent to the Site with Owner's employees, Contractor shall be liable to Owner for damage to such other work, and for the reasonable direct delay, disruption, and interference costs incurred by Owner as a result of Contractor's failure to take reasonable and customary measures with respect to Owner's other work. In response to such damage, delay, disruption, or interference, Owner may impose a set-off against payments due to Contractor.

- D. If Contractor damages, delays, disrupts, or interferes with the work of any other contractor, or any utility owner performing other work at or adjacent to the Site, through Contractor's failure to take reasonable and customary measures to avoid such impacts, or if any claim arising out of Contractor's actions, inactions, or negligence in performance of the Work at or adjacent to the Site is made by any such other contractor or utility owner against Contractor, Owner, or Engineer, then Contractor shall (1) promptly attempt to settle the claim as to all parties through negotiations with such other contractor or utility owner, or otherwise resolve the claim by arbitration or other dispute resolution proceeding or at law, and (2) indemnify and hold harmless Owner and Engineer, and the officers, directors, members, partners, employees, agents, consultants and subcontractors of each and any of them from and against any such claims, and against all costs, losses, and damages (including but not limited to all fees and charges of engineers, architects, attorneys, and other professionals and all court or arbitration or other dispute resolution costs) arising out of or relating to such damage, delay, disruption, or interference.

#### ARTICLE 9 – OWNER'S RESPONSIBILITIES

##### 9.01 *Communications to Contractor*

- A. Except as otherwise provided in these General Conditions, Owner shall issue all communications to Contractor through Engineer.

##### 9.02 *Replacement of Engineer*

- A. Owner may at its discretion appoint an engineer to replace Engineer, provided Contractor makes no reasonable objection to the replacement engineer. The replacement engineer's status under the Contract Documents shall be that of the former Engineer.

##### 9.03 *Furnish Data*

- A. Owner shall promptly furnish the data required of Owner under the Contract Documents.

##### 9.04 *Pay When Due*

- A. Owner shall make payments to Contractor when they are due as provided in the Agreement.

##### 9.05 *Lands and Easements; Reports, Tests, and Drawings*

- A. Owner's duties with respect to providing lands and easements are set forth in Paragraph 5.01.  
B. Owner's duties with respect to providing engineering surveys to establish reference points are set forth in Paragraph 4.03.  
C. Article 5 refers to Owner's identifying and making available to Contractor copies of reports of explorations and tests of conditions at the Site, and drawings of physical conditions relating to existing surface or subsurface structures at the Site.

##### 9.06 *Insurance*

- A. Owner's responsibilities, if any, with respect to purchasing and maintaining liability and property insurance are set forth in Article 6.

##### 9.07 *Change Orders*

- A. Owner's responsibilities with respect to Change Orders are set forth in Article 11.

##### 9.08 *Inspections, Tests, and Approvals*

- A. Owner's responsibility with respect to certain inspections, tests, and approvals is set forth in Paragraph 14.02.B.

##### 9.09 *Limitations on Owner's Responsibilities*

- A. The Owner shall not supervise, direct, or have control or authority over, nor be responsible for, Contractor's means, methods, techniques, sequences, or procedures of construction, or the safety precautions and programs incident thereto, or for any failure of Contractor to comply with Laws and Regulations applicable to the performance of the Work. Owner will not be responsible for Contractor's failure to perform the Work in accordance with the Contract Documents.

##### 9.10 *Undisclosed Hazardous Environmental Condition*

- A. Owner's responsibility in respect to an undisclosed Hazardous Environmental Condition is set forth in Paragraph 5.06.

##### 9.11 *Evidence of Financial Arrangements*

- A. Upon request of Contractor, Owner shall furnish Contractor reasonable evidence that financial arrangements have been made to satisfy Owner's obligations under the Contract Documents (including obligations under proposed changes in the Work).

##### 9.12 *Safety Programs*

- A. While at the Site, Owner's employees and representatives shall comply with the specific applicable requirements of Contractor's safety programs of which Owner has been informed.  
B. Owner shall furnish copies of any applicable Owner safety programs to Contractor.

#### ARTICLE 10 – ENGINEER'S STATUS DURING CONSTRUCTION

##### 10.01 *Owner's Representative*

- A. Engineer will be Owner's representative during the construction period. The duties and responsibilities and the limitations of authority of Engineer as Owner's representative during construction are set forth in the Contract.

##### 10.02 *Visits to Site*

- A. Engineer will make visits to the Site at intervals appropriate to the various stages of construction as Engineer deems necessary in order to observe as an experienced and qualified design professional the progress that has been made and the quality of the various aspects of Contractor's executed Work. Based on information obtained during such visits and observations, Engineer, for the benefit of Owner, will determine, in general, if the Work is proceeding in accordance with the Contract Documents. Engineer will not be required to make exhaustive or continuous inspections on the Site to check the quality or quantity of the Work. Engineer's efforts will be directed toward providing for Owner a greater degree of confidence that the completed Work will conform generally to the Contract Documents. On the basis of such visits and observations, Engineer will keep Owner informed of the progress of the Work and will endeavor to guard Owner against defective Work.  
B. Engineer's visits and observations are subject to all the limitations on Engineer's authority and responsibility set forth in Paragraph 10.08. Particularly, but without limitation, during

or as a result of Engineer's visits or observations of Contractor's Work, Engineer will not supervise, direct, control, or have authority over or be responsible for Contractor's means, methods, techniques, sequences, or procedures of construction, or the safety precautions and programs incident thereto, or for any failure of Contractor to comply with Laws and Regulations applicable to the performance of the Work.

#### 10.03 *Project Representative*

- A. If Owner and Engineer have agreed that Engineer will furnish a Resident Project Representative to represent Engineer at the Site and assist Engineer in observing the progress and quality of the Work, then the authority and responsibilities of any such Resident Project Representative will be as provided in the Supplementary Conditions, and limitations on the responsibilities thereof will be as provided in Paragraph 10.08. If Owner designates another representative or agent to represent Owner at the Site who is not Engineer's consultant, agent, or employee, the responsibilities and authority and limitations thereon of such other individual or entity will be as provided in the Supplementary Conditions.

#### 10.04 *Rejecting Defective Work*

- A. Engineer has the authority to reject Work in accordance with Article 14.

#### 10.05 *Shop Drawings, Change Orders and Payments*

- A. Engineer's authority, and limitations thereof, as to Shop Drawings and Samples, are set forth in Paragraph 7.16.
- B. Engineer's authority, and limitations thereof, as to design calculations and design drawings submitted in response to a delegation of professional design services, if any, are set forth in Paragraph 7.19.
- C. Engineer's authority as to Change Orders is set forth in Article 11.
- D. Engineer's authority as to Applications for Payment is set forth in Article 15.

#### 10.06 *Determinations for Unit Price Work*

- A. Engineer will determine the actual quantities and classifications of Unit Price Work performed by Contractor as set forth in Paragraph 13.03.

#### 10.07 *Decisions on Requirements of Contract Documents and Acceptability of Work*

- A. Engineer will render decisions regarding the requirements of the Contract Documents, and judge the acceptability of the Work, pursuant to the specific procedures set forth herein for initial interpretations, Change Proposals, and acceptance of the Work. In rendering such decisions and judgments, Engineer will not show partiality to Owner or Contractor, and will not be liable to Owner, Contractor, or others in connection with any proceedings, interpretations, decisions, or judgments conducted or rendered in good faith.

#### 10.08 *Limitations on Engineer's Authority and Responsibilities*

- A. Neither Engineer's authority or responsibility under this Article 10 or under any other provision of the Contract, nor any decision made by Engineer in good faith either to exercise or not exercise such authority or responsibility or the undertaking, exercise, or performance of any authority or responsibility by Engineer, shall create, impose, or give rise to any duty in contract, tort, or otherwise owed by Engineer to Contractor, any Subcontractor, any Supplier, any other individual or entity, or to any surety for or employee or agent of any of them.

- B. Engineer will not supervise, direct, control, or have authority over or be responsible for Contractor's means, methods, techniques, sequences, or procedures of construction, or the safety precautions and programs incident thereto, or for any failure of Contractor to comply with Laws and Regulations applicable to the performance of the Work. Engineer will not be responsible for Contractor's failure to perform the Work in accordance with the Contract Documents.
- C. Engineer will not be responsible for the acts or omissions of Contractor or of any Subcontractor, any Supplier, or of any other individual or entity performing any of the Work.
- D. Engineer's review of the final Application for Payment and accompanying documentation and all maintenance and operating instructions, schedules, guarantees, bonds, certificates of inspection, tests and approvals, and other documentation required to be delivered by Paragraph 15.06.A will only be to determine generally that their content complies with the requirements of, and in the case of certificates of inspections, tests, and approvals, that the results certified indicate compliance with the Contract Documents.
- E. The limitations upon authority and responsibility set forth in this Paragraph 10.08 shall also apply to the Resident Project Representative, if any.

#### 10.09 *Compliance with Safety Program*

- A. While at the Site, Engineer's employees and representatives will comply with the specific applicable requirements of Owner's and Contractor's safety programs (if any) of which Engineer has been informed.

### ARTICLE 11 – AMENDING THE CONTRACT DOCUMENTS; CHANGES IN THE WORK

#### 11.01 *Amending and Supplementing Contract Documents*

- A. The Contract Documents may be amended or supplemented by a Change Order, a Work Change Directive, or a Field Order.

##### 1. *Change Orders:*

- a. If an amendment or supplement to the Contract Documents includes a change in the Contract Price or the Contract Times, such amendment or supplement must be set forth in a Change Order. A Change Order also may be used to establish amendments and supplements of the Contract Documents that do not affect the Contract Price or Contract Times.

- b. Owner and Contractor may amend those terms and conditions of the Contract Documents that do not involve (1) the performance or acceptability of the Work, (2) the design (as set forth in the Drawings, Specifications, or otherwise), or (3) other engineering or technical matters, without the recommendation of the Engineer. Such an amendment shall be set forth in a Change Order.

2. *Work Change Directives:* A Work Change Directive will not change the Contract Price or the Contract Times but is evidence that the parties expect that the modification ordered or documented by a Work Change Directive will be incorporated in a subsequently issued Change Order, following negotiations by the parties as to the Work Change Directive's effect, if any, on the Contract Price and Contract Times; or, if negotiations are unsuccessful, by a determination under the terms of the Contract Documents governing adjustments, expressly including Paragraph 11.04 regarding change of Contract Price. Contractor must submit any Change Proposal seeking an

adjustment of the Contract Price or the Contract Times, or both, no later than 30 days after the completion of the Work set out in the Work Change Directive. Owner must submit any Claim seeking an adjustment of the Contract Price or the Contract Times, or both, no later than 60 days after issuance of the Work Change Directive.

3. *Field Orders:* Engineer may authorize minor changes in the Work if the changes do not involve an adjustment in the Contract Price or the Contract Times and are compatible with the design concept of the completed Project as a functioning whole as indicated by the Contract Documents. Such changes will be accomplished by a Field Order and will be binding on Owner and also on Contractor, which shall perform the Work involved promptly. If Contractor believes that a Field Order justifies an adjustment in the Contract Price or Contract Times, or both, then before proceeding with the Work at issue, Contractor shall submit a Change Proposal as provided herein.

#### 11.02 *Owner-Authorized Changes in the Work*

- A. Without invalidating the Contract and without notice to any surety, Owner may, at any time or from time to time, order additions, deletions, or revisions in the Work. Such changes shall be supported by Engineer's recommendation, to the extent the change involves the design (as set forth in the Drawings, Specifications, or otherwise), or other engineering or technical matters. Such changes may be accomplished by a Change Order, if Owner and Contractor have agreed as to the effect, if any, of the changes on Contract Times or Contract Price; or by a Work Change Directive. Upon receipt of any such document, Contractor shall promptly proceed with the Work involved; or, in the case of a deletion in the Work, promptly cease construction activities with respect to such deleted Work. Added or revised Work shall be performed under the applicable conditions of the Contract Documents. Nothing in this paragraph shall obligate Contractor to undertake work that Contractor reasonably concludes cannot be performed in a manner consistent with Contractor's safety obligations under the Contract Documents or Laws and Regulations.

#### 11.03 *Unauthorized Changes in the Work*

- A. Contractor shall not be entitled to an increase in the Contract Price or an extension of the Contract Times with respect to any work performed that is not required by the Contract Documents, as amended, modified, or supplemented, except in the case of an emergency as provided in Paragraph 7.15 or in the case of uncovering Work as provided in Paragraph 14.05.

#### 11.04 *Change of Contract Price*

- A. The Contract Price may only be changed by a Change Order. Any Change Proposal for an adjustment in the Contract Price shall comply with the provisions of Paragraph 11.06. Any Claim for an adjustment of Contract Price shall comply with the provisions of Article 12.
- B. An adjustment in the Contract Price will be determined as follows:
  1. where the Work involved is covered by unit prices contained in the Contract Documents, then by application of such unit prices to the quantities of the items involved (subject to the provisions of Paragraph 13.03); or
  2. where the Work involved is not covered by unit prices contained in the Contract Documents, then by a mutually agreed lump sum (which may include an allowance for overhead and profit not necessarily in accordance with Paragraph 11.04.C.2); or
  3. where the Work involved is not covered by unit prices contained in the Contract Documents and the parties do not reach mutual agreement to a lump sum, then on

the basis of the Cost of the Work (determined as provided in Paragraph 13.01) plus a Contractor's fee for overhead and profit (determined as provided in Paragraph 11.04.C).

- C. *Contractor's Fee:* When applicable, the Contractor's fee for overhead and profit shall be determined as follows:

1. a mutually acceptable fixed fee; or
2. if a fixed fee is not agreed upon, then a fee based on the following percentages of the various portions of the Cost of the Work:
  - a. for costs incurred under Paragraphs 13.01.B.1 and 13.01.B.2, the Contractor's fee shall be 15 percent;
  - b. for costs incurred under Paragraph 13.01.B.3, the Contractor's fee shall be five percent;
  - c. where one or more tiers of subcontracts are on the basis of Cost of the Work plus a fee and no fixed fee is agreed upon, the intent of Paragraphs 11.04.C.2.a and 11.04.C.2.b is that the Contractor's fee shall be based on: (1) a fee of 15 percent of the costs incurred under Paragraphs 13.01.A.1 and 13.01.A.2 by the Subcontractor that actually performs the Work, at whatever tier, and (2) with respect to Contractor itself and to any Subcontractors of a tier higher than that of the Subcontractor that actually performs the Work, a fee of five percent of the amount (fee plus underlying costs incurred) attributable to the next lower tier Subcontractor; provided, however, that for any such subcontracted work the maximum total fee to be paid by Owner shall be no greater than 27 percent of the costs incurred by the Subcontractor that actually performs the work;
  - d. no fee shall be payable on the basis of costs itemized under Paragraphs 13.01.B.4, 13.01.B.5, and 13.01.C;
  - e. the amount of credit to be allowed by Contractor to Owner for any change which results in a net decrease in cost will be the amount of the actual net decrease in cost plus a deduction in Contractor's fee by an amount equal to five percent of such net decrease; and
  - f. when both additions and credits are involved in any one change, the adjustment in Contractor's fee shall be computed on the basis of the net change in accordance with Paragraphs 11.04.C.2.a through 11.04.C.2.e, inclusive.

#### 11.05 *Change of Contract Times*

- A. The Contract Times may only be changed by a Change Order. Any Change Proposal for an adjustment in the Contract Times shall comply with the provisions of Paragraph 11.06. Any Claim for an adjustment in the Contract Times shall comply with the provisions of Article 12.
- B. An adjustment of the Contract Times shall be subject to the limitations set forth in Paragraph 4.05, concerning delays in Contractor's progress.

#### 11.06 *Change Proposals*

- A. Contractor shall submit a Change Proposal to Engineer to request an adjustment in the Contract Times or Contract Price; appeal an initial decision by Engineer concerning the requirements of the Contract Documents or relating to the acceptability of the Work under the Contract Documents; contest a set-off against payment due; or seek other relief under

the Contract. The Change Proposal shall specify any proposed change in Contract Times or Contract Price, or both, or other proposed relief, and explain the reason for the proposed change, with citations to any governing or applicable provisions of the Contract Documents.

1. **Procedures:** Contractor shall submit each Change Proposal to Engineer promptly (but in no event later than 30 days) after the start of the event giving rise thereto, or after such initial decision. The Contractor shall submit supporting data, including the proposed change in Contract Price or Contract Time (if any), to the Engineer and Owner within 15 days after the submittal of the Change Proposal. The supporting data shall be accompanied by a written statement that the supporting data are accurate and complete, and that any requested time or price adjustment is the entire adjustment to which Contractor believes it is entitled as a result of said event. Engineer will advise Owner regarding the Change Proposal, and consider any comments or response from Owner regarding the Change Proposal.
  2. **Engineer's Action:** Engineer will review each Change Proposal and, within 30 days after receipt of the Contractor's supporting data, either deny the Change Proposal in whole, approve it in whole, or deny it in part and approve it in part. Such actions shall be in writing, with a copy provided to Owner and Contractor. If Engineer does not take action on the Change Proposal within 30 days, then either Owner or Contractor may at any time thereafter submit a letter to the other party indicating that as a result of Engineer's inaction the Change Proposal is deemed denied, thereby commencing the time for appeal of the denial under Article 12.
  3. **Binding Decision:** Engineer's decision will be final and binding upon Owner and Contractor, unless Owner or Contractor appeals the decision by filing a Claim under Article 12.
- B. **Resolution of Certain Change Proposals:** If the Change Proposal does not involve the design (as set forth in the Drawings, Specifications, or otherwise), the acceptability of the Work, or other engineering or technical matters, then Engineer will notify the parties that the Engineer is unable to resolve the Change Proposal. For purposes of further resolution of such a Change Proposal, such notice shall be deemed a denial, and Contractor may choose to seek resolution under the terms of Article 12.

#### 11.07 Execution of Change Orders

- A. Owner and Contractor shall execute appropriate Change Orders covering:
  1. changes in the Contract Price or Contract Times which are agreed to by the parties, including any undisputed sum or amount of time for Work actually performed in accordance with a Work Change Directive;
  2. changes in Contract Price resulting from an Owner set-off, unless Contractor has duly contested such set-off;
  3. changes in the Work which are: (a) ordered by Owner pursuant to Paragraph 11.02, (b) required because of Owner's acceptance of defective Work under Paragraph 14.04 or Owner's correction of defective Work under Paragraph 14.07, or (c) agreed to by the parties, subject to the need for Engineer's recommendation if the change in the Work involves the design (as set forth in the Drawings, Specifications, or otherwise), or other engineering or technical matters; and
  4. changes in the Contract Price or Contract Times, or other changes, which embody the substance of any final and binding results under Paragraph 11.06, or Article 12.

- B. If Owner or Contractor refuses to execute a Change Order that is required to be executed under the terms of this Paragraph 11.07, it shall be deemed to be of full force and effect, as if fully executed.

#### 11.08 Notification to Surety

- A. If the provisions of any bond require notice to be given to a surety of any change affecting the general scope of the Work or the provisions of the Contract Documents (including, but not limited to, Contract Price or Contract Times), the giving of any such notice will be Contractor's responsibility. The amount of each applicable bond will be adjusted to reflect the effect of any such change.

### ARTICLE 12 – CLAIMS

#### 12.01 Claims

- A. **Claims Process:** The following disputes between Owner and Contractor shall be submitted to the Claims process set forth in this Article:
  1. Appeals by Owner or Contractor of Engineer's decisions regarding Change Proposals;
  2. Owner demands for adjustments in the Contract Price or Contract Times, or other relief under the Contract Documents; and
  3. Disputes that Engineer has been unable to address because they do not involve the design (as set forth in the Drawings, Specifications, or otherwise), the acceptability of the Work, or other engineering or technical matters.
- B. **Submittal of Claim:** The party submitting a Claim shall deliver it directly to the other party to the Contract promptly (but in no event later than 30 days) after the start of the event giving rise thereto; in the case of appeals regarding Change Proposals within 30 days of the decision under appeal. The party submitting the Claim shall also furnish a copy to the Engineer, for its information only. The responsibility to substantiate a Claim shall rest with the party making the Claim. In the case of a Claim by Contractor seeking an increase in the Contract Times or Contract Price, or both, Contractor shall certify that the Claim is made in good faith, that the supporting data are accurate and complete, and that to the best of Contractor's knowledge and belief the amount of time or money requested accurately reflects the full amount to which Contractor is entitled.
- C. **Review and Resolution:** The party receiving a Claim shall review it thoroughly, giving full consideration to its merits. The two parties shall seek to resolve the Claim through the exchange of information and direct negotiations. The parties may extend the time for resolving the Claim by mutual agreement. All actions taken on a Claim shall be stated in writing and submitted to the other party, with a copy to Engineer.
- D. **Mediation:**
  1. At any time after initiation of a Claim, Owner and Contractor may mutually agree to mediation of the underlying dispute. The agreement to mediate shall stay the Claim submittal and response process.
  2. If Owner and Contractor agree to mediation, then after 60 days from such agreement, either Owner or Contractor may unilaterally terminate the mediation process, and the Claim submittal and decision process shall resume as of the date of the termination. If the mediation proceeds but is unsuccessful in resolving the dispute, the Claim

submittal and decision process shall resume as of the date of the conclusion of the mediation, as determined by the mediator.

3. Owner and Contractor shall each pay one-half of the mediator's fees and costs.
- E. *Partial Approval*: If the party receiving a Claim approves the Claim in part and denies it in part, such action shall be final and binding unless within 30 days of such action the other party invokes the procedure set forth in Article 17 for final resolution of disputes.
- F. *Denial of Claim*: If efforts to resolve a Claim are not successful, the party receiving the Claim may deny it by giving written notice of denial to the other party. If the receiving party does not take action on the Claim within 90 days, then either Owner or Contractor may at any time thereafter submit a letter to the other party indicating that as a result of the inaction, the Claim is deemed denied, thereby commencing the time for appeal of the denial. A denial of the Claim shall be final and binding unless within 30 days of the denial the other party invokes the procedure set forth in Article 17 for the final resolution of disputes.
- G. *Final and Binding Results*: If the parties reach a mutual agreement regarding a Claim, whether through approval of the Claim, direct negotiations, mediation, or otherwise; or if a Claim is approved in part and denied in part, or denied in full, and such actions become final and binding; then the results of the agreement or action on the Claim shall be incorporated in a Change Order to the extent they affect the Contract, including the Work, the Contract Times, or the Contract Price.

#### ARTICLE 13 – COST OF THE WORK; ALLOWANCES; UNIT PRICE WORK

##### 13.01 *Cost of the Work*

- A. *Purposes for Determination of Cost of the Work*: The term Cost of the Work means the sum of all costs necessary for the proper performance of the Work at issue, as further defined below. The provisions of this Paragraph 13.01 are used for two distinct purposes:
  1. To determine Cost of the Work when Cost of the Work is a component of the Contract Price, under cost-plus-fee, time-and-materials, or other cost-based terms; or
  2. To determine the value of a Change Order, Change Proposal, Claim, set-off, or other adjustment in Contract Price. When the value of any such adjustment is determined on the basis of Cost of the Work, Contractor is entitled only to those additional or incremental costs required because of the change in the Work or because of the event giving rise to the adjustment.
- B. *Costs Included*: Except as otherwise may be agreed to in writing by Owner, costs included in the Cost of the Work shall be in amounts no higher than those prevailing in the locality of the Project, shall not include any of the costs itemized in Paragraph 13.01.C, and shall include only the following items:
  1. Payroll costs for employees in the direct employ of Contractor in the performance of the Work under schedules of job classifications agreed upon by Owner and Contractor. Such employees shall include, without limitation, superintendents, foremen, and other personnel employed full time on the Work. Payroll costs for employees not employed full time on the Work shall be apportioned on the basis of their time spent on the Work. Payroll costs shall include, but not be limited to, salaries and wages plus the cost of fringe benefits, which shall include social security contributions, unemployment, excise, and payroll taxes, workers' compensation, health and retirement benefits, bonuses, sick leave, and vacation and holiday pay applicable

thereto. The expenses of performing Work outside of regular working hours, on Saturday, Sunday, or legal holidays, shall be included in the above to the extent authorized by Owner.

2. Cost of all materials and equipment furnished and incorporated in the Work, including costs of transportation and storage thereof, and Suppliers' field services required in connection therewith. All cash discounts shall accrue to Contractor unless Owner deposits funds with Contractor with which to make payments, in which case the cash discounts shall accrue to Owner. All trade discounts, rebates, and refunds and returns from sale of surplus materials and equipment shall accrue to Owner, and Contractor shall make provisions so that they may be obtained.
3. Payments made by Contractor to Subcontractors for Work performed by Subcontractors. If required by Owner, Contractor shall obtain competitive bids from subcontractors acceptable to Owner and Contractor and shall deliver such bids to Owner, who will then determine, with the advice of Engineer, which bids, if any, will be acceptable. If any subcontract provides that the Subcontractor is to be paid on the basis of Cost of the Work plus a fee, the Subcontractor's Cost of the Work and fee shall be determined in the same manner as Contractor's Cost of the Work and fee as provided in this Paragraph 13.01.
4. Costs of special consultants (including but not limited to engineers, architects, testing laboratories, surveyors, attorneys, and accountants) employed for services specifically related to the Work.
5. Supplemental costs including the following:
  - a. The proportion of necessary transportation, travel, and subsistence expenses of Contractor's employees incurred in discharge of duties connected with the Work.
  - b. Cost, including transportation and maintenance, of all materials, supplies, equipment, machinery, appliances, office, and temporary facilities at the Site, and hand tools not owned by the workers, which are consumed in the performance of the Work, and cost, less market value, of such items used but not consumed which remain the property of Contractor.
  - c. Rentals of all construction equipment and machinery, and the parts thereof, whether rented from Contractor or others in accordance with rental agreements approved by Owner with the advice of Engineer, and the costs of transportation, loading, unloading, assembly, dismantling, and removal thereof. All such costs shall be in accordance with the terms of said rental agreements. The rental of any such equipment, machinery, or parts shall cease when the use thereof is no longer necessary for the Work.
  - d. Sales, consumer, use, and other similar taxes related to the Work, and for which Contractor is liable, as imposed by Laws and Regulations.
  - e. Deposits lost for causes other than negligence of Contractor, any Subcontractor, or anyone directly or indirectly employed by any of them or for whose acts any of them may be liable, and royalty payments and fees for permits and licenses.
  - f. Losses and damages (and related expenses) caused by damage to the Work, not compensated by insurance or otherwise, sustained by Contractor in connection with the performance of the Work (except losses and damages within the deductible amounts of property insurance established in accordance with Paragraph 6.05), provided such losses and damages have resulted from causes

other than the negligence of Contractor, any Subcontractor, or anyone directly or indirectly employed by any of them or for whose acts any of them may be liable. Such losses shall include settlements made with the written consent and approval of Owner. No such losses, damages, and expenses shall be included in the Cost of the Work for the purpose of determining Contractor's fee.

- g. The cost of utilities, fuel, and sanitary facilities at the Site.
- h. Minor expenses such as communication service at the Site, express and courier services, and similar petty cash items in connection with the Work.
- i. The costs of premiums for all bonds and insurance that Contractor is required by the Contract Documents to purchase and maintain.

C. *Costs Excluded:* The term Cost of the Work shall not include any of the following items:

- 1. Payroll costs and other compensation of Contractor's officers, executives, principals (of partnerships and sole proprietorships), general managers, safety managers, engineers, architects, estimators, attorneys, auditors, accountants, purchasing and contracting agents, expeditors, timekeepers, clerks, and other personnel employed by Contractor, whether at the Site or in Contractor's principal or branch office for general administration of the Work and not specifically included in the agreed upon schedule of job classifications referred to in Paragraph 13.01.B.1 or specifically covered by Paragraph 13.01.B.4. The payroll costs and other compensation excluded here are to be considered administrative costs covered by the Contractor's fee.
- 2. Expenses of Contractor's principal and branch offices other than Contractor's office at the Site.
- 3. Any part of Contractor's capital expenses, including interest on Contractor's capital employed for the Work and charges against Contractor for delinquent payments.
- 4. Costs due to the negligence of Contractor, any Subcontractor, or anyone directly or indirectly employed by any of them or for whose acts any of them may be liable, including but not limited to, the correction of defective Work, disposal of materials or equipment wrongly supplied, and making good any damage to property.
- 5. Other overhead or general expense costs of any kind and the costs of any item not specifically and expressly included in Paragraph 13.01.B.

D. *Contractor's Fee:* When the Work as a whole is performed on the basis of cost-plus, Contractor's fee shall be determined as set forth in the Agreement. When the value of any Work covered by a Change Order, Change Proposal, Claim, set-off, or other adjustment in Contract Price is determined on the basis of Cost of the Work, Contractor's fee shall be determined as set forth in Paragraph 11.04.C.

E. *Documentation:* Whenever the Cost of the Work for any purpose is to be determined pursuant to this Article 13, Contractor will establish and maintain records thereof in accordance with generally accepted accounting practices and submit in a form acceptable to Engineer an itemized cost breakdown together with supporting data.

### 13.02 Allowances

- A. It is understood that Contractor has included in the Contract Price all allowances so named in the Contract Documents and shall cause the Work so covered to be performed for such sums and by such persons or entities as may be acceptable to Owner and Engineer.

B. *Cash Allowances:* Contractor agrees that:

- 1. the cash allowances include the cost to Contractor (less any applicable trade discounts) of materials and equipment required by the allowances to be delivered at the Site, and all applicable taxes; and
- 2. Contractor's costs for unloading and handling on the Site, labor, installation, overhead, profit, and other expenses contemplated for the cash allowances have been included in the Contract Price and not in the allowances, and no demand for additional payment on account of any of the foregoing will be valid.

C. *Contingency Allowance:* Contractor agrees that a contingency allowance, if any, is for the sole use of Owner to cover unanticipated costs.

D. Prior to final payment, an appropriate Change Order will be issued as recommended by Engineer to reflect actual amounts due Contractor on account of Work covered by allowances, and the Contract Price shall be correspondingly adjusted.

### 13.03 Unit Price Work

A. Where the Contract Documents provide that all or part of the Work is to be Unit Price Work, initially the Contract Price will be deemed to include for all Unit Price Work an amount equal to the sum of the unit price for each separately identified item of Unit Price Work times the estimated quantity of each item as indicated in the Agreement.

B. The estimated quantities of items of Unit Price Work are not guaranteed and are solely for the purpose of comparison of Bids and determining an initial Contract Price. Payments to Contractor for Unit Price Work will be based on actual quantities.

C. Each unit price will be deemed to include an amount considered by Contractor to be adequate to cover Contractor's overhead and profit for each separately identified item.

D. Engineer will determine the actual quantities and classifications of Unit Price Work performed by Contractor. Engineer will review with Contractor the Engineer's preliminary determinations on such matters before rendering a written decision thereon (by recommendation of an Application for Payment or otherwise). Engineer's written decision thereon will be final and binding (except as modified by Engineer to reflect changed factual conditions or more accurate data) upon Owner and Contractor, subject to the provisions of the following paragraph.

E. Within 30 days of Engineer's written decision under the preceding paragraph, Contractor may submit a Change Proposal, or Owner may file a Claim, seeking an adjustment in the Contract Price if:

- 1. the quantity of any item of Unit Price Work performed by Contractor differs materially and significantly from the estimated quantity of such item indicated in the Agreement;
- 2. there is no corresponding adjustment with respect to any other item of Work; and
- 3. Contractor believes that it is entitled to an increase in Contract Price as a result of having incurred additional expense or Owner believes that Owner is entitled to a decrease in Contract Price, and the parties are unable to agree as to the amount of any such increase or decrease.



ARTICLE 14 – TESTS AND INSPECTIONS; CORRECTION, REMOVAL OR ACCEPTANCE OF DEFECTIVE WORK

14.01 Access to Work

- A. Owner, Engineer, their consultants and other representatives and personnel of Owner, independent testing laboratories, and authorities having jurisdiction will have access to the Site and the Work at reasonable times for their observation, inspection, and testing. Contractor shall provide them proper and safe conditions for such access and advise them of Contractor's safety procedures and programs so that they may comply therewith as applicable.

14.02 Tests, Inspections, and Approvals

- A. Contractor shall give Engineer timely notice of readiness of the Work (or specific parts thereof) for all required inspections and tests, and shall cooperate with inspection and testing personnel to facilitate required inspections and tests.
- B. Owner shall retain and pay for the services of an independent inspector, testing laboratory, or other qualified individual or entity to perform all inspections and tests expressly required by the Contract Documents to be furnished and paid for by Owner, except that costs incurred in connection with tests or inspections of covered Work shall be governed by the provisions of Paragraph 14.05.
- C. If Laws or Regulations of any public body having jurisdiction require any Work (or part thereof) specifically to be inspected, tested, or approved by an employee or other representative of such public body, Contractor shall assume full responsibility for arranging and obtaining such inspections, tests, or approvals, pay all costs in connection therewith, and furnish Engineer the required certificates of inspection or approval.
- D. Contractor shall be responsible for arranging, obtaining, and paying for all inspections and tests required:
  - 1. by the Contract Documents, unless the Contract Documents expressly allocate responsibility for a specific inspection or test to Owner;
  - 2. to attain Owner's and Engineer's acceptance of materials or equipment to be incorporated in the Work;
  - 3. by manufacturers of equipment furnished under the Contract Documents;
  - 4. for testing, adjusting, and balancing of mechanical, electrical, and other equipment to be incorporated into the Work; and
  - 5. for acceptance of materials, mix designs, or equipment submitted for approval prior to Contractor's purchase thereof for incorporation in the Work.

Such inspections and tests shall be performed by independent inspectors, testing laboratories, or other qualified individuals or entities acceptable to Owner and Engineer.

- E. If the Contract Documents require the Work (or part thereof) to be approved by Owner, Engineer, or another designated individual or entity, then Contractor shall assume full responsibility for arranging and obtaining such approvals.
- F. If any Work (or the work of others) that is to be inspected, tested, or approved is covered by Contractor without written concurrence of Engineer, Contractor shall, if requested by Engineer, uncover such Work for observation. Such uncovering shall be at Contractor's expense unless Contractor had given Engineer timely notice of Contractor's intention to

cover the same and Engineer had not acted with reasonable promptness in response to such notice.

14.03 Defective Work

- A. *Contractor's Obligation:* It is Contractor's obligation to assure that the Work is not defective.
- B. *Engineer's Authority:* Engineer has the authority to determine whether Work is defective, and to reject defective Work.
- C. *Notice of Defects:* Prompt notice of all defective Work of which Owner or Engineer has actual knowledge will be given to Contractor.
- D. *Correction, or Removal and Replacement:* Promptly after receipt of written notice of defective Work, Contractor shall correct all such defective Work, whether or not fabricated, installed, or completed, or, if Engineer has rejected the defective Work, remove it from the Project and replace it with Work that is not defective.
- E. *Preservation of Warranties:* When correcting defective Work, Contractor shall take no action that would void or otherwise impair Owner's special warranty and guarantee, if any, on said Work.
- F. *Costs and Damages:* In addition to its correction, removal, and replacement obligations with respect to defective Work, Contractor shall pay all claims, costs, losses, and damages arising out of or relating to defective Work, including but not limited to the cost of the inspection, testing, correction, removal, replacement, or reconstruction of such defective Work, fines levied against Owner by governmental authorities because the Work is defective, and the costs of repair or replacement of work of others resulting from defective Work. Prior to final payment, if Owner and Contractor are unable to agree as to the measure of such claims, costs, losses, and damages resulting from defective Work, then Owner may impose a reasonable set-off against payments due under Article 15.

14.04 Acceptance of Defective Work

- A. If, instead of requiring correction or removal and replacement of defective Work, Owner prefers to accept it, Owner may do so (subject, if such acceptance occurs prior to final payment, to Engineer's confirmation that such acceptance is in general accord with the design intent and applicable engineering principles, and will not endanger public safety). Contractor shall pay all claims, costs, losses, and damages attributable to Owner's evaluation of and determination to accept such defective Work (such costs to be approved by Engineer as to reasonableness), and for the diminished value of the Work to the extent not otherwise paid by Contractor. If any such acceptance occurs prior to final payment, the necessary revisions in the Contract Documents with respect to the Work shall be incorporated in a Change Order. If the parties are unable to agree as to the decrease in the Contract Price, reflecting the diminished value of Work so accepted, then Owner may impose a reasonable set-off against payments due under Article 15. If the acceptance of defective Work occurs after final payment, Contractor shall pay an appropriate amount to Owner.

14.05 Uncovering Work

- A. Engineer has the authority to require additional inspection or testing of the Work, whether or not the Work is fabricated, installed, or completed.

- B. If any Work is covered contrary to the written request of Engineer, then Contractor shall, if requested by Engineer, uncover such Work for Engineer's observation, and then replace the covering, all at Contractor's expense.
- C. If Engineer considers it necessary or advisable that covered Work be observed by Engineer or inspected or tested by others, then Contractor, at Engineer's request, shall uncover, expose, or otherwise make available for observation, inspection, or testing as Engineer may require, that portion of the Work in question, and provide all necessary labor, material, and equipment.

1. If it is found that the uncovered Work is defective, Contractor shall be responsible for all claims, costs, losses, and damages arising out of or relating to such uncovering, exposure, observation, inspection, and testing, and of satisfactory replacement or reconstruction (including but not limited to all costs of repair or replacement of work of others); and pending Contractor's full discharge of this responsibility the Owner shall be entitled to impose a reasonable set-off against payments due under Article 15.
2. If the uncovered Work is not found to be defective, Contractor shall be allowed an increase in the Contract Price or an extension of the Contract Times, or both, directly attributable to such uncovering, exposure, observation, inspection, testing, replacement, and reconstruction. If the parties are unable to agree as to the amount or extent thereof, then Contractor may submit a Change Proposal within 30 days of the determination that the Work is not defective.

#### 14.06 Owner May Stop the Work

- A. If the Work is defective, or Contractor fails to supply sufficient skilled workers or suitable materials or equipment, or fails to perform the Work in such a way that the completed Work will conform to the Contract Documents, then Owner may order Contractor to stop the Work, or any portion thereof, until the cause for such order has been eliminated; however, this right of Owner to stop the Work shall not give rise to any duty on the part of Owner to exercise this right for the benefit of Contractor, any Subcontractor, any Supplier, any other individual or entity, or any surety for, or employee or agent of any of them.

#### 14.07 Owner May Correct Defective Work

- A. If Contractor fails within a reasonable time after written notice from Engineer to correct defective Work, or to remove and replace rejected Work as required by Engineer, or if Contractor fails to perform the Work in accordance with the Contract Documents, or if Contractor fails to comply with any other provision of the Contract Documents, then Owner may, after seven days written notice to Contractor, correct or remedy any such deficiency.
- B. In exercising the rights and remedies under this Paragraph 14.07, Owner shall proceed expeditiously. In connection with such corrective or remedial action, Owner may exclude Contractor from all or part of the Site, take possession of all or part of the Work and suspend Contractor's services related thereto, and incorporate in the Work all materials and equipment stored at the Site or for which Owner has paid Contractor but which are stored elsewhere. Contractor shall allow Owner, Owner's representatives, agents and employees, Owner's other contractors, and Engineer and Engineer's consultants access to the Site to enable Owner to exercise the rights and remedies under this paragraph.
- C. All claims, costs, losses, and damages incurred or sustained by Owner in exercising the rights and remedies under this Paragraph 14.07 will be charged against Contractor as set-offs against payments due under Article 15. Such claims, costs, losses and damages will

include but not be limited to all costs of repair, or replacement of work of others destroyed or damaged by correction, removal, or replacement of Contractor's defective Work.

- D. Contractor shall not be allowed an extension of the Contract Times because of any delay in the performance of the Work attributable to the exercise by Owner of Owner's rights and remedies under this Paragraph 14.07.

### ARTICLE 15 – PAYMENTS TO CONTRACTOR; SET-OFFS; COMPLETION; CORRECTION PERIOD

#### 15.01 Progress Payments

- A. *Basis for Progress Payments:* The Schedule of Values established as provided in Article 2 will serve as the basis for progress payments and will be incorporated into a form of Application for Payment acceptable to Engineer. Progress payments on account of Unit Price Work will be based on the number of units completed during the pay period, as determined under the provisions of Paragraph 13.03. Progress payments for cost-based Work will be based on Cost of the Work completed by Contractor during the pay period.

#### B. Applications for Payments:

1. At least 20 days before the date established in the Agreement for each progress payment (but not more often than once a month), Contractor shall submit to Engineer for review an Application for Payment filled out and signed by Contractor covering the Work completed as of the date of the Application and accompanied by such supporting documentation as is required by the Contract Documents. If payment is requested on the basis of materials and equipment not incorporated in the Work but delivered and suitably stored at the Site or at another location agreed to in writing, the Application for Payment shall also be accompanied by a bill of sale, invoice, or other documentation warranting that Owner has received the materials and equipment free and clear of all Liens, and evidence that the materials and equipment are covered by appropriate property insurance, a warehouse bond, or other arrangements to protect Owner's interest therein, all of which must be satisfactory to Owner.
2. Beginning with the second Application for Payment, each Application shall include an affidavit of Contractor stating that all previous progress payments received on account of the Work have been applied on account to discharge Contractor's legitimate obligations associated with prior Applications for Payment.
3. The amount of retainage with respect to progress payments will be as stipulated in the Agreement.

#### C. Review of Applications:

1. Engineer will, within 10 days after receipt of each Application for Payment, including each resubmittal, either indicate in writing a recommendation of payment and present the Application to Owner, or return the Application to Contractor indicating in writing Engineer's reasons for refusing to recommend payment. In the latter case, Contractor may make the necessary corrections and resubmit the Application.
2. Engineer's recommendation of any payment requested in an Application for Payment will constitute a representation by Engineer to Owner, based on Engineer's observations of the executed Work as an experienced and qualified design professional, and on Engineer's review of the Application for Payment and the accompanying data and schedules, that to the best of Engineer's knowledge, information and belief:

- a. the Work has progressed to the point indicated;
  - b. the quality of the Work is generally in accordance with the Contract Documents (subject to an evaluation of the Work as a functioning whole prior to or upon Substantial Completion, the results of any subsequent tests called for in the Contract Documents, a final determination of quantities and classifications for Unit Price Work under Paragraph 13.03, and any other qualifications stated in the recommendation); and
  - c. the conditions precedent to Contractor's being entitled to such payment appear to have been fulfilled in so far as it is Engineer's responsibility to observe the Work.
3. By recommending any such payment Engineer will not thereby be deemed to have represented that:
- a. inspections made to check the quality or the quantity of the Work as it has been performed have been exhaustive, extended to every aspect of the Work in progress, or involved detailed inspections of the Work beyond the responsibilities specifically assigned to Engineer in the Contract; or
  - b. there may not be other matters or issues between the parties that might entitle Contractor to be paid additionally by Owner or entitle Owner to withhold payment to Contractor.
4. Neither Engineer's review of Contractor's Work for the purposes of recommending payments nor Engineer's recommendation of any payment, including final payment, will impose responsibility on Engineer:
- a. to supervise, direct, or control the Work, or
  - b. for the means, methods, techniques, sequences, or procedures of construction, or the safety precautions and programs incident thereto, or
  - c. for Contractor's failure to comply with Laws and Regulations applicable to Contractor's performance of the Work, or
  - d. to make any examination to ascertain how or for what purposes Contractor has used the money paid on account of the Contract Price, or
  - e. to determine that title to any of the Work, materials, or equipment has passed to Owner free and clear of any Liens.
5. Engineer may refuse to recommend the whole or any part of any payment if, in Engineer's opinion, it would be incorrect to make the representations to Owner stated in Paragraph 15.01.C.2.
6. Engineer will recommend reductions in payment (set-offs) necessary in Engineer's opinion to protect Owner from loss because:
- a. the Work is defective, requiring correction or replacement;
  - b. the Contract Price has been reduced by Change Orders;
  - c. Owner has been required to correct defective Work in accordance with Paragraph 14.07, or has accepted defective Work pursuant to Paragraph 14.04;
  - d. Owner has been required to remove or remediate a Hazardous Environmental Condition for which Contractor is responsible; or

- e. Engineer has actual knowledge of the occurrence of any of the events that would constitute a default by Contractor and therefore justify termination for cause under the Contract Documents.

**D. Payment Becomes Due:**

- 1. Ten days after presentation of the Application for Payment to Owner with Engineer's recommendation, the amount recommended (subject to any Owner set-offs) will become due, and when due will be paid by Owner to Contractor.

**E. Reductions in Payment by Owner:**

- 1. In addition to any reductions in payment (set-offs) recommended by Engineer, Owner is entitled to impose a set-off against payment based on any of the following:
  - a. claims have been made against Owner on account of Contractor's conduct in the performance or furnishing of the Work, or Owner has incurred costs, losses, or damages on account of Contractor's conduct in the performance or furnishing of the Work, including but not limited to claims, costs, losses, or damages from workplace injuries, adjacent property damage, non-compliance with Laws and Regulations, and patent infringement;
  - b. Contractor has failed to take reasonable and customary measures to avoid damage, delay, disruption, and interference with other work at or adjacent to the Site;
  - c. Contractor has failed to provide and maintain required bonds or insurance;
  - d. Owner has been required to remove or remediate a Hazardous Environmental Condition for which Contractor is responsible;
  - e. Owner has incurred extra charges or engineering costs related to submittal reviews, evaluations of proposed substitutes, tests and inspections, or return visits to manufacturing or assembly facilities;
  - f. the Work is defective, requiring correction or replacement;
  - g. Owner has been required to correct defective Work in accordance with Paragraph 14.07, or has accepted defective Work pursuant to Paragraph 14.04;
  - h. the Contract Price has been reduced by Change Orders;
  - i. an event that would constitute a default by Contractor and therefore justify a termination for cause has occurred;
  - j. liquidated damages have accrued as a result of Contractor's failure to achieve Milestones, Substantial Completion, or final completion of the Work;
  - k. Liens have been filed in connection with the Work, except where Contractor has delivered a specific bond satisfactory to Owner to secure the satisfaction and discharge of such Liens;
  - l. there are other items entitling Owner to a set off against the amount recommended.
- 2. If Owner imposes any set-off against payment, whether based on its own knowledge or on the written recommendations of Engineer, Owner will give Contractor immediate written notice (with a copy to Engineer) stating the reasons for such action and the specific amount of the reduction, and promptly pay Contractor any amount

remaining after deduction of the amount so withheld. Owner shall promptly pay Contractor the amount so withheld, or any adjustment thereto agreed to by Owner and Contractor, if Contractor remedies the reasons for such action. The reduction imposed shall be binding on Contractor unless it duly submits a Change Proposal contesting the reduction.

3. Upon a subsequent determination that Owner's refusal of payment was not justified, the amount wrongfully withheld shall be treated as an amount due as determined by Paragraph 15.01.C.1 and subject to interest as provided in the Agreement.

#### 15.02 Contractor's Warranty of Title

- A. Contractor warrants and guarantees that title to all Work, materials, and equipment furnished under the Contract will pass to Owner free and clear of (1) all Liens and other title defects, and (2) all patent, licensing, copyright, or royalty obligations, no later than seven days after the time of payment by Owner.

#### 15.03 Substantial Completion

- A. When Contractor considers the entire Work ready for its intended use Contractor shall notify Owner and Engineer in writing that the entire Work is substantially complete and request that Engineer issue a certificate of Substantial Completion. Contractor shall at the same time submit to Owner and Engineer an initial draft of punch list items to be completed or corrected before final payment.
- B. Promptly after Contractor's notification, Owner, Contractor, and Engineer shall make an inspection of the Work to determine the status of completion. If Engineer does not consider the Work substantially complete, Engineer will notify Contractor in writing giving the reasons therefor.
- C. If Engineer considers the Work substantially complete, Engineer will deliver to Owner a preliminary certificate of Substantial Completion which shall fix the date of Substantial Completion. Engineer shall attach to the certificate a punch list of items to be completed or corrected before final payment. Owner shall have seven days after receipt of the preliminary certificate during which to make written objection to Engineer as to any provisions of the certificate or attached punch list. If, after considering the objections to the provisions of the preliminary certificate, Engineer concludes that the Work is not substantially complete, Engineer will, within 14 days after submission of the preliminary certificate to Owner, notify Contractor in writing that the Work is not substantially complete, stating the reasons therefor. If Owner does not object to the provisions of the certificate, or if despite consideration of Owner's objections Engineer concludes that the Work is substantially complete, then Engineer will, within said 14 days, execute and deliver to Owner and Contractor a final certificate of Substantial Completion (with a revised punch list of items to be completed or corrected) reflecting such changes from the preliminary certificate as Engineer believes justified after consideration of any objections from Owner.
- D. At the time of receipt of the preliminary certificate of Substantial Completion, Owner and Contractor will confer regarding Owner's use or occupancy of the Work following Substantial Completion, review the builder's risk insurance policy with respect to the end of the builder's risk coverage, and confirm the transition to coverage of the Work under a permanent property insurance policy held by Owner. Unless Owner and Contractor agree otherwise in writing, Owner shall bear responsibility for security, operation, protection of the Work, property insurance, maintenance, heat, and utilities upon Owner's use or occupancy of the Work.

- E. After Substantial Completion the Contractor shall promptly begin work on the punch list of items to be completed or corrected prior to final payment. In appropriate cases Contractor may submit monthly Applications for Payment for completed punch list items, following the progress payment procedures set forth above.
- F. Owner shall have the right to exclude Contractor from the Site after the date of Substantial Completion subject to allowing Contractor reasonable access to remove its property and complete or correct items on the punch list.

#### 15.04 Partial Use or Occupancy

- A. Prior to Substantial Completion of all the Work, Owner may use or occupy any substantially completed part of the Work which has specifically been identified in the Contract Documents, or which Owner, Engineer, and Contractor agree constitutes a separately functioning and usable part of the Work that can be used by Owner for its intended purpose without significant interference with Contractor's performance of the remainder of the Work, subject to the following conditions:
  1. At any time Owner may request in writing that Contractor permit Owner to use or occupy any such part of the Work that Owner believes to be substantially complete. If and when Contractor agrees that such part of the Work is substantially complete, Contractor, Owner, and Engineer will follow the procedures of Paragraph 15.03.A through E for that part of the Work.
  2. At any time Contractor may notify Owner and Engineer in writing that Contractor considers any such part of the Work substantially complete and request Engineer to issue a certificate of Substantial Completion for that part of the Work.
  3. Within a reasonable time after either such request, Owner, Contractor, and Engineer shall make an inspection of that part of the Work to determine its status of completion. If Engineer does not consider that part of the Work to be substantially complete, Engineer will notify Owner and Contractor in writing giving the reasons therefor. If Engineer considers that part of the Work to be substantially complete, the provisions of Paragraph 15.03 will apply with respect to certification of Substantial Completion of that part of the Work and the division of responsibility in respect thereof and access thereto.
  4. No use or occupancy or separate operation of part of the Work may occur prior to compliance with the requirements of Paragraph 6.05 regarding builder's risk or other property insurance.

#### 15.05 Final Inspection

- A. Upon written notice from Contractor that the entire Work or an agreed portion thereof is complete, Engineer will promptly make a final inspection with Owner and Contractor and will notify Contractor in writing of all particulars in which this inspection reveals that the Work, or agreed portion thereof, is incomplete or defective. Contractor shall immediately take such measures as are necessary to complete such Work or remedy such deficiencies.

#### 15.06 Final Payment

- A. Application for Payment:
  1. After Contractor has, in the opinion of Engineer, satisfactorily completed all corrections identified during the final inspection and has delivered, in accordance with the Contract Documents, all maintenance and operating instructions, schedules, guarantees, bonds, certificates or other evidence of insurance, certificates of

inspection, annotated record documents (as provided in Paragraph 7.11), and other documents, Contractor may make application for final payment.

2. The final Application for Payment shall be accompanied (except as previously delivered) by:
  - a. all documentation called for in the Contract Documents;
  - b. consent of the surety, if any, to final payment;
  - c. satisfactory evidence that all title issues have been resolved such that title to all Work, materials, and equipment has passed to Owner free and clear of any Liens or other title defects, or will so pass upon final payment.
  - d. a list of all disputes that Contractor believes are unsettled; and
  - e. complete and legally effective releases or waivers (satisfactory to Owner) of all Lien rights arising out of the Work, and of Liens filed in connection with the Work.
3. In lieu of the releases or waivers of Liens specified in Paragraph 15.06.A.2 and as approved by Owner, Contractor may furnish receipts or releases in full and an affidavit of Contractor that: (a) the releases and receipts include all labor, services, material, and equipment for which a Lien could be filed; and (b) all payrolls, material and equipment bills, and other indebtedness connected with the Work for which Owner might in any way be responsible, or which might in any way result in liens or other burdens on Owner's property, have been paid or otherwise satisfied. If any Subcontractor or Supplier fails to furnish such a release or receipt in full, Contractor may furnish a bond or other collateral satisfactory to Owner to indemnify Owner against any Lien, or Owner at its option may issue joint checks payable to Contractor and specified Subcontractors and Suppliers.

**B. Engineer's Review of Application and Acceptance:**

1. If, on the basis of Engineer's observation of the Work during construction and final inspection, and Engineer's review of the final Application for Payment and accompanying documentation as required by the Contract Documents, Engineer is satisfied that the Work has been completed and Contractor's other obligations under the Contract have been fulfilled, Engineer will, within ten days after receipt of the final Application for Payment, indicate in writing Engineer's recommendation of final payment and present the Application for Payment to Owner for payment. Such recommendation shall account for any set-offs against payment that are necessary in Engineer's opinion to protect Owner from loss for the reasons stated above with respect to progress payments. At the same time Engineer will also give written notice to Owner and Contractor that the Work is acceptable, subject to the provisions of Paragraph 15.07. Otherwise, Engineer will return the Application for Payment to Contractor, indicating in writing the reasons for refusing to recommend final payment, in which case Contractor shall make the necessary corrections and resubmit the Application for Payment.
- C. **Completion of Work:** The Work is complete (subject to surviving obligations) when it is ready for final payment as established by the Engineer's written recommendation of final payment.
- D. **Payment Becomes Due:** Thirty days after the presentation to Owner of the final Application for Payment and accompanying documentation, the amount recommended by Engineer (less any further sum Owner is entitled to set off against Engineer's recommendation,

including but not limited to set-offs for liquidated damages and set-offs allowed under the provisions above with respect to progress payments) will become due and shall be paid by Owner to Contractor.

**15.07 Waiver of Claims**

- A. The making of final payment will not constitute a waiver by Owner of claims or rights against Contractor. Owner expressly reserves claims and rights arising from unsettled Liens, from defective Work appearing after final inspection pursuant to Paragraph 15.05, from Contractor's failure to comply with the Contract Documents or the terms of any special guarantees specified therein, from outstanding Claims by Owner, or from Contractor's continuing obligations under the Contract Documents.
- B. The acceptance of final payment by Contractor will constitute a waiver by Contractor of all claims and rights against Owner other than those pending matters that have been duly submitted or appealed under the provisions of Article 17.

**15.08 Correction Period**

- A. If within one year after the date of Substantial Completion (or such longer period of time as may be prescribed by the terms of any applicable special guarantee required by the Contract Documents, or by any specific provision of the Contract Documents), any Work is found to be defective, or if the repair of any damages to the Site, adjacent areas that Contractor has arranged to use through construction easements or otherwise, and other adjacent areas used by Contractor as permitted by Laws and Regulations, is found to be defective, then Contractor shall promptly, without cost to Owner and in accordance with Owner's written instructions:
  1. correct the defective repairs to the Site or such other adjacent areas;
  2. correct such defective Work;
  3. if the defective Work has been rejected by Owner, remove it from the Project and replace it with Work that is not defective, and
  4. satisfactorily correct or repair or remove and replace any damage to other Work, to the work of others, or to other land or areas resulting therefrom.
- B. If Contractor does not promptly comply with the terms of Owner's written instructions, or in an emergency where delay would cause serious risk of loss or damage, Owner may have the defective Work corrected or repaired or may have the rejected Work removed and replaced. Contractor shall pay all claims, costs, losses, and damages (including but not limited to all fees and charges of engineers, architects, attorneys, and other professionals and all court or arbitration or other dispute resolution costs) arising out of or relating to such correction or repair or such removal and replacement (including but not limited to all costs of repair or replacement of work of others).
- C. In special circumstances where a particular item of equipment is placed in continuous service before Substantial Completion of all the Work, the correction period for that item may start to run from an earlier date if so provided in the Specifications.
- D. Where defective Work (and damage to other Work resulting therefrom) has been corrected or removed and replaced under this paragraph, the correction period hereunder with respect to such Work will be extended for an additional period of one year after such correction or removal and replacement has been satisfactorily completed.

- E. Contractor's obligations under this paragraph are in addition to all other obligations and warranties. The provisions of this paragraph shall not be construed as a substitute for, or a waiver of, the provisions of any applicable statute of limitation or repose.

#### ARTICLE 16 – SUSPENSION OF WORK AND TERMINATION

##### 16.01 *Owner May Suspend Work*

- A. At any time and without cause, Owner may suspend the Work or any portion thereof for a period of not more than 90 consecutive days by written notice to Contractor and Engineer. Such notice will fix the date on which Work will be resumed. Contractor shall resume the Work on the date so fixed. Contractor shall be entitled to an adjustment in the Contract Price or an extension of the Contract Times, or both, directly attributable to any such suspension. Any Change Proposal seeking such adjustments shall be submitted no later than 30 days after the date fixed for resumption of Work.

##### 16.02 *Owner May Terminate for Cause*

- A. The occurrence of any one or more of the following events will constitute a default by Contractor and justify termination for cause:
1. Contractor's persistent failure to perform the Work in accordance with the Contract Documents (including, but not limited to, failure to supply sufficient skilled workers or suitable materials or equipment or failure to adhere to the Progress Schedule);
  2. Failure of Contractor to perform or otherwise to comply with a material term of the Contract Documents;
  3. Contractor's disregard of Laws or Regulations of any public body having jurisdiction; or
  4. Contractor's repeated disregard of the authority of Owner or Engineer.
- B. If one or more of the events identified in Paragraph 16.02.A occurs, then after giving Contractor (and any surety) ten days written notice that Owner is considering a declaration that Contractor is in default and termination of the contract, Owner may proceed to:
1. declare Contractor to be in default, and give Contractor (and any surety) notice that the Contract is terminated; and
  2. enforce the rights available to Owner under any applicable performance bond.
- C. Subject to the terms and operation of any applicable performance bond, if Owner has terminated the Contract for cause, Owner may exclude Contractor from the Site, take possession of the Work, incorporate in the Work all materials and equipment stored at the Site or for which Owner has paid Contractor but which are stored elsewhere, and complete the Work as Owner may deem expedient.
- D. Owner may not proceed with termination of the Contract under Paragraph 16.02.B if Contractor within seven days of receipt of notice of intent to terminate begins to correct its failure to perform and proceeds diligently to cure such failure.
- E. If Owner proceeds as provided in Paragraph 16.02.B, Contractor shall not be entitled to receive any further payment until the Work is completed. If the unpaid balance of the Contract Price exceeds the cost to complete the Work, including all related claims, costs, losses, and damages (including but not limited to all fees and charges of engineers, architects, attorneys, and other professionals) sustained by Owner, such excess will be paid to Contractor. If the cost to complete the Work including such related claims, costs, losses,

and damages exceeds such unpaid balance, Contractor shall pay the difference to Owner. Such claims, costs, losses, and damages incurred by Owner will be reviewed by Engineer as to their reasonableness and, when so approved by Engineer, incorporated in a Change Order. When exercising any rights or remedies under this paragraph, Owner shall not be required to obtain the lowest price for the Work performed.

- F. Where Contractor's services have been so terminated by Owner, the termination will not affect any rights or remedies of Owner against Contractor then existing or which may thereafter accrue, or any rights or remedies of Owner against Contractor or any surety under any payment bond or performance bond. Any retention or payment of money due Contractor by Owner will not release Contractor from liability.
- G. If and to the extent that Contractor has provided a performance bond under the provisions of Paragraph 6.01.A, the provisions of that bond shall govern over any inconsistent provisions of Paragraphs 16.02.B and 16.02.D.

##### 16.03 *Owner May Terminate For Convenience*

- A. Upon seven days written notice to Contractor and Engineer, Owner may, without cause and without prejudice to any other right or remedy of Owner, terminate the Contract. In such case, Contractor shall be paid for (without duplication of any items):
1. completed and acceptable Work executed in accordance with the Contract Documents prior to the effective date of termination, including fair and reasonable sums for overhead and profit on such Work;
  2. expenses sustained prior to the effective date of termination in performing services and furnishing labor, materials, or equipment as required by the Contract Documents in connection with uncompleted Work, plus fair and reasonable sums for overhead and profit on such expenses; and
  3. other reasonable expenses directly attributable to termination, including costs incurred to prepare a termination for convenience cost proposal.
- B. Contractor shall not be paid on account of loss of anticipated overhead, profits, or revenue, or other economic loss arising out of or resulting from such termination.

##### 16.04 *Contractor May Stop Work or Terminate*

- A. If, through no act or fault of Contractor, (1) the Work is suspended for more than 90 consecutive days by Owner or under an order of court or other public authority, or (2) Engineer fails to act on any Application for Payment within 30 days after it is submitted, or (3) Owner fails for 30 days to pay Contractor any sum finally determined to be due, then Contractor may, upon seven days written notice to Owner and Engineer, and provided Owner or Engineer do not remedy such suspension or failure within that time, terminate the contract and recover from Owner payment on the same terms as provided in Paragraph 16.03.
- B. In lieu of terminating the Contract and without prejudice to any other right or remedy, if Engineer has failed to act on an Application for Payment within 30 days after it is submitted, or Owner has failed for 30 days to pay Contractor any sum finally determined to be due, Contractor may, seven days after written notice to Owner and Engineer, stop the Work until payment is made of all such amounts due Contractor, including interest thereon. The provisions of this paragraph are not intended to preclude Contractor from submitting a Change Proposal for an adjustment in Contract Price or Contract Times or otherwise for

expenses or damage directly attributable to Contractor's stopping the Work as permitted by this paragraph.

## ARTICLE 17 – FINAL RESOLUTION OF DISPUTES

### 17.01 *Methods and Procedures*

- A. *Disputes Subject to Final Resolution:* The following disputed matters are subject to final resolution under the provisions of this Article:
1. A timely appeal of an approval in part and denial in part of a Claim, or of a denial in full; and
  2. Disputes between Owner and Contractor concerning the Work or obligations under the Contract Documents, and arising after final payment has been made.
- B. *Final Resolution of Disputes:* For any dispute subject to resolution under this Article, Owner or Contractor may:
1. elect in writing to invoke the dispute resolution process provided for in the Supplementary Conditions; or
  2. agree with the other party to submit the dispute to another dispute resolution process; or
  3. if no dispute resolution process is provided for in the Supplementary Conditions or mutually agreed to, give written notice to the other party of the intent to submit the dispute to a court of competent jurisdiction.

## ARTICLE 18 – MISCELLANEOUS

### 18.01 *Giving Notice*

- A. Whenever any provision of the Contract Documents requires the giving of written notice, it will be deemed to have been validly given if:
1. delivered in person, by a commercial courier service or otherwise, to the individual or to a member of the firm or to an officer of the corporation for which it is intended; or
  2. delivered at or sent by registered or certified mail, postage prepaid, to the last business address known to the sender of the notice.

### 18.02 *Computation of Times*

- A. When any period of time is referred to in the Contract by days, it will be computed to exclude the first and include the last day of such period. If the last day of any such period falls on a Saturday or Sunday or on a day made a legal holiday by the law of the applicable jurisdiction, such day will be omitted from the computation.

### 18.03 *Cumulative Remedies*

- A. The duties and obligations imposed by these General Conditions and the rights and remedies available hereunder to the parties hereto are in addition to, and are not to be construed in any way as a limitation of, any rights and remedies available to any or all of them which are otherwise imposed or available by Laws or Regulations, by special warranty or guarantee, or by other provisions of the Contract. The provisions of this paragraph will be as effective as if repeated specifically in the Contract Documents in connection with each particular duty, obligation, right, and remedy to which they apply.

### 18.04 *Limitation of Damages*

- A. With respect to any and all Change Proposals, Claims, disputes subject to final resolution, and other matters at issue, neither Owner nor Engineer, nor any of their officers, directors, members, partners, employees, agents, consultants, or subcontractors, shall be liable to Contractor for any claims, costs, losses, or damages sustained by Contractor on or in connection with any other project or anticipated project.

### 18.05 *No Waiver*

- A. A party's non-enforcement of any provision shall not constitute a waiver of that provision, nor shall it affect the enforceability of that provision or of the remainder of this Contract.

### 18.06 *Survival of Obligations*

- A. All representations, indemnifications, warranties, and guarantees made in, required by, or given in accordance with the Contract, as well as all continuing obligations indicated in the Contract, will survive final payment, completion, and acceptance of the Work or termination or completion of the Contract or termination of the services of Contractor.

### 18.07 *Controlling Law*

- A. This Contract is to be governed by the law of the state in which the Project is located.

### 18.08 *Headings*

- A. Article and paragraph headings are inserted for convenience only and do not constitute parts of these General Conditions.

**SUPPLEMENTARY GENERAL CONDITIONS**



**SUPPLEMENTARY GENERAL CONDITIONS**

## SUPPLEMENTARY GENERAL CONDITIONS

The following Supplementary Conditions modify, change, delete from or add to the Standard General Conditions of the Construction Contract EJCDC (C-700, 2013 Edition). Where any Article of the General Conditions is modified, or any Paragraph, Subparagraph or Clause thereof is modified or deleted by these supplements, the unaltered provisions of that Article, Paragraph, Subparagraph or Clause shall remain in effect.

### 1. Article 6 - BONDS AND INSURANCE

A. Add the following to paragraph 6.01.C: All bonds shall be written through companies rated with A.M. Best rating of A or better.

B. The limits of liability for insurance required by paragraph 6.03 of the General Conditions shall provide coverage for not less than the following amounts or greater where required by Laws and Regulations:

1. Workers' Compensation, and related coverages under paragraphs 6.03.A of the General Conditions:

a.	State:	Statutory
b.	Applicable Federal (e.g., Longshoremen's)	Statutory
c.	Employer's Liability	\$500,000

2. Contractor's General Liability under paragraphs 6.03.B of the General Conditions which shall include completed operations and product liability coverages and eliminate the exclusion with respect to property under the care, custody, and control of the Contractor:

a.	General Aggregate	\$2,000,000
b.	Products - Completed Operations Aggregate	\$1,000,000
c.	Personal and Advertising Injury	\$1,000,000
d.	Each Occurrence (Bodily Injury and Property Damage)	\$1,000,000
e.	Property Damage liability insurance will provide Explosion, Collapse, and Underground coverages where applicable.	\$1,000,000
f.	Excess or Umbrella Liability	
	1) General Aggregate	\$1,000,000
	2) Each Occurrence	\$1,000,000
g.	Contractor shall name the Owner and Engineer as an additional insured.	

- A. For all overtime in excess of eight hours in any one day or 40 hours in any one week when the work week is five consecutive days, Monday through Friday; or
- B. For all overtime in excess of 10 hours in any one day or 40 hours in any one week when the work week is four consecutive days, Monday through Friday; and
- C. For all work performed on Saturday and on any legal holiday specified in ORS 279C.540.

An employer must give notice in writing to employees who work on a public contract, either at the time of hire or before commencement of work on the contract, or by posting a notice in a location frequented by employees, of the number of hours per day and days per week that the employees may be required to work.

- 19.08 In accordance with 279C.530 the contractor shall promptly, as due, make payment to any person, copartnership, association or corporation furnishing medical, surgical and hospital care services or other needed care and attention, incident to sickness or injury, to the employees of the contractor, of all sums that the contractor agrees to pay for the services and all moneys and sums that the contractor collected or deducted from the wages of employees under any law, contract or agreement for the purpose of providing or paying for the services. All subject employers working under the contract must be either employers that will comply with ORS 656.017 or employers that are exempt under ORS 656.126. Contractor shall ensure that each of its subcontractors complies with these requirements.
- 19.09 In accordance with ORS 279C.545, any worker employed by the contractor shall be foreclosed from the right to collect for any overtime provided in ORS 279C.540 unless a claim for payment is filed with the Contractor within 90 days from the completion of the contract, providing the Contractor has (1) caused a circular clearly printed in boldfaced 12-point type and containing a copy of this section to be posted in a prominent place alongside the door of the timekeeper's office or in a similar place that is readily available and freely visible to workers employed on the work, and (2) maintained the circular continuously posted from the inception to the completion of the contract on which workers are or have been employed.
- 19.10 The Contractor shall comply with the requirements of ORS 279C.570 as they apply including prompt payment policy, progress payments and rate of interest.
- 19.11 The Contractor shall comply with the provisions of ORS 279C.580 as they apply with regard to Contractor's relation with subcontractors, including that the Contractor is required to include in each subcontract entered into with a first-tier subcontractor, including a material supplier, for the purpose of performing a construction contract:
- A. A payment clause obligating the Contractor to pay the first-tier subcontractor for satisfactory performance under its subcontract within

10 days out of amounts the OWNER pays to the Contractor under the public improvement contract;

- B. A clause that requires the Contractor to provide a first-tier subcontractor with a standard form for application for payment.
  - C. A clause that requires the Contractor to use the standard form and administrative procedures for payment for the entire term of the subcontract.
  - E. An interest penalty clause conforming with ORS 279C.580(3)(b).
- 19.12 The Contractor shall comply with the provisions of ORS 279C.605 as they apply with regard to notice of claims.
- 19.13 This public works contract is subject to the requirements of the Oregon Prevailing Wage Rates. In accordance with 279C.830 Contractor shall comply with the existing state prevailing rate of wage that must be paid to workers in each trade or occupation required for the public works employed in the performance of the contract either by the Contractor or subcontractor or other person doing or contracting to do the whole or any part of the work contemplated by the contract. Workers shall be paid not less than the specified minimum hourly rate of wage.
- 19.14 The OWNER will pay the required fee to the Commissioner of the Bureau of Labor and Industries as provided in ORS 279C.825 (1), under the administrative rule of the commissioner.
- 19.15 The Contractor and every subcontractor must have a public works bond filed with the Construction Contractors Board before starting work on the project, unless exempt under ORS 279C.836 (7) or (8). Contractor shall also include in every subcontract a provision requiring the subcontractor to have a public works bond filed with the Construction Contractors Board before starting work on the project, unless exempt under ORS 279C.836 (7) or (8).
- 19.16 By Submission of a bid the Contractor certifies compliance with the Oregon tax laws in accordance with ORS 305.385.

5. Add the following:

Article 20. FEDERAL, STATE AND LOCAL STATUTES

- 20.01 CONTRACTOR is responsible for compliance with State and Federal safety and health acts, ORS 654.001 et. seq., and 29 USC 651 et. seq., and the regulations promulgated thereunder.
- 20.02 The CONTRACTOR shall comply with all federal, state and local laws, regulations, executive orders and ordinances applicable to the work under this agreement. Without limiting the generality of the foregoing, CONTRACTOR expressly agrees to comply with (i) Title VI of the Civil Rights Act of 1964; (ii) Section V of the Rehabilitation

Act of 1973; (iii) the Americans with Disabilities Act of 1990 and ORS 659A.142; (iv) all regulations and administrative rules established pursuant to the foregoing laws; (v) all other applicable requirements of federal and state civil rights and rehabilitation statutes, rules and regulations; and (vi) the environmental laws and regulations enacted by appropriate public agencies.

An employer must give notice in writing to employees who work on a public contract, either at the time of hire or before commencement of work on the contract, or by posting a notice in a location frequented by employees, of the number of hours per day and days per week that the employees may be required to work.

PREVAILING WAGE RATE FORMS

PREVAILING WAGE RATE FORMS

## **PREVAILING WAGE RATES FOR PUBLIC WORKS CONSTRUCTION**

This project is subject to the State of OREGON BOLI Prevailing Wage Rates, as of the date of the publication soliciting bids, which are incorporated by reference.

The current Prevailing Wage Rate Book is available online and can be viewed and printed in its entirety at: <http://www.oregon.gov>



*This Page Intentionally Left Blank*



**TECHNICAL SPECIFICATIONS**

**DIVISION 1 - GENERAL REQUIREMENTS**

**DIVISION 1 - GENERAL REQUIREMENTS**

**SECTION 01000  
GENERAL REQUIREMENTS**

**PART 1 - GENERAL**

1.01 SUMMARY OF WORK

- A. The CONTRACTOR shall furnish all labor, materials and equipment necessary to complete the Work in all respects as shown on the plans and/or as specified herein and under the terms of the Contract.
- B. The scope of work in this Contract is as described in the Notice to Contractors, Contract for Construction and the Bid Proposal.

1.02 GENERAL CONSTRUCTION

- A. The intent of the Contract Documents is to ensure the systematic implementation of construction with a minimum of public inconvenience. The CONTRACTOR shall coordinate his work to minimize any inconvenience to the public and to private property owners.
- B. The CONTRACTOR shall have on the job, at all times, a qualified superintendent as his agent, who is capable of reading and understanding the Contract Documents and is thoroughly experienced in the type of work being performed. The Superintendent shall be responsible for the progress of construction and the CONTRACTOR'S operations.
- C. The CONTRACTOR shall be responsible for cooperation with other utilities and any other contractors which might be employed by the OWNER on the project.
- D. The CONTRACTOR is responsible for maintenance of all streets, roads and construction sites within which Work is done until final acceptance of the Work by the OWNER. The CONTRACTOR shall pay all costs of modifying existing utility systems to meet specific construction needs, if required.
- E. The CONTRACTOR shall perform the Work in accordance with the plans, specifications and Contract terms except as modified in writing by the ENGINEER. He shall perform all work determined by the ENGINEER as necessary to properly prosecute and complete the project.
- F. The CONTRACTOR is responsible for controlling stormwater, mud, debris and the disposition of construction related materials. These substances shall be positively prevented from entering the storm drain system. Clean up resulting from the improper handling of these substances will be the CONTRACTOR'S responsibility.

G. Conflicts in the contract documents shall be resolved based on the following priority:

1. Technical Specifications
2. Design Drawings
3. Supplementary General Conditions
4. General Conditions

#### 1.03 CONSTRUCTION LAYOUT

- A. The Work shall be located from staking provided by the OWNER. One set of stakes will be provided for sanitary sewers, and one set for curb stakes in a location selected by the Contractor. The CONTRACTOR shall protect and pay all costs to replace stakes lost during construction.
- B. The CONTRACTOR shall be responsible for replacement of all permanent reference points, stakes, monuments and property corners if they are disturbed by the construction. Recorded boundary markers shall be replaced by a Registered Professional Land Surveyor. No permanent, recorded boundary markers shall be removed or disturbed without authorization of the ENGINEER.

#### 1.04 WARRANTY

The CONTRACTOR shall make all necessary repairs and replacements to remedy in a manner satisfactory to the ENGINEER and at no cost to the OWNER, any and all defects, breaks, or failures of the work occurring within ONE (1) YEAR FOLLOWING THE DATE OF FINAL ACCEPTANCE of the work due to: faulty or inadequate materials or workmanship, and for damage or disturbances to other improvements under, within or adjacent to the work whether or not caused by settling, washing or slipping when such damage or disturbance is caused, in whole or in part, from activities of the CONTRACTOR in performing the duties and obligations under this contract. When such defects or damage occur within the time period described hereinbefore, in any part of the surface or subsurface work done under the contract, or in any adjacent surface or subsurface improvement not included in the work under the contract, the CONTRACTOR shall repair the same and the one year maintenance period required shall, with relation to such required repair, be extended one year from the date of completion of such repair.

#### 1.05 CONTRACTOR RESPONSIBILITY

- A. The CONTRACTOR shall be fully informed on all Federal and State laws and all local laws, ordinances and regulations of bodies having jurisdiction or authority or which in any way might affect the conduct of the Work.
- B. The CONTRACTOR shall indemnify and protect the OWNER and ENGINEER against any claim or liability arising from a violation of any law, ordinance or regulation by himself, any subcontractor or employee of the CONTRACTOR or subcontractor.

- C. The CONTRACTOR shall obtain and pay for all licenses and permits and shall be responsible for all fees, taxes or payments required for the lawful and due performance of the Work, except as defined herein. The CONTRACTOR shall obtain a City of Canby Business License.
- D. The CONTRACTOR shall be solely responsible for any trespass on adjacent properties or injury thereto, resulting from his operations. All private property damaged by his operations shall be fully restored to preconstruction conditions.
- E. Public safety and convenience shall be paramount in the CONTRACTOR'S operations and shall be provided for in a satisfactory manner. All laws, rules, ordinances and regulations shall be strictly adhered to by the CONTRACTOR. The CONTRACTOR shall perform his operations so as to minimize public and commercial inconvenience.
- F. Wherever and whenever a possible public hazardous situation shall occur, the CONTRACTOR shall be responsible for whatever signing, barricades or other safety precautions are necessary to protect the public and employees on the project.
- G. No explosive shall be stored, handled or used on the project without the authorization of the ENGINEER. No unlicensed or unqualified person shall handle or use explosives, and any damage resulting from the use of explosives shall be the CONTRACTOR'S responsibility.
- H. All approved uses of explosives shall be accomplished with utmost care in order to not endanger life or property. The CONTRACTOR shall be responsible for notification of adjacent property owners, utility companies and others having property or facilities in proximity to the site. Sufficient advance notice shall be given to allow nearby property to be properly protected from damage.

#### 1.06 UTILITIES COORDINATION

- A. The contractor shall coordinate all private utility work and make provisions in the project scheduling to allow reasonable time for private utility companies to install their infrastructure.
- B. All coordination with utilities, including but not limited to water, sewer, power, gas, television, telegraph and telephone, shall be accomplished by the CONTRACTOR prior to any construction. No extra costs for damages or delay will be approved as a result of the CONTRACTOR'S failure to contact utilities or to arrange sufficient time for private utility infrastructure construction.
- C. In the event of an interruption of utilities service by his operations, the CONTRACTOR is solely responsible for repair costs and/or penalties accrued as a result of the interruptions. All planned interruptions of service shall be coordinated with the OWNER and operators, and kept to a minimum.



- D. The CONTRACTOR must follow the rules adopted by the Oregon Utility Notification Center. These rules are set forth in OAR 952-001-0010 through OAR 952-001-0090. Copies of the rules may be obtained by calling the Center at 503-232-1987 or 1-800-332-2344 or 811 before digging.

1.07 TRAFFIC CONTROL AND PUBLIC NOTIFICATION:

- A. The CONTRACTOR shall provide adequate signing, and flaggers if required, to ensure the work zone is properly identified in compliance with the current edition of the Manual of Uniform Traffic Control Devices.
- B. A detailed traffic control plan shall be supplied to the CITY at the preconstruction meeting. The plan shall include any proposed road closures and/or detour routes for the duration of construction. Closure of this roadway may be permitted for the duration of the construction excepting local traffic.
- C. The CONTRACTOR is responsible for notification of all adjacent property owners, and agencies/ companies listed below, a minimum of one week (7 days) and two days (48 hours) prior to starting work. The Contractor shall submit the notice to the Engineer for review prior to distributing by hand to the following impacted properties and agencies:

Canby Fire District  
221 S. Pine Street  
Canby, OR 97013  
Tel 503-266-5851

Candy Police Department  
1175 NW 3<sup>rd</sup> Avenue  
Canby, OR 97013  
Tel 503-655-8211

Canby Transit  
Attn: Julie Wehling  
123 NW 2<sup>nd</sup> Avenue  
Canby, OR 97013  
Tel 503-266-0751

Student Transportation of America  
Attn: Byron Searls  
1880 S. Township Rd  
Canby, OR 97013  
Tel 503-266-2064

Canby Disposal  
Attn: Amber Drevenhouer  
1600 SE 4<sup>th</sup> Ave  
Canby, OR 97013  
Tel 503-266-3900

Canby Post Office  
Attn: Jami Goodpaster  
615 NW 2<sup>nd</sup> Ave  
Canby, OR 97013  
Tel 503-266-3353

The CONTRACTOR will also be required to coordinate garbage and recycling materials collection schedule with Canby Disposal.

- D. Where, in the opinion of the ENGINEER, the CONTRACTOR has not provided suitable signs, barricades, warning lights, flag men or other suitable traffic control measures or services, or where the CONTRACTOR has not obtained suitable approvals or given proper notice as may be required in these documents or by the ENGINEER, the ENGINEER may stop that portion of the project and require the CONTRACTOR to immediately take steps to bring his work within compliance.

## 1.08 SPECIAL REQUIREMENTS

These Special Requirements supplement and amplify certain sections of the General Conditions of Construction Contract, Supplementary General Conditions, Standard Drawings and Design Drawings.

- A. The CONTRACTOR shall provide continuous access to all local residents postal deliveries as well as emergency rescue traffic. Under no circumstances may access to any resident be blocked without prearranged approval. This closure time should be kept as short as possible.
- B. The CONTRACTOR will be expected to cooperate fully in coordination with such work or additional work that may be performed by other private utility providers or other contractors. Construction Plans have been submitted to the appropriate utility providers for the purpose of service extensions or relocation of existing utilities and structures that are in conflict with the proposed construction. The cost for removing or relocating utilities will be borne by the OWNER.
- C. Existing utilities shown on the plans are from the best as-built and field information available at the time of design. The CONTRACTOR shall be responsible for having utilities marked by the appropriate agency for actual field location, if there is an apparent conflict between the new construction and existing utilities, the CONTRACTOR will be required to pothole such utilities to determine exact depth and location, provide field notes and consult with the ENGINEER for any potential conflicts prior to proceeding with the work, coordinate and schedule relocations with the appropriate utility provider. There will be no extra cost paid by the OWNER to the CONTRACTOR for attending to such incidental item.
- D. The CONTRACTOR shall be responsible for the protection of all existing facilities, remove, temporarily relocate, and replace such as mail boxes, fences, landscaping, access walks, etc. The CONTRACTOR shall also be responsible for the repair and/or replacement of existing facilities damaged by construction within a reasonable time and without any delays after the completion of the clearing and grubbing process. Payment for all protection and restoration is under the lump sum bid price listed in the bid proposal.
- E. If the CONTRACTOR or their subcontractors do not possess a current City Business Licence, They will be required to obtain one from the OWNER before the start of the work. Metro Business Licence will not be accepted as a substitute.
- F. The CONTRACTOR shall take no advantage of any errors or omissions or discrepancies on the plans. When errors or omissions or discrepancies are found, the ENGINEER shall be notified and given time to respond.
- G. The CONTRACTOR shall make all the necessary coordination and arrangements with Canby Utility for the utility trench location and street lights excavation and placement. The conduits, junction boxes and street lights will be supplied and installed by Canby

Utility crew. The CONTRACTOR will also be required to coordinate the delivery and setting of telephone manhole risers if necessary at no additional cost to the OWNER.

- H. The CONTRACTOR will be required to protect all existing trees to remain unless noted otherwise on the Construction Drawings.
- I. The CONTRACTOR shall be responsible for protection of all new concrete, asphalt surface and coordination with the residents.
- J. The CONTRACTOR will be required to install all traffic sign posts and mailbox v-loc bases plumb as directed by the Engineer or the OWNER.
- K. The CONTRACTOR will be required to remove and reconstruct all driveways as required to match the grade and the existing surface in kind to the limits as directed by the Engineer or the City in the field. All work shall also be coordinated with the individual property owners.
- L. The CONTRACTOR will be required to cooperate with the utility providers by excavating and backfilling the utility trenches, junction boxes and street light placements as required by the utility providers.
- M. The CONTRACTOR shall be responsible for continuity of sanitary sewer service to each residence during the execution of the Work and /or coordinate with the individual residents 48 hours in advance of any work. Complete the work in a timely manner as to minimize their inconvenience, inform them if an unexpected delays arise as well as the work progress status. When the service connection is completed and functional, the individual residents shall also be notified.
- N. In the event of accidental spill or overflow, immediately stop the overflow and take action to clean up and disinfect spillage. If approved by the OWNER, spillage material can be transported in a water tight containers to the OWNER'S treatment plant and discharged as directed by the plant personnel.
- O. If sewage backup occurs and enters buildings, the CONTRACTOR shall be responsible for clean-up, repair, property damage cost and claims.
- P. The CONTRACTOR shall reduce sidewalk width to minimize impact to existing trees, mail boxes or traffic signs as directed by the ENGINEER but the minimum width shall not be less than 48" from back of the curb to the back of sidewalk.
- Q. The CONTRACTOR shall confine the work at any one time to a limited reach of the project to minimize inconvenience to the residents and businesses.
- R. All landscape walls are schematically shown, the extent of the walls length and heights to be determined in the field by Engineer or the City and coordinated with the individual property Owner.

**\*\* END OF SECTION \*\***

**SECTION 01500  
CONTRACTOR FACILITIES  
AND TEMPORARY CONTROLS**

**PART 1 - GENERAL**

**1.01 WATER**

If water is used from fire hydrants, the CONTRACTOR shall maintain adequate cross connection control and coordinate with Canby Utility. Information on hydrant meter set-up is available from Canby Utility at 503-266-1156.

**1.02 SANITARY FACILITIES**

The CONTRACTOR shall provide, as a minimum, portable outside sanitary facilities for the use of the CONTRACTOR'S personnel.

**1.03 CLEANUP**

All cleanup and site restoration shall be accomplished concurrently with construction. The CONTRACTOR shall ensure that no construction debris, excess excavation, materials or other waste is left on the site.

**1.06 NOISE CONTROL**

- A. Construction involving noisy operations shall be restricted to the hours between 8:00 AM and 8:00 PM as much as possible. Noisy operations shall be scheduled to minimize their duration.
- B. CONTRACTOR shall comply with all local controls and noise level rules, regulations and ordinances which apply to any work performed pursuant to the contract.
- C. Each internal combustion engine, used for any purpose on the job or related to the job, shall be equipped with a muffler of a type recommended by the manufacturer. No internal combustion engine shall be operated on the project without a muffler.

**\*\*END OF SECTION\*\***

*This Page Intentionally Left Blank*

SECTION 01600  
MEASUREMENT AND PAYMENT

**PART 1 - GENERAL**

1.01 SUMMARY

- A. The CONTRACTOR will be compensated for all work based on the unit price or lump sum price as listed in the bid proposal on "installed complete" basis. The CONTRACTOR is expected to protect, remove, temporarily or permanently relocate and replace such items as signs, mailboxes, fences, street barricades, etc. Work items called for on the plans and not specifically listed in the bid proposal shall be considered incidental to the listed bid items. No extra payment will be made for attending to such incidental items.
- B. Excavation Quantities. Excavation yardage has been calculated to include excavation to subgrade between the face of the new curb lines or the existing edge of pavement or the existing curb lines where applicable. Excavation for curbs or sidewalks or driveways and thereafter to the lines indicated on the plans or as determined in the field by the Engineer will be paid under the unit price for each bid item. For the dense mix areas, the average excavation depth was estimated at 15".
- C. No payments will be made by the OWNER to the CONTRACTOR for materials on hand, existing pipe and fittings removal that interferes with the new construction, potholing existing utilities that are potentially in conflict with the new Work and for coordinating and scheduling all the utility efforts with the franchise utility providers as required to remove or relocate existing utilities in order to complete the proposed Work.
- D. Embankment: No special payment will be made for structural embankments to complete the work. This work will be considered incidental to the contract at no additional cost to the OWNER.

1.02 MEASUREMENT AND PAYMENT. The contract price and payment thereof shall constitute full compensation for all work incidental to the completion of the project in accordance with the plans and specifications. Measurement and payment will be in accordance with the Bid Proposal as follows:

\* **Mobilization (Item A-1)**

1. Payment. Payment includes the costs associated with mobilization to perform the work and includes bonding and insurance, equipment move-in, Contractor's office and utility hookup if applicable, and miscellaneous start-up costs. This payment item also includes all labor, equipment and material for work which is listed in the specifications and shown on the Contract Drawings and not specifically listed with other items of the Bid Schedule, and all final site restoration, grading, incidental

landscaping, etc. All costs for additional mobilization and demobilization shall be incidental.

2. Measurement. This item will be paid per lump sum and may be invoiced upon initiation of the work and equipment has been moved in. Then the total contract amount will be paid.

\* **Temporary Protection and Direction of Traffic & Temporary Signing (Item A-2)**

1. Payment. Payment includes all labor, equipment and material necessary for all costs not covered by other specific pay items in the bid proposal for furnishing, maintaining and removing traffic control devices and temporary signs required by the contract and as ordered by the Engineer. Payment includes providing and implementing a traffic control or detour plan as required by the Engineer and the City.

2. Measurement. Payment shall be made per lump sum at the bid unit price.

\* **Erosion Control and Spill Prevention Control & Countermeasure (SPCC) Plans (Items A.3, B.3 & C.3)**

1. Payment. Payment includes all the necessary labor, material and equipment needed to prevent sedimentation and other pollutants from reaching the public storm and surface water systems. The work shall include installing, repairing, maintaining and removing temporary erosion and sediment control devices for the duration of the project, such as bio bags, sediment traps, sediment basins, matting, mulching, slope drains, construction accesses, and other structural or nonstructural erosion control devices as shown on the plans or as required. The payment also includes the costs for an approved submitted SPCC plan and any SPCC measures.

2. Measurement. Payment for this item shall be made per lump sum at the bid unit price.

\* **Clearing and Grubbing / Tree Removal & Landscape Protection, Site Restoration (Item A-4)**

1. Payment. Payment includes all the necessary work to remove, clear and dispose off-site in conformance with local, state and federal regulations all trees to be removed, debris, vegetation, tree stumps removal or grinding, logs, roots, shrubs, vines, grass and weed within the construction limits, to preserve from injury or defacement such objects and vegetation as are designated to remain in place, and to transplant as needed any impacted landscape shrubs or trees larger than 36" in height. The payment shall also include costs for all labor, equipment, and materials necessary to remove the existing trees as noted on the plans or protect the existing trees to be saved. Trim all intrusive branches from trees, hedges and shrubs that conflicts with the new sidewalks to include up to 8 feet high vertical clearances or as directed by the Engineer or the Owner. Backfill and re-grade behind the sidewalks and adjacent to all

construction, place fertilizer, restore impacted irrigation lines and sprinkler heads and seed where required, bark chips, etc., to restore the existing landscaping in kind or better condition to preconstruction condition to the satisfaction of the Engineer and the Owner and to perform final clean up of the disturbed area. Place top soil material in the areas where the existing sidewalk is to be removed as indicated on the plans.

2. Measurement. Payment shall be made per the lump sum for all clearing and grubbing, tree removal and landscape protection and site restoration at the lump sum bid price.

\* **Common Excavation (Item A-5)**

1. Payment. Payment includes all labor, equipment and materials necessary to excavate to subgrade for proposed roadway between the face of the new curb lines or the existing edge of pavement or the existing curb lines where applicable. Excavation for the curbs, driveways and sidewalks improvements will be paid at the bid unit price for each item. Payment shall include all site preparation activities, including all necessary demolition to complete the proposed improvements, including but not limited to removal of existing curbs, driveways, sidewalks, asphaltic concrete surfacing and base rock, catch basins and piping within the project limits. Payment shall include costs for the removal of all demolition and excess excavation materials to an approved disposal location in conformance with local, state and federal regulations.

Where embankment is needed to achieve the grades as shown on the cross sections, clean native material shall be placed, compacted and tested in the field as directed by the Engineer. The Contractor shall include in their bid all the necessary costs for attending to this work. No payment will be made by the Owner to the Contractor for such incidental Work.

2. Measurement. Payment shall be made per in-place cubic yard at the bid unit price.

\* **Subgrade/ Trench Stabilization (Item A-6)**

1. Payment. Payment includes all labor, equipment and material excavation and removal of the unsuitable materials that can not structurally support the paved , sidewalk or driveway area or the pipe. For the street subgrade stabilization, the excavated area shall be measured from the top of the subgrade to a depth as determined by the Engineer. For sidewalks and driveways subgrade stabilization the excavated area shall be measured from the bottom of the subbase to a depth as determined by the Engineer and includes the placement of Mirafi 500X geotextile fabric. For trench stabilization, the excavated area shall be measured from the top of the bottom of the trench to a depth as determined by the Engineer. The excavated area shall be backfilled with pit-run gravel or crushed rock. The maximum stone size is four (4) inches.



2. Measurement Payment shall be made per the in-place cubic yard at the bid unit price.

\* **Saw Cut Concrete and Asphalt Concrete Pavement (Item A-7)**

1. Payment. Payment includes all labor, materials, and equipment necessary to mark and saw cut concrete and asphalt concrete pavement. No reimbursement will be made for saw cuts not approved by the Engineer or re-cut due to repair damaged saw cut edges.

2. Measurement. Payment shall be made per lineal feet of saw cut concrete or asphaltic concrete pavement regardless of the depth at the bid unit price.

\* **Install Traffic Signs and Posts (Item A-8)**

1. Payment. The payment shall include all labor, equipment and materials necessary to furnish signs, posts, V-Loc, install and plumb the new signs and posts as indicated on the Construction Drawings. Installed complete. Payment will not be made for temporary relocations required by the construction.

2. Measurement. Payment shall be made for each sign and post installed on the project, regardless of the size and kind per each at the bid unit price.

\* **Remove, Salvage & Relocate Existing Mail/ Newspaper Mail Boxes Single or Multiple (Items A-9 & A-10)**

1. Payment. The payment shall include all labor, equipment and materials necessary to temporarily remove, salvage and permanently relocate all mail boxes and newspaper boxes single or multiple as indicated on the plans, furnish new post support and V-Loc base assembly, all accessories such as bolts, nuts, washers, etc., and plumb, installed complete.

2. Measurement. Payment shall be made per each single or multiple mailbox/ newspaper boxes post support and V-Loc base completed at the bid unit price.

\* **Remove, Salvage & Relocate Existing Decorative Mail / Newspaper Boxes (Item A-11 )**

1. Payment. The payment shall include all labor, equipment and materials necessary to temporarily remove, salvage, permanently relocate and plumb all the decorative mail boxes and newspaper boxes on existing support. The payment shall also include all accessories such as bolts, nuts, washers, etc, installed complete.

2. Measurement. Payment shall be made per each removal, salvage and relocation of existing decorative mailbox/ newspaper completed at the bid unit price.

\* **Pavement Striping Continental Cross Bars or Stop Bars (Item A-12)**

1. Payment. The payment for stop and crosswalk bars include all the cost for furnishing all labor, materials, and equipment to perform pavement striping as indicated on the plans or as modified in the field and specifications. The payment shall also include the installation of striping legends, stop and crosswalk bars as shown on the Construction Plans. Any existing legend striping removal will be considered incidental and no extra payment will be made by the Owner to the Contractor for attending to such item.

2. Measurement. Payment shall be made per the square foot for stop and crosswalk bars at the bid unit price.

\* **1"-0" Crushed Rock Base (Item B-1)**

1. Payment. The payment for this item shall include all labor, equipment, and materials, furnishing, placing and compacting the crushed rock material to the limits and typical depth shown on the Plans.

2. Measurement. Payment shall be made per the square yard compacted in place at the bid unit price to the depth as indicated on the plans.

\* **Cast-in-place Concrete Structures (Items B-2 thru B-5)**

1. Payment. Payment includes all labor, materials, and equipment necessary to install cast-in-place concrete curbs and gutters, short curbs, sidewalks and driveways to the extent shown on the plans or as directed in the field by the Engineer, including excavation to subbase, placement and compaction of foundation rock, flatwork, ramps and cuts in order to complete the work including reinforcement where required. Note ADA detectable warning mats are paid under a separate item.

2. Measurement. The quantities for payment shall be the lineal foot of concrete curb and gutters, short curbs and square yards for sidewalk and driveways. All measurements are in-place after completion and acceptance of the work.

\* **Detectable Warning Tile, ADA Ramp (Item B-6)**

1. Payment. Payment includes all labor, materials and equipment necessary to install the flexible detectible warning mat to the concrete ADA ramp. Note the concrete sidewalk for the ADA ramp shall be paid under the sidewalk bid item.

2. Measurement. Payment shall be made per each 24" by 48" pad installed at the bid unit price.

\* **Gravel and Asphalt Driveway Restoration (Items B-7 & B-8)**

1. Payment. Payment includes all labor, material and equipment necessary including excavation to subbase and restore the existing gravel or asphalt driveways to the extent

shown on the plans or as directed by the Engineer, including excavation and off-site disposal, placement and compaction of 4" deep base rock in order to complete the work (Paving will be paid under ½" hot dense mix asphalt pavement).

2. Measurement. The quantities for payment shall be per the square yard of driveways at the bid price. All measurements are in place after completion and acceptance of the work at the bid unit price.

\* **Asphalt Concrete Pavement, ½" Dense Mix (Item B-9)**

1. Payment. The payment for asphalt concrete pavement shall include furnishing, placing, and compacting the asphalt concrete and adjusting existing valve boxes and all other structures to finish grade (excluding manholes), tie to existing driveways and any miscellaneous repairs including furnishing and placing asphalt tack coat along existing edge of pavement at sawcut lines, new curb lines and match line joints, as specified herein, or as directed by the Engineer.

2. Measurement. Payment shall be made per the ton at the bid unit price.

\* **Precast Concrete Manorstone Block Retaining Walls (Item B-10)**

1. Payment. The payment shall include all labor, material and equipment necessary to excavate and haul excess material off-site, prepare foundation and leveling pad, place block units and caps identified on the plans or as directed and restore the area to match the existing condition or better and to the satisfaction of the Engineer, City or property owner.

2. Measurement. Payment shall be made per square foot of the vertical face of the walls at the bid unit price.

\* **Minor Existing Manhole/ Cleanout Adjustment To New Grade (Item B-11)**

1. Payment. Payment includes all labor, materials, and equipment necessary to excavate, dispose excess materials, add riser rings or remove riser rings to meet the new finish surface grade. The payment shall also include placement and compaction of select backfill material. Existing water valve adjustments will be considered incidental work at no payment will be made by the Owner to the Contractor.

2. Measurement. Payment shall be made per each item at the bid unit price.

\* **Trench Excavation, Pipe Installation, & Backfilling (Item C-1)**

1. Payment. The payment shall include all labor, equipment and material to excavate and disposal of all excess material, pipe bedding, pipe by dimension and type, pipe zone material, backfill, compact and testing as required. Installed complete.

2. Measurement. Payment shall be made per the lineal foot at the bid unit price.

\* **Remove Existing Catch Basins (Item C-2)**

1. Payment. Payment includes all labor, material and equipment necessary to excavate, dispose of excess material, saw cut pipe and plug with concrete, remove existing catch basin and dispose off-site, place and compact crushed rock.

2. Measurement. Payment shall be made for each completed in place catch basin removal regardless of the depth at the bid unit price.

\* **Type G-2 Catch Basins, Waite Concrete Catch Basins & 48" Diameter Drywells (Items C-3 thru C-5)**

1. Payment. Payment includes all labor, material and equipment necessary to excavate, dispose of excess material, place and compact base rock, furnish and install the structure with a minimum of 18" sump for catch basins and dry wells, sawcut, connect inlet and outlet pipes, place and compact granular backfill, and test for quality control. Payment shall include water tight pipe connection, cast iron frames and covers, sawcut pipe and plug existing pipe with concrete when constructing catch basin over existing pipe. Installed complete.

2. Measurement. Payment shall be made for each completed in place G-2 catch basin or waite concrete catch basin regardless of the depth and 48" diameter drywells at 26 feet deep at the bid unit price.

\* **Connect to Existing Drywell (Item C-6)**

1. Payment. Payment includes all labor, material and equipment necessary to excavate, remove existing pipe and dispose excess material off-site, core existing drywell wall to enable new pipe connection, grout around pipe connection as appropriate. Payment shall include water tight pipe connections. Installed complete.

2. Measurement. Payment shall be made at the bid unit price for each completed in place drywell connection.

\* **6" Cleanout Construction Over Existing Sanitary Sewer Service Lateral (Item D-1 )**

1. Payment. Payment includes all labor, material and equipment necessary to excavate, dispose of excess material, expose and sawcut existing 6" concrete pipe, furnish and install concrete to PVC adaptors and fittings as needed, 6" cleanout assembly, frame and lid, etc., place and compact granular backfill. The length of the lateral shall be replaced to the extent of the 4" connection on the customer side if agreed by the property owner. The Contractor will be required to coordinate such connection with the property owner upon exposing the pipe.

2. Measurement. Payment shall be made for each structure completed in place regardless of the depth (estimated 5' to 11'), at the bid unit price.

\* **6" Sewer Service and Cleanout (Items D-2 & D-3)**

1. Payment. The payment for this item shall include all labor, materials, and equipment necessary to excavate, dispose excess materials, install Romac saddle, 6" lateral pipe and 6" cleanout at the property lines as shown on the detail. The payment shall also include compaction and trench backfill with granular material in the traveled area and native material outside the paved area.

2. Measurement. Payment shall be made per each completed in place service at the bid unit price.

\* **Remove, Salvage & Cap Exist 6" Fire Hydrant Valve (Item E-1)**

1. Payment. The payment for this item includes all labor, material and equipment necessary to remove, salvage the existing fire hydrant, remove the existing spool and installing a blind flange at the existing hydrant valve, closing the valve, filling the valve box with concrete and backfilling the trench with crushed rock and compacting.

2. Measurement. Payment shall be made for each completed in place fire hydrant removal and capping at the bid unit price.

\* **Install Existing 6" Fire Hydrant Assembly (Item E-2)**

1. Payment. The payment for this item includes all labor, material and equipment necessary to install the existing fire hydrant including 12"x6" hot tap, 6" gate valve, valve box and cover, 6" pipe spool (length as required) with restraint, drain gravel, pier block, 5" storz adaptor, using the salvaged 6" fire hydrant and poring concrete collar around the hydrant. The cost shall also include exposing the waterline trench approximately 10 feet on each side of the hot tap to allow for flexing the power wiring/conduits.

2. Measurement. Payment shall be made for each completed in place fire hydrant at the bid unit price.

\* **1" Water Service Connection (Items E-3 & E-4)**

1. Payment. The payment shall include all labor, materials and equipment necessary to excavate and dispose excess material associated with the work, back fill the trench with select backfill and compact, direct tap connection to existing 12" PVC C900 using saddle strap, install 1" PET tubing (length as required), corporation stops, angle meter, and new meter box. Installed complete.

2. Measurement. Payment shall be made for each completed in place 1" water service connection at the bid unit price.

\* **1 1/2" Water Service Connection (Item E-5)**

1. Payment. The payment shall include all labor, materials and equipment necessary to excavate and dispose excess material associated with the work, back fill the trench with select backfill and compact, direct tap connection to existing 12" PVC C900 using double saddle strap, install 1 1/2" PET tubing (length as required), corporation stops, angle meter and new meter box. Installed complete.

2. Measurement. Payment shall be made for each completed in place 1" water service connection at the bid unit price.

\* **Excavate and Backfill for Street Lights (Item F-1)**

1. Payment. The payment shall include all labor, material and equipment necessary to excavate for street lights and place select material backfill to grade. Street light pole will require five (5) feet of compacted 3/4" crushed rock backfill around hole excavated by the Contractor. It shall also include all the necessary coordination with the appropriate utilities to complete their work.

2. Measurement. Payment shall be made per each completed in place street light pole at the bid unit price.

**\*\*END OF SECTION\*\***

*This Page Intentionally Left Blank*

**SECTION 01700  
PROJECT CLOSEOUT**

**PART 1 - GENERAL**

1.01 FINAL CLEANUP

Prior to final acceptance the CONTRACTOR shall clean, remove all refused and unused materials resulting from the work activities within the project limits.

1.02 FINAL SUBMITTAL

Prior to final acceptance, the CONTRACTOR shall provide:

1. A written certificate that all work has been fully completed in accordance with the plans and specifications, and requesting final inspection.
2. A complete set of red-lined as-constructed drawings to the ENGINEER showing all deviations from the design plans.

Prior to final acceptance, the CONTRACTOR shall execute and provide all the necessary supporting documents for the following forms. Forms will be provided by the ENGINEER:

- a. Consent of Surety to Final Payment.
  - b. Contractor's Affidavit of Payment of Debts and Claims.
  - c. Contractor's Affidavit of Release of Liens.
3. Final invoicing.

1.03 WARRANTY

The warranty period on all the work shall be 12 months from the date of final acceptance by the OWNER.

**\*\* END OF SECTION \*\***



*This Page Intentionally Left Blank*

**DIVISION 2 - SITEWORK**

DIVISION 2 - SITEWORK

**SECTION 02100  
SITE PREPARATION**

**PART 1 - GENERAL**

**1.01 DESCRIPTION**

This section includes labor, materials, equipments and provisions for demolition and disposal of all objectionable material and related work necessary to prepare the site for construction operations. All work shall be in conformance with 2018 ODOT/APWA Standard Specifications for Construction. except as modified herein.

**1.02 COORDINATION**

A. The CONTRACTOR shall coordinate his operations with affected property owners and utilities likely to be impacted by construction. A partial listing of agencies and utilities follows:

1. Canby Public Works Department, Mr. Jerry Nelzen, (971) 253-9173
2. Canby Utility Electrical; Mr. Gary Stockwell (503) 263-4307, Cell (971) 563-6307
3. Canby Utility Water; Mr. Bill Makowski (503) 263-4309 or Cell (971) 563-6315
4. Canby DirectLink; Mr. Matt Downs (503) 266-8252 or Cell (503) 341-4357
5. Wave Broadband; Mr. Travis Edge (503) 899-3267
6. NW Natural; Mr. Darrel Hammond (503) 585-6611 Ext 8035 or Cell (503) 981-0164
7. One Call Notification Center; Phone (800) 332-2344 Or 811

B. The CONTRACTOR shall be responsible for coordinating his activities with affected utilities and property owners and other adjacent contractors. No additional costs are allowed for delays resulting from a lack of such coordination by the CONTRACTOR.

**1.03 PROPERTY PROTECTION**

A. All structures, utilities, and properties, whether inside or outside the project limits, shall be protected from damage or interruption by the CONTRACTOR'S activities. Responsibility for safety and protection of buildings near or in the project limits are the CONTRACTOR'S. The CONTRACTOR shall repair or replace damaged structures, utilities, and/or properties to the satisfaction of the OWNER.

- B. The location of underground utilities; power, telephone, cable, gas, etc., if shown on the Design Drawings are approximate. The actual locations may vary from those shown. The CONTRACTOR is responsible for verifying all utility locations. No extra costs are allowed for delays resulting from utility conflicts for which the CONTRACTOR is responsible. On questions regarding the disposition of existing utilities, improvements or buildings, the CONTRACTOR shall contact the ENGINEER for advisement.

## **PART 2 - PRODUCTS (NOT USED)**

## **PART 3 - EXECUTION**

### **3.01 DEMOLITION**

- A. Demolition will be as shown on the Drawings, or as required to accomplish the work.
- B. All pavement or concrete walks to be removed will be saw cut in straight clean lines.

### **3.02 DISPOSAL OF WASTE MATERIAL**

Waste material shall be disposed of off-site by the CONTRACTOR in accordance with all federal, state, and local regulations.

**\*\*END OF SECTION\*\***

**SECTION 02200  
EARTHWORK**

**PART 1 - GENERAL**

1.01 DESCRIPTION

This section includes all labor, materials, equipment and methods to be used to perform all excavation, foundation preparation, backfilling, slope stabilization, roadway embankment and compaction required as shown on the Drawings in conformance with 2018 ODOT/APWA Standard Specifications for Construction.

**PART 2 - PRODUCTS**

2.01 FOUNDATION MATERIAL

Foundation material shall be native material except where ground water or other adverse conditions exist, which **in the opinion of the ENGINEER**, cannot support the structure or pipe. In those conditions, foundation material shall be select backfill.

2.02 BEDDING AND PIPE ZONE MATERIAL

The pipe bedding and pipe zone material shall be crushed rock with a maximum size of 1-1/2", uniformly graded from coarse to fine. The materials shall predominate in the fine sizes and shall present no isolated points which would cause fracture or damage to the pipe. All materials shall be in conformance with 2018 ODOT/APWA Standard Specifications for Construction and shall be subject to the ENGINEER's approval.

2.03 NATIVE BACKFILL

Native backfill shall be native material which is free of organic materials, nonplastic (no clay), reasonably evenly graded and capable of being compacted with 100% of the material passing a 1" screen.

2.04 SELECT BACKFILL

All select backfill shall be crushed rock with a maximum size of 1-1/2", uniformly graded from coarse to fine, complying with the requirements of the 2018 ODOT/APWA Standard Specifications for Construction. All materials shall be subject to the ENGINEER's approval.

2.05 EMBANKMENT

The CONTRACTOR shall provide for embankment crushed rock material with a maximum size of 4" pit run rock, uniformly graded from coarse to fine, complying with the requirements of the 2018 ODOT/APWA Standard Specifications for Construction. All materials shall be subject to the ENGINEER's approval.

## PART 3 - EXECUTION

### 3.01 GENERAL

- A. The CONTRACTOR shall perform all excavation of every description and of whatever materials encountered to the depth indicated on the Drawings or as specified below.
- B. The CONTRACTOR shall make proper allowance for the pipe thickness, pipe bedding and, if required, foundation stabilization.

### 3.02 PREPARATION

- A. As specified in Section 02100, Site Preparation, clearing and grubbing shall be completed and existing pavement shall be removed prior to excavating soils.
- B. Erosion Control
  - 1. The CONTRACTOR is responsible for developing and maintaining an erosion control plan to prevent the transport of soil off-site via wind or rain for the duration of the project. The erosion control measures shall remain in place until all vegetation is established.
  - 2. Best Management Practices shall be utilized to control runoff at the site and to protect existing and proposed storm drain facilities. These methods include but are not limited to: hay bails, bio bags, silt fences, berms, stockpile covers, gravel construction entrances, etc. Erosion control measures shall be in conformance with local, state, and federal regulations.
  - 3. Temporary erosion control measures shall be provided until the placement of permanent features and/or the establishment of grass. The temporary erosion control measures shall include ground cover or other acceptable means of all disturbed areas caused by the CONTRACTOR'S activities. Temporary erosion control measures shall be in conformance with local, state, and federal regulations.

### 3.03 COMMON EXCAVATION

- A. Excavations shall be classified as either common or rock excavation.
- B. Common excavation is defined as the removal of all material which is not classified as rock excavation.
- C. The limits of excavation shall be kept to a minimum.

- D. The CONTRACTOR shall take necessary precautions to prevent damage to adjacent structures or utilities.
- E. Sheeting and shoring may be necessary or may be required by regulatory authorities in accordance with safety laws.
- F. CONTRACTOR shall also make provisions to prevent soil or water intrusion into the pipelines prior to completion of installation.

#### 3.04 EMBANKMENT CONSTRUCTION

- A. Embankment construction shall include preparation of the areas upon which embankments are to be placed as shown on the construction plans. Placement of fill materials to be performed after the area receiving fill has been stripped from all organic and foreign material.
- B. The CONTRACTOR shall place embankments and fills in horizontal layers of 12 - 18 inches maximum depth and compact each layer to a minimum of 95% of maximum density per AASHTO T-180 standards or approved equivalent.

#### 3.05 ROCK EXCAVATION

- A. Rock excavation is defined as a method of removal and not a geological formation, and includes removal of solid material, that in the opinion of the ENGINEER, cannot be removed by nominal 60,000 pound excavating equipment available to the CONTRACTOR in common use for the type of project undertaken, AND requires for its removal drilling and blasting, wedging, sledging, barring or breaking up with additional powered equipment.

No material that can be removed with a power operated excavator of 60,000 pound capacity with rip tooth or similar attachment will be defined as rock excavation.

- B. Boulder removal may be classified as open trench rock removal if at least one dimension of the removed boulder is greater than 3 feet. Concrete and reinforced concrete pipes, structures, thrust blocks or fill required to be removed or demolished will not be considered rock excavation.
- C. Limits of payment for rock excavation shall be in-place cubic yard defined as a maximum of pipe outside diameter plus 30" in width, from the observed level of rock to a trench invert 6" below the pipe invert in depth, and length defined by the extent of the rock. Boulder excavation will be based on the volume of the boulders removed.



### 3.06 PIPE TRENCHES

- A. It is the intent of these specifications that the excavation and/or trench width at the surface of the ground be kept to a minimum necessary to install the pipe in a safe manner. In all cases, excavations or trenches must be of sufficient width to allow for shoring, if required, and permit proper joining of the pipe and backfilling of material along the sides of the pipe. The CONTRACTOR shall exercise special care when construction is adjacent to existing structures to avoid damage.
- B. The length of the trench excavated shall always be kept to a minimum. The ENGINEER shall be the sole judge of the amount of open trench allowed based upon work conditions of the area. In normal cases, the open trench length shall not exceed 200 feet.
- C. The CONTRACTOR shall excavate the trench to the lines and grades shown or as established by the ENGINEER, with proper allowance for the pipe thickness, pipe bedding and foundation stabilization as required. The subgrade upon which the bedding is to be placed shall be firm, undisturbed and true to grade. If the trench is over-excavated, the CONTRACTOR shall restore it to grade with pipe bedding material and compact material as specified for bedding, all at no expense to the OWNER.

### 3.07 FOUNDATIONS

- A. When, in the judgement of the ENGINEER, the existing material in the excavation is unsuitable for support, the CONTRACTOR shall excavate below grade, as directed in writing. The CONTRACTOR shall backfill the excavation to subgrade with foundation material and compact in layers not exceeding six inches deep. The foundation material in the trench shall be compacted by machine operated pneumatic or mechanical tampers. Compaction shall be approved by the ENGINEER. Unsuitable foundation material shall be disposed of at an approved site.
- B. No unsuitable material has been identified on-site. Any foundation material required will be paid under a negotiated change order, if required.

### 3.08 DEWATERING

- A. Removal and disposal of storm water from the excavation shall be the responsibility of the CONTRACTOR as approved by the ENGINEER. Such approval shall not imply any liability of the ENGINEER or OWNER for damage or extra costs incurred by the CONTRACTOR in handling or disposing of storm or runoff surface water.
- B. Groundwater
  - 1. Contractor shall perform dewatering as needed to complete the construction. Costs for dewatering activities shall be considered incidental to the contract.

2. Water generated from dewatering activities shall be properly disposed of in accordance with the requirements of the Contract Documents, herein, and local, state, and federal regulations.

### 3.09 HANDLING EXCAVATED MATERIAL

All excavated material not required for backfilling or embankment on-site shall be promptly removed and disposed off-site by the CONTRACTOR in accordance with governing regulations.

### 3.10 PIPE BEDDING AND ZONE MATERIAL

- A. Pipe bedding consists of leveling the bottom of the trench or the top of the foundation material and placing bedding material to the horizontal centerline of the pipe. Bedding material shall be as specified hereinbefore and as shown on the plan and placed in at least two lifts. Place the first lift to provide the minimum depth of bedding material as shown in the Contract Drawings before the pipe is installed. The CONTRACTOR shall spread the bedding smoothly to proper grade so that the pipe is uniformly supported along the barrel and excavate bell holes at each joint to permit proper assembly and inspection of the entire joint. Bedding under the pipe shall provide a firm, unyielding support along the entire pipe length. Particular attention must be given to the area from the flow line to the horizontal centerline of the pipe to insure that firm support is obtained to prevent any lateral movement of the pipe during the final backfilling of the pipe zone. Pipe bedding shall be placed the full width of the trench and shall be a minimum of 6 inches in compacted depth below the pipe.
- B. The CONTRACTOR shall place the specified pipe zone material carefully around the pipe. The CONTRACTOR shall prevent pipe from movement either horizontally or vertically during placement and compaction of pipe zone material. The pipe zone material shall be a minimum of 12 inches in compacted depth above the pipe.

### 3.11 BACKFILLING

- A. The CONTRACTOR shall take reasonable precautions to prevent any native backfill material from becoming saturated beyond the critical moisture limits.
- B. Take all necessary precautions to protect the structure or pipe from any damage, movement or shifting. Take special care when compacting materials adjacent to existing structures to avoid damage.
- C. Trench backfill shall be select material in all areas under sidewalks and AC surfacing or in areas identified for structural fill.
- D. All excavations and trenches shall be backfilled in maximum 12 - 18 inch lifts to the densities described below.

1. Native backfill material shall be compacted to a minimum 90% of maximum density as determined by AASHTO T-180. Backfill shall terminate below finish grade to allow for placement of top soil.
2. Select backfill material shall be compacted to a minimum 95% of maximum density as determined by AASHTO T-180. Backfill shall terminate below finish grade to allow for placement of AC or concrete.

### 3.12 TESTING

- A. The OWNER will employ an independent testing company to determine moisture content and in-place density of soils by any one or combination of the following test methods:

Moisture-density curve	AASHTO T-180 (ASTM D-1557)
------------------------	----------------------------

In-place density by nuclear methods	AASHTO T-238 (ASTM D-2922)
--	----------------------------

Moisture content by nuclear methods	AASHTO T-239 (ASTM D-3017)
--	----------------------------

- B. The frequency of testing will be adequate to assure the ENGINEER of compliance with the contract requirements. As a minimum, in place density and moisture testing shall be completed once for each lift of backfill material incorporated into the work. A minimum of one moisture density test shall be completed, and at least one additional moisture density test shall be completed for each significant change in backfill materials.
- C. The CONTRACTOR shall cooperate with testing efforts by leveling small test areas designated by the ENGINEER and shall backfill test areas, all at the CONTRACTOR'S sole expense.
- D. The OWNER will be responsible for all passing test costs. Any work showing noncompliance with test standards shall be repaired or replaced and retested at CONTRACTOR'S expense until in compliance with specified standards.

**\*\*END OF SECTION\*\***

**SECTION 02500  
PAVING AND SURFACING**

**PART 1 - GENERAL**

1.01 DESCRIPTION

- A. This section covers the work and materials for furnishing and installing Portland Cement Concrete and Asphaltic Concrete surfaces where shown on the Drawings and as necessary to replace existing surfaces disturbed by construction activities. All work shall be in conformance of 2018 ODOT/APWA Standard Specifications for Construction.
- B. This section also covers the work and materials necessary for signing and placement.

1.02 QUALITY ASSURANCE

Work provided under this section shall conform to 2018 ODOT/APWA Standard Specifications for Construction.

**PART 2 - PRODUCTS**

2.01 BASE COURSE MATERIAL

Base course material shall be crushed rock aggregate with a maximum size of 1" minus, uniformly graded from coarse to fine. All materials shall be comply with section 02630.10 of the 2018 ODOT/APWA Standard Specifications for Construction.

2.02 ASPHALT CONCRETE PAVEMENT

Asphaltic Concrete shall be ½" Dense Asphaltic Concrete Pavement (HMAC) complying with the requirements of the 2018 ODOT/APWA Standard Specifications for Construction. The mix shall be level 2 Performance Grade (PG), 64-22 binder.

2.03 CURBS, SIDEWALKS AND DRIVEWAYS

- A. Concrete materials shall conform to the requirements of the 2018 ODOT/APWA Standard Specification for Construction, Section 00759.
- B. Commercial Grade Concrete shall be minimum 3,000 psi compressive strength at 28 days in conformance of 2018 ODOT/APWA Standard Specifications for Construction, Section 00440.

## 2.04 ADA TRUNCATED DOME TEXTURE

- A. ADA ramps shall comply with the requirements the Americans with Disabilities Act. Place truncated dome detectable warning texture 2' x 4' in the lower throat of the ramp only. Arrange domes using in-line pattern only. Color shall be safety yellow.
- B. Mats shall be cast-in-place. Cast-in-place tiles shall be shall be Armor-Tile Vitrified Polymer Composite (VPC) product, telephone 1-800-682-2525.

## 2.05 MAILBOXES

All mailbox posts shall be new single or multiple as required, and shall be of 2" nominal thin walled formed tube as shown on the plans. The Contractor shall be responsible to relocate/install all boxes to the new supports.

## 2.06 RETAINING WALLS

- A. Modular concrete retaining walls shall be constructed of precast concrete blocks with straight or curved split face, solid top surface and integral lip for aligning multiple layers. Blocks shall be antique blend or gray color as specified or to match the existing and nominally 16" wide x 6" tall x 12" deep. Blocks shall be Manorstone Retaining Wall Blocks as Distributed by Mutual Materials Company, or equal. Wall shall be constructed in accordance with the manufacturers's guidelines and as shown on the plans.
- B. Base Leveling Pad Material - Material shall consist of compacted angular sand, crushed stone or leveling non-reinforced concrete.

## 2.07 SIGNS AND SIGN POSTS

- A. All sign materials shall be engineer-grade reflective sheeting on .080 aluminum blanks with radius corners and standard drilling where required conforming to ODOT/APWA 2008 Standard Specifications for Construction and the Manual on Uniform Traffic Control Devices, latest edition. STOP signs shall be high-intensity (diamond-grade) reflective sheeting.
- B. All sign posts shall be a minimum of 2 x 2- inch galvanized "unistrut's telespar" or 12-gauge perforated posts or approved equal. All new posts shall be set with a V-LOC base provided by the CONTRACTOR as shown on the plans. V-Loc shall be Tapco, model 200-VS2
- C. A 2 x 2-inch, 14-gauge galvanized "unistrut's telespar" or 12-gauge perforated posts or approved equal shall be used when a combination of signs is more than 36 inches in height. Sign post is 2-inch square tubing and must be embedded a minimum of 12 inches into the base. V-lock base wedges will be provided by the CONTRACTOR.

## 2.08 GEOTEXTILE FABRIC

All geotextile fabric material for subgrade shall be Tencate Mirafi 180N, 500X, Propex Geotex 801, US Fabrics US 205NW or approved equal.

## 2.09 PAVEMENT STRIPING

Thermoplastic products shall be from the latest qualified product list as published by ODOT. All legends such as crosswalks, stop bars, bike stencils and arrows shall be type "A" liquid, hot-applied thermoplastic or preformed type "B" thermoplastic film with intermixed traffic paint beads. All installations shall be in accordance with 2018 ODOT/APWA Standard Specifications for Construction, section 00865. Painted striping or legends will not be permitted.

## PART 3 - EXECUTION

### 3.01 BASE COURSES MATERIAL

All base and leveling courses shall be compacted to a minimum density of 95% maximum density as determined by AASHTO T-180 and installed in accordance with the requirements of the ODOT/APWA 2008 Standard Specifications for Construction, section 00640.

### 3.02 ASPHALT CONCRETE PAVEMENT

- A. Preparation, placement and testing shall comply with the 2018 ODOT/APWA Standard Specifications for Construction, Section 00744 and 00745, Asphaltic Concrete Pavement.
- B. Mixture shall be machine laid, as practicable, by experienced workman on a compacted crushed rock base. Special care shall be taken to avoid segregation of materials and to maintain specified grades, thickness and smoothness.
- C. All valve boxes, manhole frames, catch basin gratings and other utility appurtenances located within paved areas shall be set or raised to finish grade, unless otherwise noted. All surfaces shall be tack coated prior to paving.
- D. The final surface shall be smooth, true to grade, free draining and free of all surface defects.
- E. Repairs to cut or damaged asphaltic concrete surfaces shall be repaired as follows:
  - 1. All AC surfaces shall all be saw cut. All edges shall be sealed and sanded upon completion.
  - 2. Unless directed otherwise by the ENGINEER, the new pavement shall have the same plan grade as the pavement that existed prior to construction.

3. Patches shall conform to adjacent existing pavement and provide a smooth, continuous surface.
- F. Scheduling- The CONTRACTOR shall schedule the construction activity to provide a minimum of 10 days notice to the OWNER, and accomplish all work within the specified performance period.
- G. The exact limits of pavement removal shall be determined in the field by the OWNER. The CONTRACTOR shall cut the pavement to the depth of removal around the perimeter of the area to be removed. Cuts shall be made with a power saw or other approved methods that leaves a straight and vertical face.
- H. After cutting, existing pavement shall be excavated as required. Any damage to adjoining pavement or the underlying base course, as a result of either the cutting or removal operation, will be repaired by the CONTRACTOR at no cost to the OWNER.
- I. Excavate and dispose all existing asphalt and base course in a permitted waste disposal site. Disposal must be according to federal, state and local regulations.
- J. Before replacement of the asphalt surface , apply a tack coat to all vertical surfaces of the existing pavement and allow the tack coat to cure. Compact the newly replaced asphalt surface with a vibratory compactor, either by hand or by rolling to achieve a smooth, uniform surface level with the adjoining pavement.
- K. HOT MIX ASPHALT CONCRETE (HMAC) TESTING: The CONTRACTOR will be required to employ an independent testing company to obtain specimens and complete extraction/ gradation and maximum specific gravity (rice) test on the HMAC. This test may be waived by the ENGINEER upon pre-approval if the Job Mix Formula (JMF) for the specified mix type, broadband limits and tolerances are found to be in conformance with the 2018 ODOT/APWA Standard Specifications for Construction. The CONTRACTOR will also be required to provide adequate passing compaction tests at the frequency of five (5) tests per 1,000 tons of HMAC. Compaction testing shall be performed on each lift of HMAC. A minimum of two (2) tests or one (1) test per each lift will be required on smaller projects (where the HMAC quantity is less than 1,000 tons) as directed by the ENGINEER. The testing method shall conform to ODOT TM 305 or AASHTO T 209. All testing costs will be at the sole expense of the CONTRACTOR.

### 3.03 CURBS, SIDEWALKS AND DRIVEWAYS

- A. Curbs, sidewalk and driveway construction shall comply with the requirements of the ODOT/APWA 2008 Standard Specifications for Construction.
- B. Contraction joints spacing to be no more than 15 feet. It shall be 1/3 the concrete thickness, but not less than 1/8" nor more than 1/4" wide.
- C. Sidewalk and Driveway panels shall be tooled into 5 foot panels.

- D. Surface finish shall be true and straight, free from humps, sags or other irregularities.
- E. Cure concrete by covering with burlap, canvas, sand or other acceptable material and keep moist for a sufficient amount of time to avoid cracking. Curing compounds may be used if applied immediately to the concrete surfaces or reinforcement that will come in contact with adjacent concrete pours.
- F. All flat work shall be scored in 5 foot squares typical, and finished with a small radius tool, with 1 ½ to 2" troweled shiner on all four edges of each panel, including at the curb line and back line of walk. Finish field with light broom finish.

#### 3.04 ADA TRUNCATED DOME TEXTURE

- A. During surface preparation and mat installation procedures ensure that the installation meets all safety guidelines in accordance with the applicable industry and government standards.
- B. All truncated dome materials shall be installed in strict accordance with the guidelines set by the manufactures.

#### 3.05 MAILBOXES

All mailboxes shall be located in the new sidewalks, flushed with the face of the curb and extend between 30" to 36" above the top of the curb. The minimum pedestrian clear path shall be a minimum of 48".

#### 3.06 RETAINING WALLS

- A. Block walls to be installed by the CONTRACTOR, in accordance with the manufacturer's requirements. The installation may require more or less blocks to achieve the goal of supporting the side slopes. Top Blocks shall be backfilled with native soil to follow general grade of sidewalk.
- B. Excavation- CONTRACTOR shall excavate to the lines and sidewalk grades shown on the construction drawings. The ENGINEER shall inspect the excavation and approve prior to the placement of leveling material.
- C. Base Leveling Pad Material - Material shall consist of compacted angular sand, crushed stone or leveling non-reinforced concrete. The leveling pad shall be prepared to insure full contact with the base surface of the concrete block units.
- D. Over-excavation of deleterious soils and replacement with suitable materials will be paid at the unit price for "Subgrade Stabilization".



3.07 GEOTEXTILE FABRIC

All geotextile fabric material for subgrade shall be laid straight along the subgrade allowing 6-inches minimum overlap over existing fabric panel.

3.08 SIGNS & POSTS

All sign heights and locations shall conform with the requirements of 2018 ODOT/APWA Standard Specifications for Construction and the Manual on Uniform Traffic Control Devices, latest edition and shall be inspected by the City.

3.09 PAVEMENT STRIPING

- A. All striping shall comply with the requirements of 2018 ODOT/APWA Standard Specifications for Construction.
- B. All pre-markers for pavement markings shall be laid out in the field by the CONTRACTOR and approved by the CITY or ENGINEER prior to final placement of striping or symbols.

**\*\*END OF SECTION\*\***

**SECTION 02700  
SITE PIPING**

**PART 1 - GENERAL**

1.01 DESCRIPTION

- A. This section includes purchase, storage, installation and testing of all underground piping including but not limited to sanitary sewers, storm drains and water pipes.
- B. All waterline construction shall comply with the Oregon Chapter of the American Water Works Association (AWWA) and **Canby Utility Water System Standard Specifications**, which are available from Canby Utility and incorporated by reference. Canby Utility will inspect construction of all public water system improvements.
- C. All water work construction shall comply with the requirements of Oregon Administrative Rules, Chapter 333, Division 61, "Public Water System" latest edition or current revision, as amended herein.
- D. The CONTRACTOR shall coordinate with Canby Utility Operations Supervisor on all construction activities impacting operations of the water system or impacting service to private properties.
- E. When pipelines cross existing utilities such as sanitary sewer, water, gas, telephone, electric or cable, the CONTRACTOR shall pothole to verify elevations prior to construction. The ENGINEER shall be notified of any conflicts and modify the design as required without additional cost to the OWNER.

1.02 QUALITY ASSURANCE

Work within this section shall conform to the 2018 ODOT / APWA Standard Specifications for Public Works Construction unless otherwise noted herein.

**PART 2 - PRODUCTS**

2.01 PIPE MATERIALS

- A. Polyvinyl Chloride (PVC) Pipe for gravity sewers 4"-12" shall be ASTM C3034, SDR 35. Gaskets shall conform to the requirements of ASTM F-477 and ASTM 3212.
- B. Polyvinyl Chloride (PVC) Pipe for pressure waterlines 4" thru 12" shall be meeting ASTM-D 1784, AWWA C-900 Pressure Class 235 DR18 with elastomeric gasket seal meeting the requirements of ASTM F477. Gaskets joints shall conform to the requirements of ASTM D3139.

- C. Ductile Iron (DI) Pipe shall be minimum Class 52, meeting the requirements of AWWA Standard C-151 and shall have a cement-mortar lining and bitumastic seal coating meeting the requirements of AWWA Standard C104. Joints shall be rubber gasket flexible restrained joint per AWWA C-111.

## 2.02 PIPE FITTINGS

- A. All fittings shall be of comparable pressure rating and construction as the main pipeline material and must be approved by the National Sanitation Foundation (NSF) in accordance with OAR 333-061-0087.
- B. Fittings for ductile iron pipe shall meet the requirements of AWWA C-110 standard fittings or AWWA C-153 compact fittings and of domestic origin and shall have a minimum working pressure rating of 250 psi. Joints shall meet the requirements of AWWA C-111. End configuration to be mechanical joint or flanged. Fittings shall be cement mortar lined and bitumastic seal coated, meeting the requirements of AWWA C-104. Gaskets for flat faced or raised faced flanges shall be 1/8 inch thick neoprene having a Durrometer reading of 60, plus or minus 5. The type, material and identification mark for bolts and nuts shall be provided.
- C. All Valves shall be resilient wedge gate valves conforming to AWWA C-509, cast iron, epoxy-coated per AWWA C-550, NRS, rated for 200 psi working pressure for pipe 2 inches to 12 inches in diameter.
- D. Water Service Lines shall be 1" Polyethylene (PET) tubing, conforming to AWWA C-901, SDR 9, ANSI/NSF 61, blue in color and Canby Utility specifications. All service lines shall have a 14 or 16 gauge insulated tracer wire from the mainline to the meter, with blue polyethylene insulating sheathing.
- E. Water Service Lines 1 1/2" and 2" shall be rigid copper tubing, type "K", hard drawn, conforming to the requirements of ASTM B-88 or (SDR 9) 2" Polyethylene (PET) tubing (CTS) blue in color, conforming to AWWA C-901, ANSI/NSF 61 and Canby Utility specifications. All non-metallic service lines shall have a 14 or 16 gauge insulated tracer wire from the mainline to the meter, with blue polyethylene insulating sheathing.
- F. Service connection installation, Direct taps shall be 1" corporations with CC thread and approved compression connection. Saddled connections shall consist of stainless steel strap with nylon or epoxy coated ductile iron body conforming to AWWA C-800 requirements. 1" saddles shall be single strap and IPT. 1 1/2" or 2" saddles shall be double strap and IPT. Sized bronze saddles are required on PVC main lines.
- G. Meter stops shall be angle pattern with locking wing compression coupling by meter swivel nut, brass body ball style conforming to the requirements of AWWA C-800. 1" valve shall be Mueller style model B-24258, 1 1/2"-2" shall be Mueller style model 107B-2423-2-17.

- H. Meter boxes shall be the DWF Plastics Inc., DWF486WBC-12-1M Body. H-20 rating with DWF Plastics, Inc C-4M Lid Grey Solid Meter Box Cover with magnet 11"x18" Polymer H-20 rating.
- I. Corporation stops shall be iron pipe thread or CC thread by compression coupling, brass body, ball style conforming to the requirements of AWWA C-800. 1"-2" valves shall be Mueller style model B-250258, B-25008, 1 ½" -2" or approved equivalent.

## 2.03 PIPELINE MATERIAL DESIGNATIONS

- A. Except as designated or modified in these Specifications, pipelines shall be constructed with the materials designated in the Drawings.
- B. The materials specified herein shall establish the type and level of standard for comparable substitution. All waterline materials shall be as specified or equal as determined by Canby Utility.

## 2.04 THRUST RESTRAINT

- A. All pressure rated pipelines shall have thrust restraint systems capable of restraining a minimum of 150 psi maximum line pressure.
- B. Mechanical thrust restraint systems shall consist of mechanical thrust restraint devices placed at fitting and pipe joints as necessary to accommodate the designated line pressure. Mechanical thrust restraint devices shall be standard 125 pound flanges, MJ Gripper Glands by U.S. Pipe, Mega Lug by EBAA Iron, JCM Industries Restraint System, Gripper by Romac, or equal, designed to withstand a minimum of 250 psi line pressures.

## 2.04 MISCELLANEOUS APPURTENANCES

- A. Valve boxes shall have cast iron top and lid, EJW 3663 or equal, minimum inside diameter of 10" with 8" PVC riser pipe as required. Cast iron lid shall be marked with a "W" cast into the lid.
- B. All non-metallic pipelines which are 2-inches or greater in diameter shall be installed with continuous 14 gauge insulated copper toning wire connected to all pipeline appurtenances to facilitate locating the pipe.
- C. Fire hydrants shall conform to the requirements of AWWA C-502, 8 inch dry barrel traffic model, with 5 ¼" main valve, one 4 ½" pumper nozzle and two 2" hose nozzles, with 6" MJ line connection. Hydrants shall be Mueller Super Centurion 200, Clow Medallion, M&H 929, Waterous Pacer 5 ¼", EJW Water Master or approved equal. A 5" storz adapter shall be installed on the 4 ½" pumper nozzle of each hydrant. Hydrants shall be painted with Miller Safety Orange paint or approved equal.

## 2.05 PRECAST CONCRETE STRUCTURES

- A. Unless otherwise noted on the Drawings precast structures shall be designed for an H-20 wheel load.
- B. Manholes shall conform to the requirements of ASTM C497/C497M. Manhole risers, cones and flat tops shall be precast. Minimum wall thickness shall be as shown in the drawings. Cones shall have the same wall thickness and reinforcement as 48-inch riser sections. Precast manhole bases and precast flat tops shall be used as required. All sanitary sewer manholes shall have integral, non-corrosive steps.
- C. Manhole frames and covers shall be cast iron conforming to the requirements of ASTM 105, Class 30B. Frames shall be Olympic Foundry, Inc. Model MH26 Suburban style (6-inch high) with two hole lids for sanitary sewers and 16 hole lids for storm drains, or equal, unless noted to be Standard style (10-inch high) on the Drawings.
- D. Catch basins shall be ODOT Type G-2, frames and grates shall conform to the requirements of ASTM 227/A663 grade 60, ASTM 270/A 709/A 36 or M103/A 27, grade 65-35 as shown on the plans.
- E. Mortar shall conform to the requirements of ASTM C 387, or be proportioned one part Portland Cement to two parts clean, well-graded sand which will pass a 1/8 inch screen.
- F. Non-shrink grout shall be Sika 212, Euco-S, Five-Star, or approved equal, non-metallic cementitious commercial grout exhibiting zero shrinkage per ASTM C-827 and CRD-C-621. Non-shrink grouts shall be placed or packed only with the use of an approved commercial concrete bonding agent applied to all cured concrete surfaces being grouted.
- G. Manhole steps shall be Copolymer Polypropylene Plastic conforming with ASTM C-478 with 1/2" grade 60 reinforcement bar conforming with ASTM A-615. Steps must be tight and firmly embedded.
- H. Manholes and Inlets shall comply with requirements of ODOT/APWA 2008 Standard Specifications for Construction, Sections 00470 and 002450.

## PART 3 - EXECUTION

### 3.01 INSTALLATION

- A. All material shall be installed in accordance with these specifications.
- B. All material shall be handled with care to avoid damage. Whether moved by hand, skid, or hoists, material shall not be dropped, bumped, or allowed to impact. The

CONTRACTOR shall provide safe storage for material until it has been incorporated into the completed project. The interior of all pipe, couplings, rings, fittings, and other accessories shall be kept free from dirt and other foreign matter at all times.

- C. All pipelines shall be laid to and maintained at lines and grades required by the plans.
- D. All manhole and catch basin frames and covers in paved areas shall be set flush with the road surface.
- E. All joints and connections in manholes shall be made completely water tight.
- F. All mortar joints between precast shall be thoroughly wetted, then completely filled with mortar.
- G. When catch basin laterals cross the new waterline, the new waterline shall be deflected under storm lateral. A minimum of six (6) inches of clearance shall be provided at the crossing point.

### 3.02 TESTING

- A. All gravity storm drain and sanitary sewer lines will be field inspected by the Engineer or the City. The contractor will be required to give a minimum of 24 hours advance notice.
- B. Fire hydrant relocation will be swab chlorinated and witnessed by Canby Utility inspector.

**\*\*END OF SECTION\*\***

*This Page Is Intentionally Left Blank*

**SECTION 02900  
LANDSCAPING**

**PART 1 - GENERAL**

1.01 DESCRIPTION

This section includes provisions for furnishing all labor, equipment, and material for the restoration or creation of landscaped areas as shown on the plans, or disturbed during the construction activities, including backfilling behind all curbs and sidewalks to match existing surroundings.

**PART 2 - PRODUCTS**

2.01 TOP SOIL

Top soil shall be light loam material free from sticks, rocks, clay, etc., excavated from the project site or of general quality available within 10 miles of the site or growing medium consisting of sand, loam and compost material, 3-way mix free from sticks, rocks, clay, etc.,

2.02 SOD AND SEED MIX FOR DISTURBED AREAS

- A. Sod shall be a dense ryegrass blend readily available for installation from local suppliers. Sod shall be used for restoration of all impacted lawn areas. Seed mix may be used for all other disturbed areas. Seed mix for disturbed areas shall be Hobbs & Hopkins PT-705 PDX Ecology Mix (phone 503-239-7518), or equal. Seeding rate: 50 lbs/acre.
- B. Fertilizer and weed killer shall be a commercially available type recommended for specific application.

2.03 BARK CHIPS

Bark chips shall be new hemlock product, maximum size 3/4".

**PART 3 - EXECUTION**

3.01 TOP SOIL

- A. All areas disturbed by the construction shall be reshaped, raked and landscaped to match the surrounding ground.
- B. Soil shall be compacted by tamping and/or rolling to stabilize prior to seeding or landscaping.



### 3.02 SOD AND SEED MIX FOR DISTURBED AREAS

- A. Ground to receive sod shall be tilled, raked and compacted, and then fertilized prior to placing sod. Sod strips must be laid immediately after delivery, kept watered for up to 2 weeks frequently enough to keep it moist at all times especially during hot and windy weathers. The contractor should coordinate with the local property owner to incorporate the new sod into the existing irrigation system coverage. Survival of the grass sod shall be a condition of the warranty.
- B. All disturbed areas shall receive ground cover in accordance with local, state or federal regulations. If healthy vegetation has not been established by November 1, sod or temporary bark groundcover will be required. Planting grass seed or sod may only be applied between June 1 to September 30 to assure proper growth (any seeding planned after September must be preapproved and use pre-germinated grass seed). All seeded areas shall be prepped, fertilized and have peat moss mulch applied. Grass seed mix application shall be applied based on the supplier's recommendations.
- C. Ground shall be prepared by tilling and raking to grade to remove all debris and rocks, and then compacted prior to placement of fertilizer and seed or sod. Fertilizer shall be applied at a coverage rate as recommended by the manufacturer.
- D. All work shall be of professional quality and acceptable to the OWNER and ENGINEER. CONTRACTOR shall be responsible for complete care of all disturbed areas, including mowing and watering if deemed necessary until acceptance of the project.

### 3.03 BARK CHIPS

- A. Bark chips shall be applied where required to match existing surfacing to provide a minimum uniform thickness of 2".

### 3.04 SPECIAL PRECAUTIONS TO PROTECT TREES

- A. All trees on the project site designated to remain shall be protected from damage by placing individual construction fencing around each tree prior to work in the area. Where excavation is inside the root ball areas, excavation shall be completed to protect any root over 2" diameter, if removal is necessary, it must be sawcut and excavation shall proceed by hand to avoid damage to the any roots.

**\*\* END OF SECTION \*\***

**PLAN DRAWINGS**

PLAN DRAWINGS

# CITY OF CANBY

# N MAPLE STREET IMPROVEMENTS

NE 10TH AVENUE TO NE 14TH AVENUE  
 CLACKAMAS COUNTY, OREGON  
 FEBRUARY 2019

PROJECT  
 LOCATION

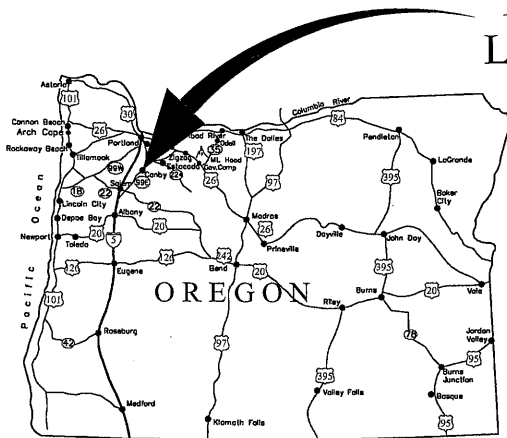

## CITY OF CANBY

HONORABLE BRIAN HODSON  
 TIM DALE  
 SHAWN VARWIG  
 TRACI HENSLEY  
 GREG PARKER  
 SARAH SPOON  
 TRACI HEIDT  
 RICK ROBINSON

MAYOR  
 COUNCIL PRESIDENT  
 COUNCIL MEMBER  
 COUNCIL MEMBER  
 COUNCIL MEMBER  
 COUNCIL MEMBER  
 CITY ADMINISTRATOR

## LEGEND

●	MONUMENTS FOUND TO BE PROTECTED	⊗	EXISTING FIRE HYDRANT
— SA —	EXISTING SEWER	CB □	EXISTING CATCH BASIN
— ST —	EXISTING STORM	⊙	EXISTING STORM MANHOLE
— W —	EXISTING WATER	CO ○	EXISTING CLEANOUT
— T —	EXISTING TELEPHONE	⊕	EXISTING SANITARY MANHOLE
— P —	EXISTING UNDERGROUND POWER	☆	EXISTING LIGHT POLE
— X —	EXISTING FENCE TO BE PROTECTED	⊗	EXISTING POWER POLE
— E —	EXISTING UNDERGROUND ELECTRIC	⊗	EXISTING WATER VALVE
— FO —	EXISTING UNDERGROUND FIBER OPTIC	WM □	EXISTING WATER METER
▨	EXISTING CONCRETE SIDEWALK	○	EXISTING TREE
▨	EXISTING GRAVEL SURFACE	MB □	EXISTING MAILBOX
▨	EXISTING ASPHALT CONCRETE	⊕	NEW CATCH BASIN
▨	EXISTING SIDEWALK TO BE REMOVED	⊙	NEW STORM MANHOLE
---	EXISTING AC TO GRAVEL	---	NEW STORM LINE
⊗	EXISTING TREES TO BE REMOVED	▨	NEW CONCRETE SIDEWALK
		▨	NEW ASPHALT CONCRETE

## SHEET INDEX

C1	COVER SHEET & INDEX
C2	EXISTING CONDITIONS
C3	N MAPLE ST. STA. 0+00 - 5+00, PLAN & PROFILE
C4	N MAPLE ST. STA. 5+00 - 10+00, PLAN & PROFILE
C5	N MAPLE ST. STA. 10+00 - 13+09, PLAN & PROFILE
C6	CONSTRUCTION DETAILS
C7	CONSTRUCTION DETAILS
C8	CONSTRUCTION DETAILS
C9	CONSTRUCTION DETAILS

**ALL UTILITY CROSSINGS ARE APPROXIMATE, CONTRACTOR TO POTHOLE AND FIELD DEPTH VERIFY PRIOR TO CONSTRUCTION AND CONSULT WITH THE ENGINEER REGARDING ANY CONFLICTS**

**CONTRACTOR TO PROTECT EXISTING POWER, TELEPHONE/TELECOMMUNICATION LINES & COORDINATE RELOCATION OF ANY LINES THAT ARE IN CONFLICT WITH THE CONSTRUCTION WITH APPROPRIATE AGENCY**

**CALL BEFORE YOU DIG**  
 ATTENTION: OREGON LAW REQUIRES YOU TO FOLLOW RULES ADOPTED BY THE OREGON UTILITY NOTIFICATION CENTER. THOSE RULES ARE SET FORTH IN OAR 952-001-0010 THROUGH OAR 952-001-0090. YOU MAY OBTAIN COPIES OF THESE RULES BY CALLING THE CENTER. (NOTE: THE TELEPHONE NUMBER FOR THE OREGON UTILITY NOTIFICATION CENTER IS (503) 232-1987 OR 811 OR 1-800-332-2344

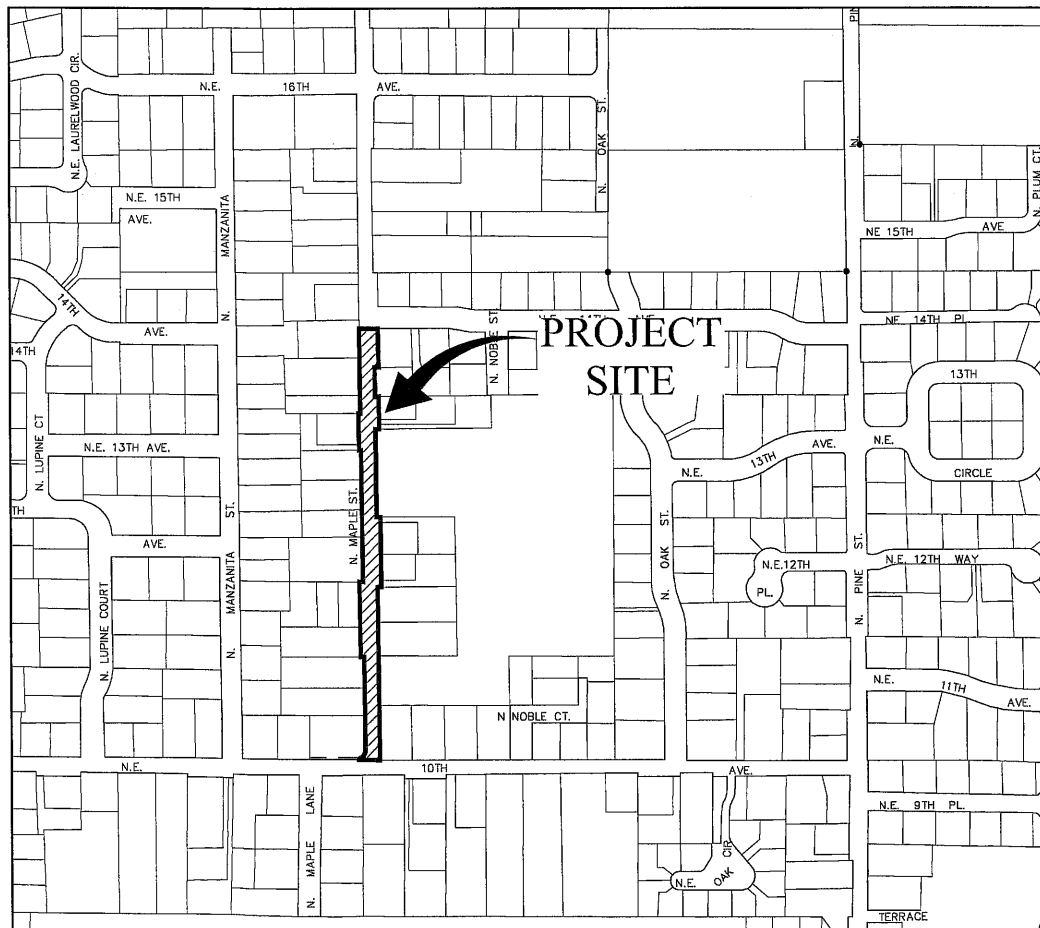

CITY OF CANBY

VICINITY MAP

NOT TO SCALE

GENERAL TOPOGRAPHIC SURVEY HAS BEEN PROVIDED BY ZTEC ENGINEERS, INC.

BAR IS ONE INCH ON ORIGINAL DRAWING.  
 ADJUST SCALE AS SHOWN ACCORDINGLY.

REV.	DESCRIPTION	REVISED BY	DATE

REVISIONS

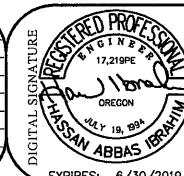

CURRAN-McLEOD, INC.  
 CONSULTING ENGINEERS  
 6655 S.W. HAMPTON ST., SUITE 210  
 PORTLAND, OREGON 97223  
 PHONE (503) 684-3478

CITY OF CANBY

COVER SHEET & INDEX

N. MAPLE STREET IMPROVEMENTS  
 CLACKAMAS COUNTY, OREGON

DATE	2/2019
P/N	1716
D/R	HAI
D/S	JHH
CAD#	1716-C1

C1  
 OF  
 9

J:\Canby\1716-N Maple St Improvements\DWG\1716-C1.dwg, 1/24/2019 11:36:08 AM, Kyocera TASKalfa 5501i KX(11x17).pc3

J:\Canby\1716 - N Maple St Improvements\DWG\1716-C2-EXISTING CONDITIONS.dwg, 1/24/2019 11:36:49 AM, Kyocera TASKalfa 5501i KX(11x17).pc3

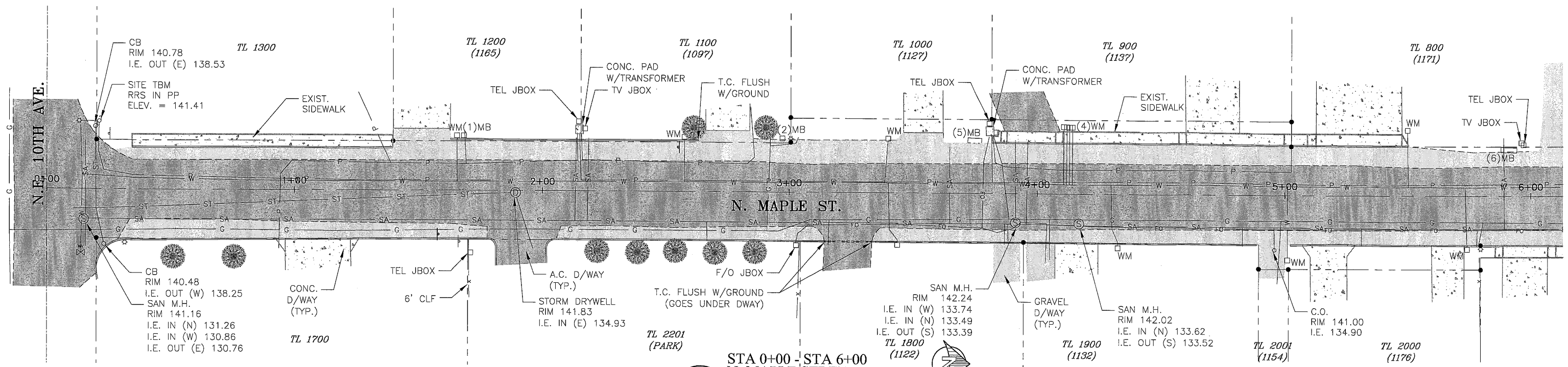

STA 0+00 - STA 6+00  
N. MAPLE STREET - PLAN  
SCALE: 1" = 20'

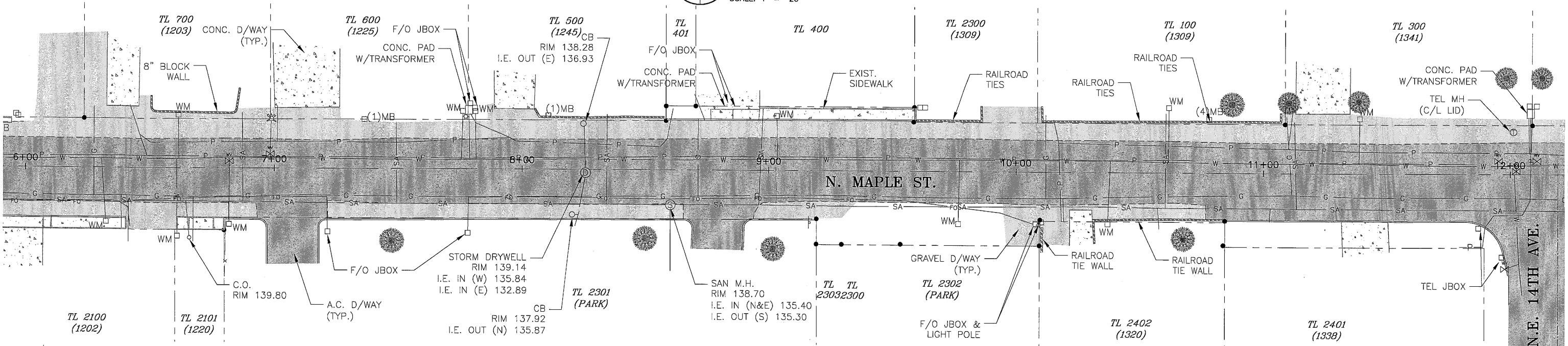

STA 6+00 - STA 12+00  
N. MAPLE STREET - PLAN  
SCALE: 1" = 20'

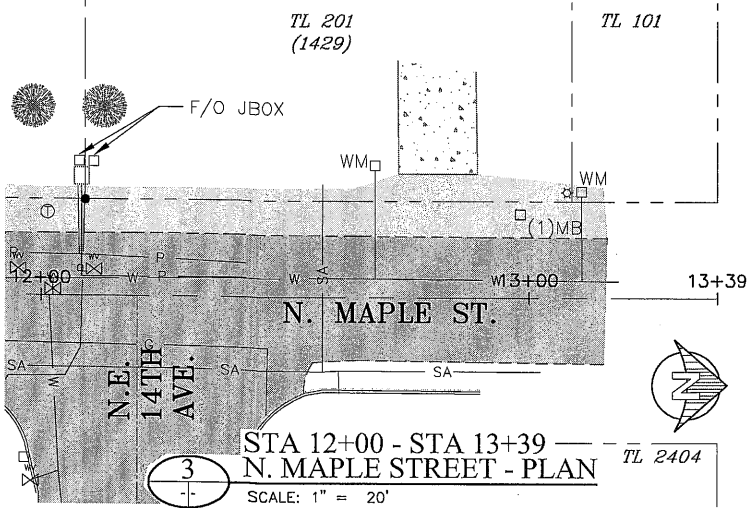

STA 12+00 - STA 13+39  
N. MAPLE STREET - PLAN  
SCALE: 1" = 20'

BAR IS ONE INCH ON ORIGINAL DRAWING.  
ADJUST SCALE AS SHOWN ACCORDINGLY.

REV.	DESCRIPTION	REVISED BY	DATE

REVISIONS

**CURRAN-McLEOD, INC.**  
CONSULTING ENGINEERS

6655 S.W. HAMPTON ST., SUITE 210  
PORTLAND, OREGON 97223  
PHONE (503) 684-3478

REGISTERED PROFESSIONAL ENGINEER  
17,219PE  
OREGON  
JULY 18, 1994  
SALMAN ABBAS IBRAHIM  
EXPIRES: 6/30/2019

CITY OF CANBY  
**N. MAPLE STREET**  
STA: 0+00 - 13+39  
EXISTING CONDITIONS  
N. MAPLE STREET IMPROVEMENTS  
CLACKAMAS COUNTY, OREGON

DATE	2/2019
P/N	1716
D/B	HAL
D/S	JHH
CDN	1716-C2

C2  
OF  
9



J:\Canby\1716 - N Maple St Improvements\DWG\1716-C3-C5.dwg, 1/25/2019 8:43:02 AM, Kycera TASKalfa 5501i KX(11x17).pc3

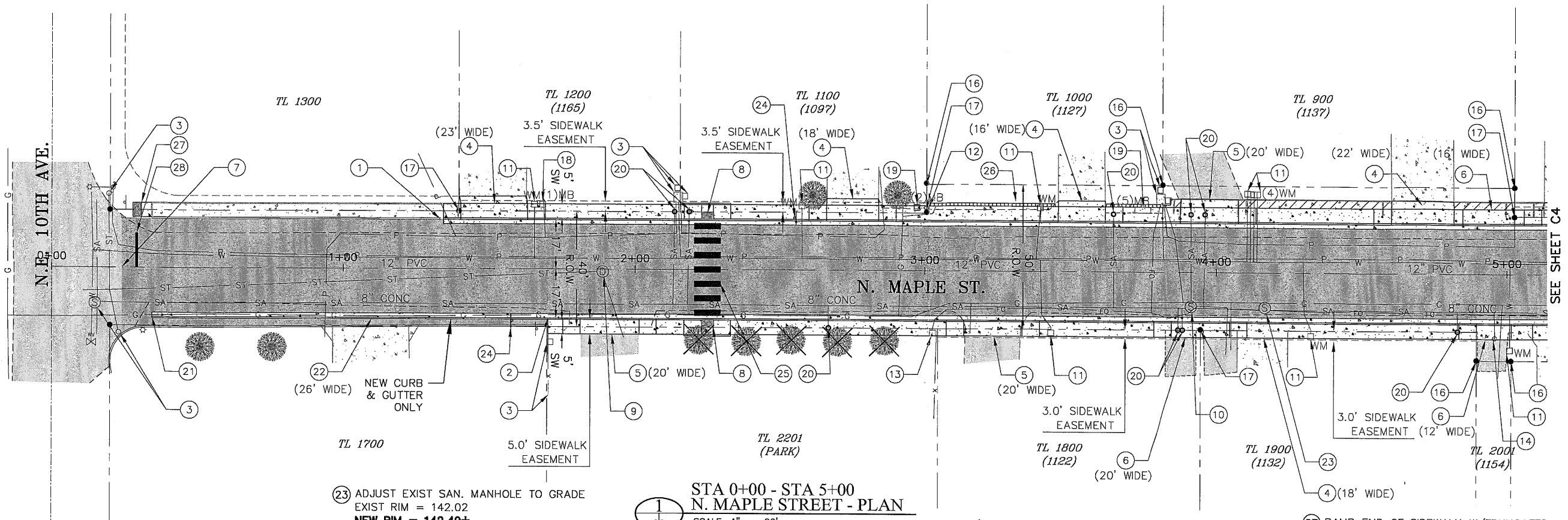

1 STA 0+00 - STA 5+00  
N. MAPLE STREET - PLAN

2 STA 0+00 - STA 5+00  
N. MAPLE STREET - PROFILE

22 CONSTRUCT 17' WIDE DRIVEWAY DEPRESSED CURB & GUTTER TO MATCH EXIST DRIVEWAY.

23 ADJUST EXIST SAN. MANHOLE TO GRADE  
EXIST RIM = 142.02  
NEW RIM = 142.49±

24 INSTALL PEDESTRIAN CROSSING SIGNS  
W11A-2, 30' MIN. AHEAD NEAREST  
BOTTOM OF RAMP.

1

SCALE: 1" = 20'

2

SCALE: 1" = 20'  
VERT: 1" = 2'



25 INSTALL CONTINENTAL CROSSWALK.

26 INSTALL RETAINING WALL, SEE SHEET C7 FOR DETAILS.

27 RAMP END OF SIDEWALK W/TRUNCATED DOME MAT.

28 12" WIDE STOP BAR

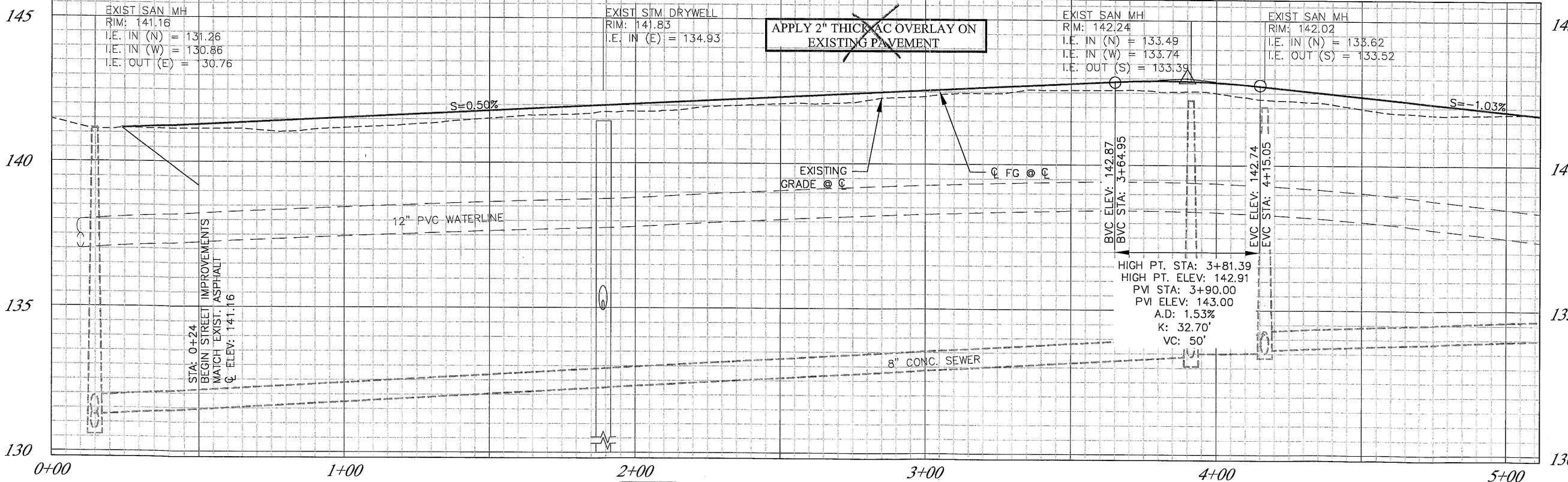

- CONSTRUCTION NOTES:**
- 1 STA: 1+33.37 17' LT  
BEGIN NEW CURB & GUTTER AND SIDEWALK,  
MATCH EXIST.
  - 2 STA: 1+70.00 17' RT  
BEGIN NEW CURB & GUTTER AND SIDEWALK.
  - 3 PROTECT EXIST POWER POLE, PEDESTALS,  
VAULTS, MANHOLES, FENCES, CATCH BASINS,  
FIRE HYDRANT.
  - 4 CONSTRUCT CONCRETE RESIDENTIAL DRIVEWAY  
APPROACH & MATCH EXIST CONCRETE  
SURFACE. SEE DETAILS.
  - 5 CONSTRUCT CONCRETE RESIDENTIAL DRIVEWAY  
APPROACH & MATCH EXIST ASPHALT  
SURFACE. SEE DETAILS.
  - 6 CONSTRUCT CONCRETE RESIDENTIAL DRIVEWAY  
APPROACH & MATCH EXIST GRAVEL SURFACE.  
SEE DETAILS.
  - 7 STA: 0+24  
BEGIN STREET IMPROVEMENTS, SAWCUT &  
MATCH EXIST ASPHALT.
  - 8 CONSTRUCT NEW ADA OR MIDBLOCK ADA  
CROSSING, SEE DETAILS.
  - 9 ADJUST EXIST STORM DRYWELL TO GRADE  
EXIST RIM = 141.83  
NEW RIM = 141.97±
  - 10 ADJUST EXIST SAN. MANHOLE TO GRADE  
EXIST RIM = 142.24  
NEW RIM = 142.66±
  - 11 WATER METER BOXES TO BE ADJUSTED TO  
SIDEWALK GRADE BY CANBY UTILITY,  
CONTRACTOR TO COORDINATE ALL EFFORTS.
  - 12 MAINTAIN A MIN. OF 48" PEDESTRIAN PATH  
FROM ANY OBSTRUCTIONS.
  - 13 RELOCATE EXIST FIBER OPTIC, POWER POLE  
PEDESTALS. CONTRACTOR TO COORDINATE ALL  
EFFORTS WITH THE PROPER FRANCHISE  
UTILITY.
  - 14 ADJUST EXIST CLEAN OUT TO GRADE.  
EXIST. RIM = 141.00  
NEW RIM = 141.67±
  - 15 DEMO EXIST CURB, SIDEWALK, DRIVEWAY,  
TREES, SHRUBS & FENCES WITHIN OUTLINED  
PROJECT LIMITS.
  - 16 PROPERTY CORNER MONUMENTS TO BE  
PROTECTED DURING CONSTRUCTION.
  - 17 ALL DISTURBED PROPERTY CORNERS WITHIN  
THE PROJECT LIMITS SHALL BE RESET.
  - 18 RELOCATE EXIST SINGLE MAILBOX & PAPER  
BOX ON NEW SUPPORT PER DETAIL.
  - 19 RELOCATE EXIST MULTIPLE MAIL BOXES &  
PAPER BOXES PER DETAIL.
  - 20 EXPOSE EXIST SANITARY SEWER LATERAL AND  
INSTALL A CLEAN OUT 3' FROM FACE OF  
CURB SEE DETAIL.
  - 21 STA: 0+34  
BEGIN NEW CURB & GUTTER 17' RT.

BAR IS ONE INCH ON ORIGINAL DRAWING.  
ADJUST SCALE AS SHOWN ACCORDINGLY.

REV.	DESCRIPTION	REVISED BY	DATE

REVISIONS

CURRAN-McLEOD, INC.  
CONSULTING ENGINEERS

6655 S.W. HAMPTON ST., SUITE 210  
PORTLAND, OREGON 97223  
PHONE (503) 684-3478

DIGITAL SIGNATURE  
KASSAN ABBAS TERPANH  
EXPIRES: 6/30/2019

CITY OF CANBY

N. MAPLE STREET  
STA: 0+00 - 5+00  
PLAN & PROFILE  
N. MAPLE STREET IMPROVEMENTS  
CLACKAMAS COUNTY, OREGON

DATE	2/2019
P/N	1716
D/R	HAI
D/S	JHH
D/M	1716-C3

C3 OF 9

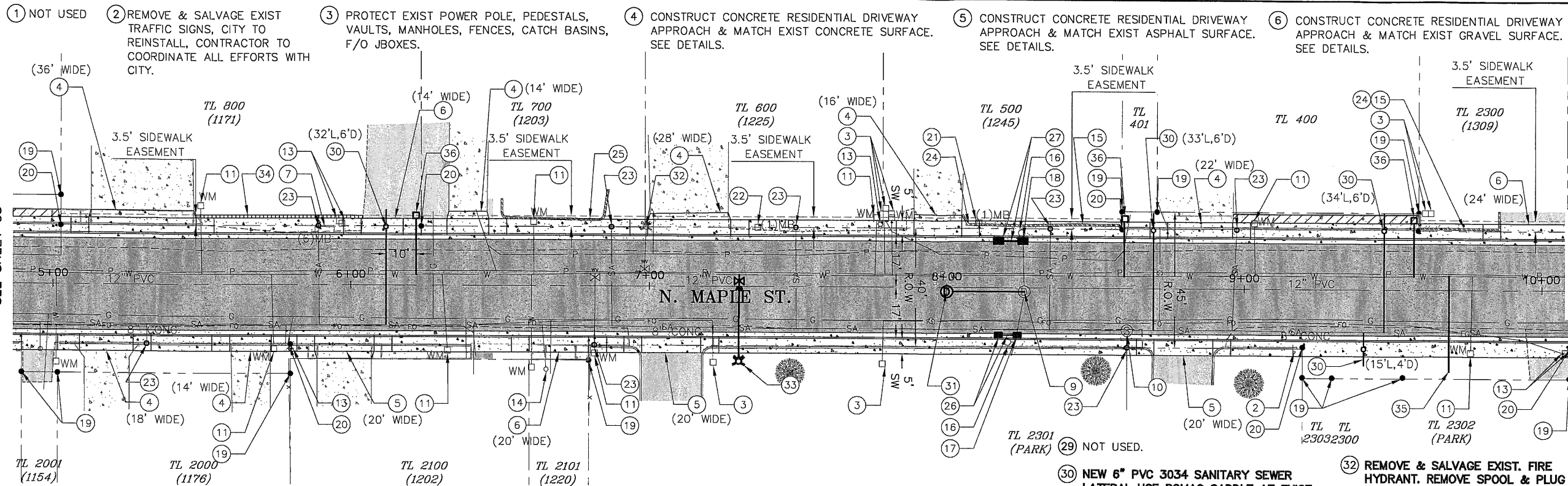

26) STA: 8+17.30, 17' RT  
 CONSTRUCT NEW WAITE CATCH BASIN  
 (SEE DETAIL 4 SHEET C6)  
 RIM ELEV: 138.45  
 I.E. OUT: 135.52  
 4 LF 10" PVC C900 S=0.50%

27) STA: 8+17.30, 17' LT  
 CONSTRUCT NEW TYPE G2 CATCH BASIN  
 RIM ELEV: 138.45  
 I.E. OUT: 136.75  
 5 LF 10" PVC C900 S=0.50%

28) NOT USED

29) NOT USED.

30) NEW 6" PVC 3034 SANITARY SEWER LATERAL USE ROMAC SADDLE AT EXIST. 8" CONC. PIPE.

31) STA: 8+00, 1.35' RT  
 CONSTRUCT NEW 48" DIA. DRYWELL  
 RIM = 138.97  
 I.E. IN: 132.56  
 SUMP: 112.80

32) REMOVE & SALVAGE EXIST. FIRE HYDRANT. REMOVE SPOOL & PLUG WITH BLIND FLANGE AT VALVE.

33) STA: 7+30  
 HOT TAP EXIST 12" PVC USING:  
 12" X 6" FLANGE TEE  
 6" FL X MJ GATE VALVE  
 6" SPOOL, RESTRAIN ALL JOINTS.  
 INSTALL EXIST HYDRANT FROM NOTE 32

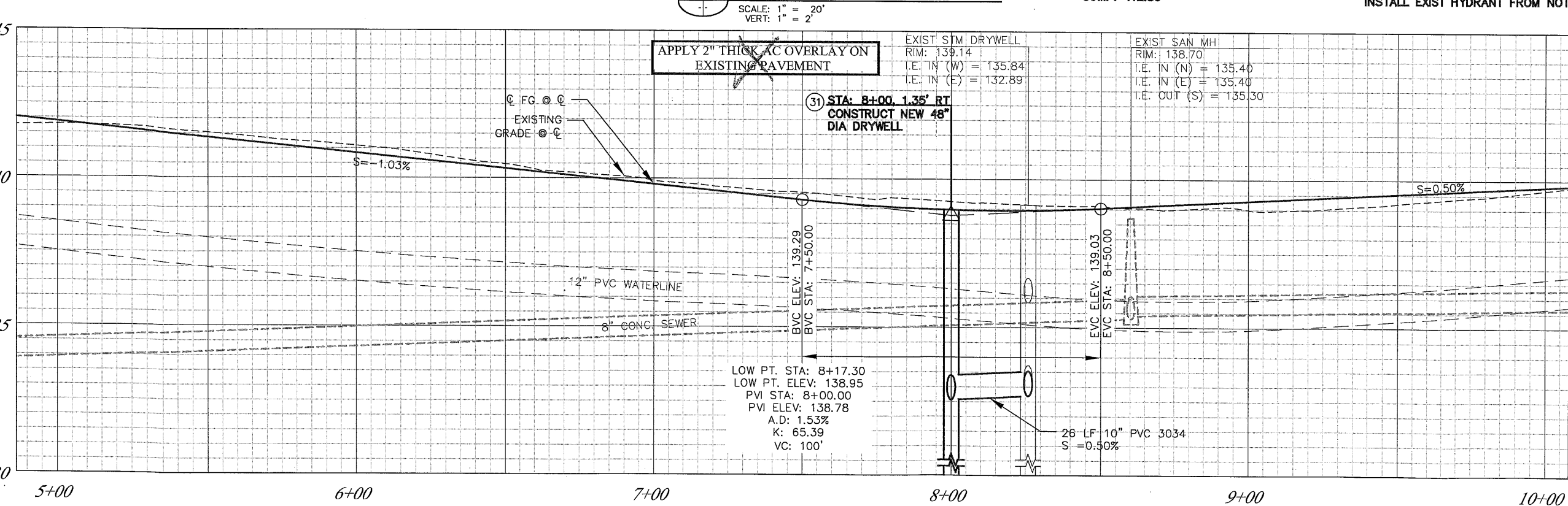

34) INSTALL RETAINING WALL, SEE SHEET C7 FOR DETAILS

35) NEW 1 1/2" WATER SERVICE.

36) NEW 1" WATER SERVICE.

APPLY 2" THICK AC OVERLAY ON EXISTING PAVEMENT

EXIST STM DRYWELL  
 RIM: 139.14  
 I.E. IN (W) = 135.84  
 I.E. IN (E) = 132.89

EXIST SAN MH  
 RIM: 138.70  
 I.E. IN (N) = 135.40  
 I.E. IN (E) = 135.40  
 I.E. OUT (S) = 135.30

31) STA: 8+00, 1.35' RT  
 CONSTRUCT NEW 48" DIA DRYWELL

LOW PT. STA: 8+17.30  
 LOW PT. ELEV: 138.95  
 PVI STA: 8+00.00  
 PVI ELEV: 138.78  
 A.D: 1.53%  
 K: 65.39  
 VC: 100'

26 LF 10" PVC 3034  
 S = 0.50%

- CONSTRUCTION NOTES:
- 7) RELOCATE EXIST MULTIPLE MAIL BOXES & PAPER BOXES PER DETAIL.
  - 8) NOT USED.
  - 9) ADJUST EXIST STORM DRYWELL TO GRADE. EXIST RIM = 139.14. NEW RIM = 138.92±. I.E. IN (E) = 132.89. I.E. IN (W) = 135.84. NEW I.E. OUT (S) = 132.69.
  - 10) ADJUST EXIST SAN. MANHOLE TO GRADE. EXIST RIM = 138.70. NEW RIM = 138.79±.
  - 11) WATER METER BOXES TO BE ADJUSTED TO SIDEWALK GRADE BY CANBY UTILITY, CONTRACTOR TO COORDINATE ALL EFFORTS.
  - 12) MAINTAIN A MIN. OF 48" PEDESTRIAN PATH FROM ANY OBSTRUCTIONS.
  - 13) RELOCATE EXIST FIBER OPTIC, POWER POLE PEDESTALS. CONTRACTOR TO COORDINATE ALL EFFORTS WITH THE PROPER FRANCHISE UTILITY.
  - 14) ADJUST EXIST CLEAN OUT TO GRADE. EXIST. RIM = 139.80. NEW RIM = 139.92±.
  - 15) DEMO EXIST CURB, SIDEWALK, DRIVEWAY, TREES, SHRUBS & FENCES WITHIN OUTLINED PROJECT LIMITS.
  - 16) REMOVE EXIST CATCH BASIN.
  - 17) CONSTRUCT NEW WAITE CATCH BASIN OVER EXIST PIPE (SEE DETAIL 4 SHEET C6). STA: 8+23, 17' RT. RIM: 138.45. I.E. IN: 135.34. I.E. OUT: 135.14.
  - 18) CONSTRUCT NEW TYPE G2 CATCH BASIN OVER EXIST PIPE. STA: 8+25, 17' LT. RIM: 138.45. I.E. IN: 136.95. I.E. OUT: 136.75.
  - 19) PROPERTY CORNER MONUMENTS TO BE PROTECTED DURING CONSTRUCTION.
  - 20) ALL DISTURBED PROPERTY CORNERS WITHIN THE PROJECT LIMITS SHALL BE RESET.
  - 21) RELOCATE EXIST SINGLE MAILBOX & PAPER BOX ON NEW SUPPORT PER DETAIL.
  - 22) RELOCATE EXIST SINGLE DECORATIVE MAILBOX AND SUPPORT, PER DETAIL.
  - 23) EXPOSE EXIST SANITARY SEWER LATERAL AND INSTALL A CLEAN OUT 3' FROM FACE OF CURB SEE DETAIL.
  - 24) CONTRACTOR TO REMOVE EXIST FENCE/RETAINING WALL UP TO 1' BEHIND BACK SIDEWALK.
  - 25) MEANDER SIDEWALK AROUND EXIST WALL, MAINTAIN 48" MIN CLEAR PATH.

J:\Canby\1716 - N Maple St Improvements\DWG\1716-C3-C5.dwg, 1/25/2019 8:41:26 AM, Kycera TASKalfa 5501i KX(11x17).pc3

BAR IS ONE INCH ON ORIGINAL DRAWING.  
 ADJUST SCALE AS SHOWN ACCORDINGLY.

REVISIONS

CURRAN-McLEOD, INC.  
 CONSULTING ENGINEERS  
 6655 S.W. HAMPTON ST., SUITE 210  
 PORTLAND, OREGON 97223  
 PHONE (503) 684-3478

CITY OF CANBY  
 N. MAPLE STREET  
 PLAN & PROFILE  
 STA: 5+00 - 10+00  
 N. MAPLE STREET IMPROVEMENTS  
 CLACKAMAS COUNTY, OREGON

DATE: 2/2019  
 P/N: 1716  
 D/R: HAI  
 D/S: JHH  
 CMT: 1716-C4

C4  
 OF  
 9

- CONSTRUCTION NOTES:**
- ① NOT USED.
  - ② NOT USED.
  - ③ PROTECT EXIST POWER POLE, PEDESTALS, VAULTS, MANHOLES, FENCES, CATCH BASINS, FIRE HYDRANT.
  - ④ CONSTRUCT CONCRETE RESIDENTIAL DRIVEWAY APPROACH & MATCH EXIST CONCRETE SURFACE. SEE DETAILS.
  - ⑤ CONSTRUCT CONCRETE RESIDENTIAL DRIVEWAY APPROACH & MATCH EXIST ASPHALT SURFACE. SEE DETAILS.
  - ⑥ CONSTRUCT CONCRETE RESIDENTIAL DRIVEWAY APPROACH & MATCH EXIST GRAVEL SURFACE. SEE DETAILS.
  - ⑦ END CURB & GUTTER & MATCH EXIST.
  - ⑧ CONSTRUCT NEW ADA OR MIDBLOCK ADA CROSSING, SEE DETAILS.
  - ⑨ INSTALL RETAINING WALL, SEE SHEET C7 FOR DETAILS.
  - ⑩ ALL DISTURBED PROPERTY CORNERS WITHIN THE PROJECT LIMITS SHALL BE RESET.
  - ⑪ WATER METER BOXES TO BE ADJUSTED TO SIDEWALK GRADE BY CANBY UTILITY, CONTRACTOR TO COORDINATE ALL EFFORTS.
  - ⑫ MAINTAIN A MIN. OF 48" PEDESTRIAN PATH FROM ANY OBSTRUCTIONS.
  - ⑬ RELOCATE EXIST FIBER OPTIC, POWER POLE PEDESTALS. CONTRACTOR TO COORDINATE ALL EFFORTS WITH THE PROPER FRANCHISE UTILITY.
  - ⑭ NOT USED.
  - ⑮ DEMO EXIST CURB, SIDEWALK, DRIVEWAY, TREES, SHRUBS & FENCES WITHIN OUTLINED PROJECT LIMITS.
  - ⑯ EXPOSE EXIST SANITARY SEWER LATERAL AND INSTALL A CLEAN OUT 3' FROM FACE OF CURB SEE DETAIL
  - ⑰ RELOCATE EXIST SINGLE MAILBOX & PAPER BOX ON NEW SUPPORT PER DETAIL.
  - ⑱ RELOCATE EXIST MULTIPLE MAIL BOXES & PAPER BOXES PER DETAIL.
  - ⑲ CONTRACTOR TO REMOVE, SALVAGE & RELOCATE EXIST FENCE/RETAINING WALL BEHIND BACK SIDEWALK.
  - ⑳ STA: 12+53  
END FULL STREET IMPROVEMENT  
BEGIN HALF STREET IMPROVEMENTS.
  - ㉑ STA: 13+09  
END STREET IMPROVEMENTS  
SAWCUT EXIST AC AND MATCH.
  - ㉒ MEANDER CURB & SIDEWALK AROUND EXIST TELEPHONE MANHOLE, ALLOW 48" MINIMUM PEDESTRIAN PATH.  
**EXIST RIM ELEV: 142.46**  
**PROJECTED RIM ELEV: 142.49**
  - ㉓ INSTALL CONTINENTAL CROSSWALK.

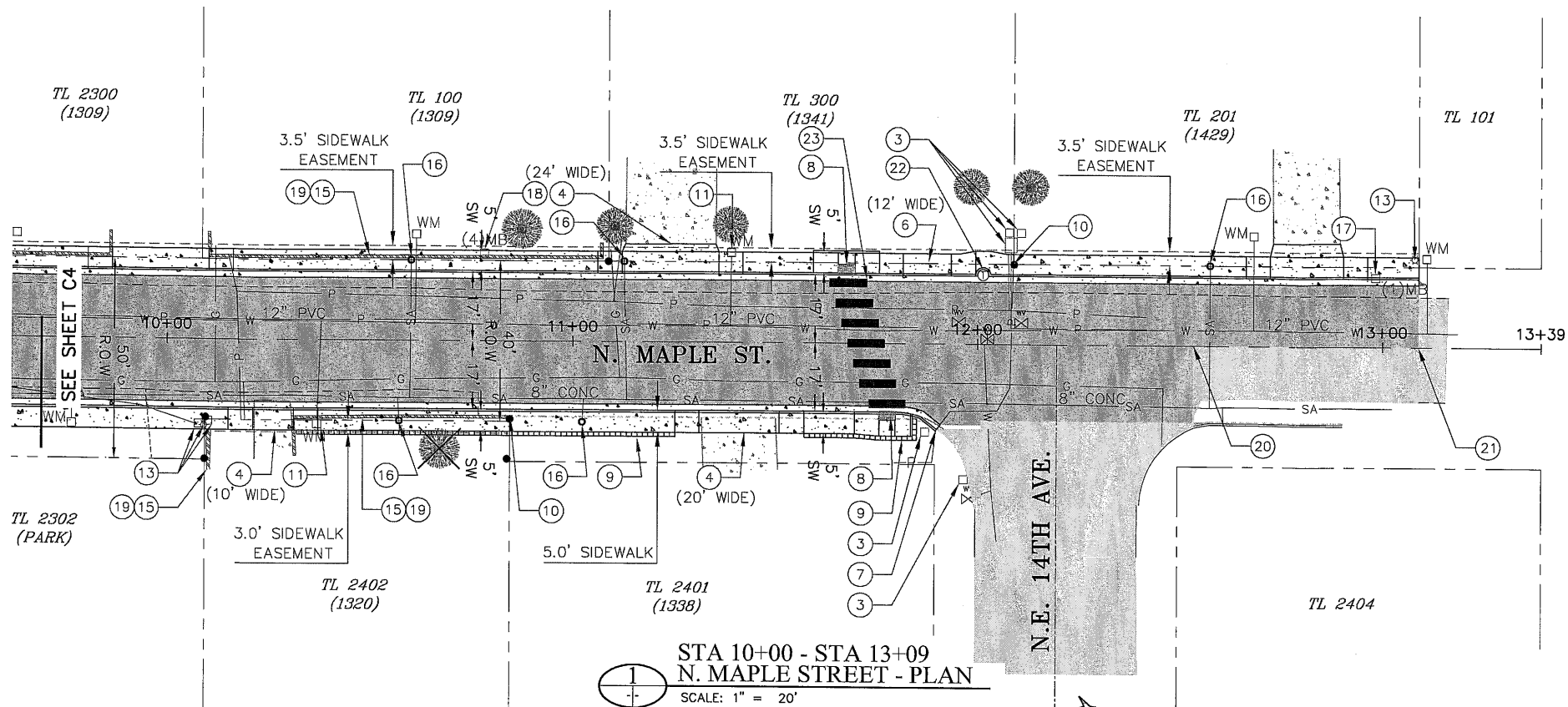

① STA 10+00 - STA 13+09  
N. MAPLE STREET - PLAN  
SCALE: 1" = 20'

② STA 10+00 - STA 13+09  
N. MAPLE STREET - PROFILE  
SCALE: 1" = 20'  
VERT: 1" = 2'

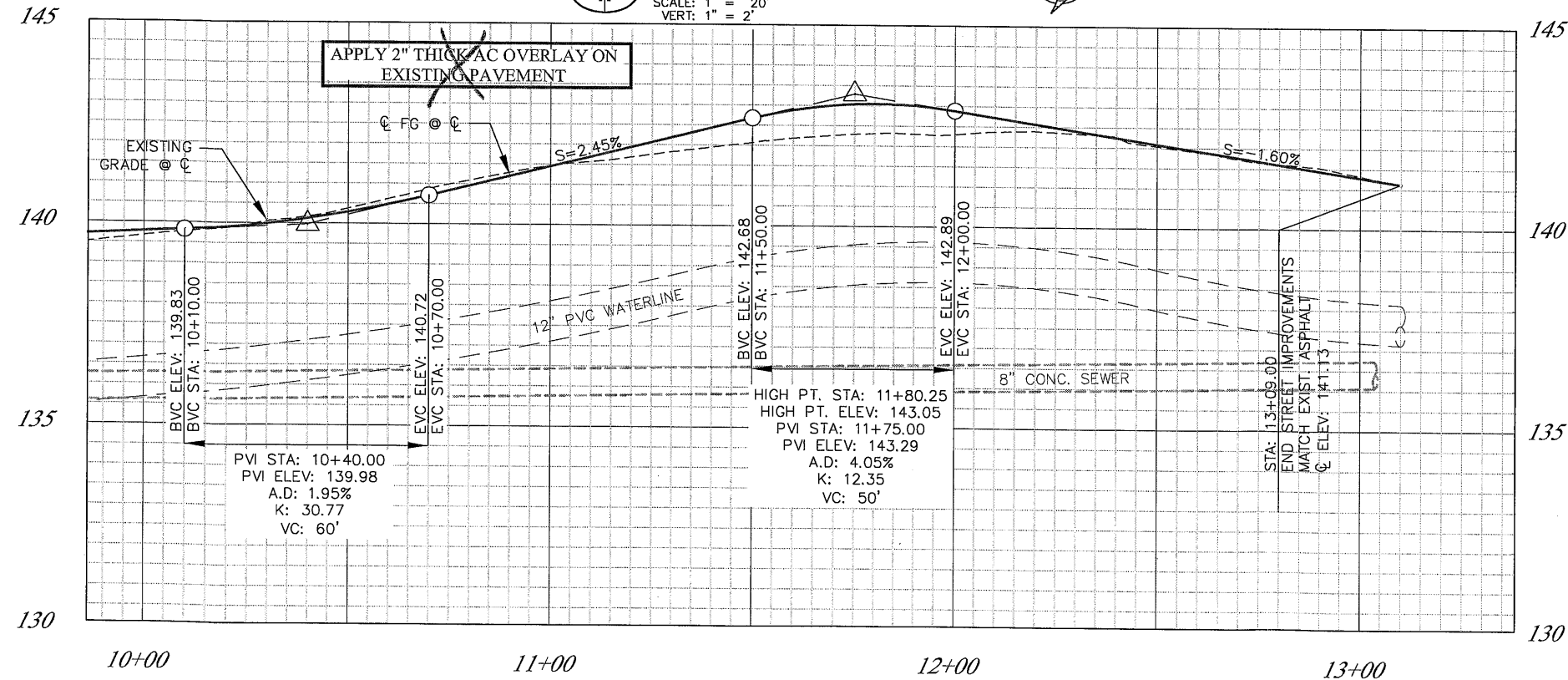

BAR IS ONE INCH ON ORIGINAL DRAWING.  
ADJUST SCALE AS SHOWN ACCORDINGLY.

REV.	DESCRIPTION	REVISED BY	DATE

REVISIONS

**CURRAN-McLEOD, INC.**  
CONSULTING ENGINEERS

6655 S.W. HAMPTON ST., SUITE 210  
PORTLAND, OREGON 97223  
PHONE (503) 684-3478

CITY OF CANBY  
**N. MAPLE STREET**  
**STA: 10+00 - 13+09**  
**PLAN & PROFILE**  
N. MAPLE STREET IMPROVEMENTS  
CLACKAMAS COUNTY, OREGON

DATE	2/2019
D/W	1716
D/B	HAI
D/S	JHH
CAD	1716-C5

**C5**  
**OF**  
**9**

J:\Canby\1716 - N Maple St Improvements\DWG\1716-C3-C5.dwg, 1/25/2019 8:42:42 AM, Kyocera TASKalfa 5501i KX(11x17).pc3



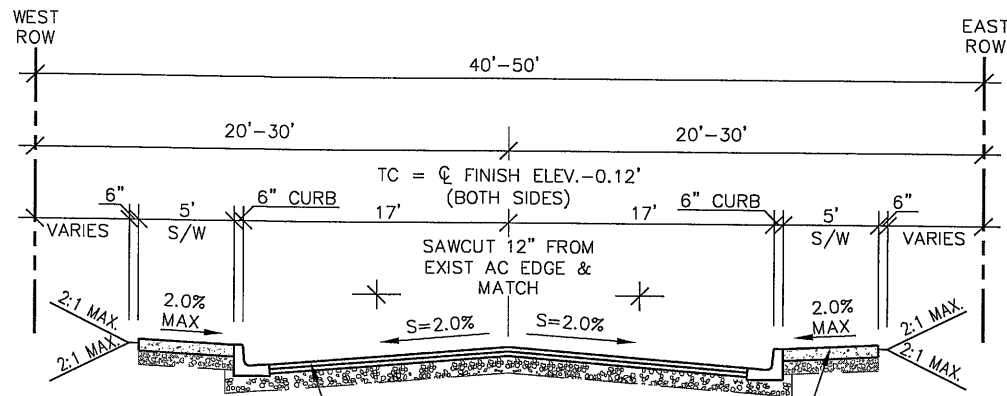

1 NORTH MAPLE STREET SECTION  
NOT TO SCALE

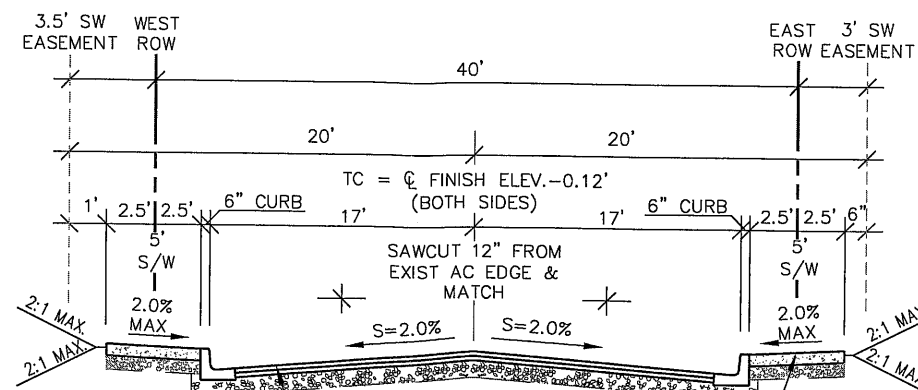

2 NORTH MAPLE STREET SECTION  
NOT TO SCALE



W11A-2

3 PEDESTRIAN CROSSING SIGN  
N.T.S.

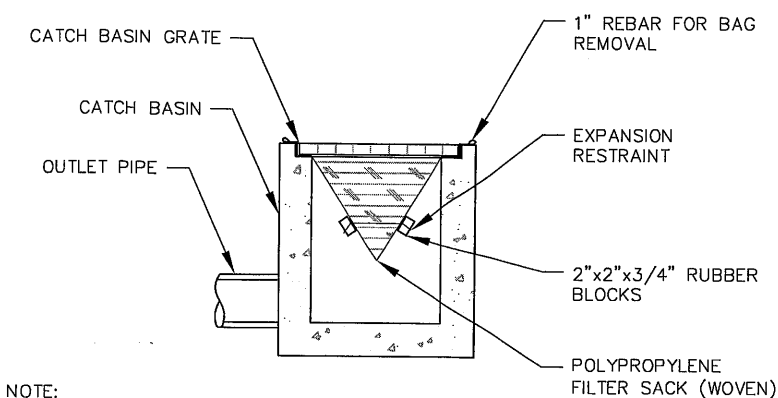

NOTE:

RECESSED CURB INLETS MUST BE BLOCKED WHEN USING FILTER FABRIC INLET SACKS. SIZE OF FILTER FABRIC INLET SACKS TO BE DETERMINED BY MANUFACTURE

4 WOVEN POLYPROPYLENE SACK - DETAIL  
N.T.S.

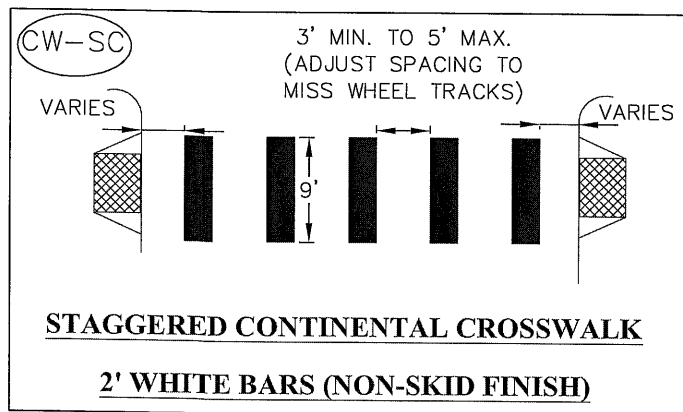

5 STAGGERED CONTINENTAL CROSSWALK  
(TWO FOOT WHITE BARS)  
SCALE: NTS



6 STOP BAR  
N.T.S.

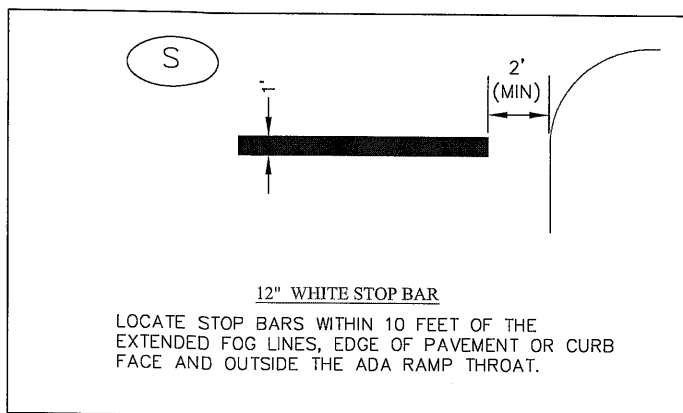

6 STOP BAR  
N.T.S.

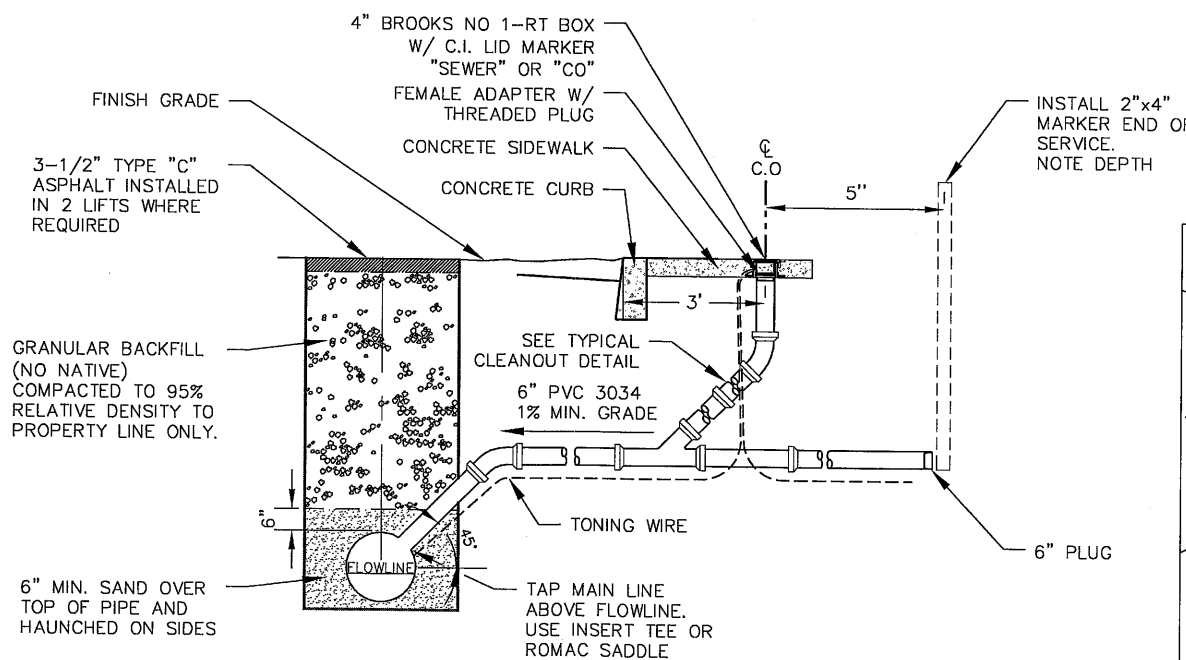

NOTES:

1. WASHED FILL SAND SHALL BE USED TO BED PIPE ON LATERAL SERVICE AND MUST HAVE 6" MIN. COVER AT LEAST TO THE PROPERTY LINE.
2. GRANULAR BACKFILL WILL BE NO LARGER THAN 1"-0" TO THE PROPERTY LINE. PEA ROCK WILL NOT BE ALLOWED UNLESS APPROVED BY THE CITY.
3. A TRACE WILL OF 18AWG. WILL BE SECURED AT THE MAIN LINE RUNNING UP TO THE CLEANOUT AT GROUND LEVEL, THEN BACK DOWN TO LATERAL SERVICE LINE, THE TO CLEANOUT AT THE FOUNDATION OF STRUCTURE.
4. 36" MIN. DEPTH IS REQUIRED UNLESS OTHERWISE APPROVED BY THE CITY.

7 TYPICAL SANITARY SEWER SERVICE  
N.T.S.

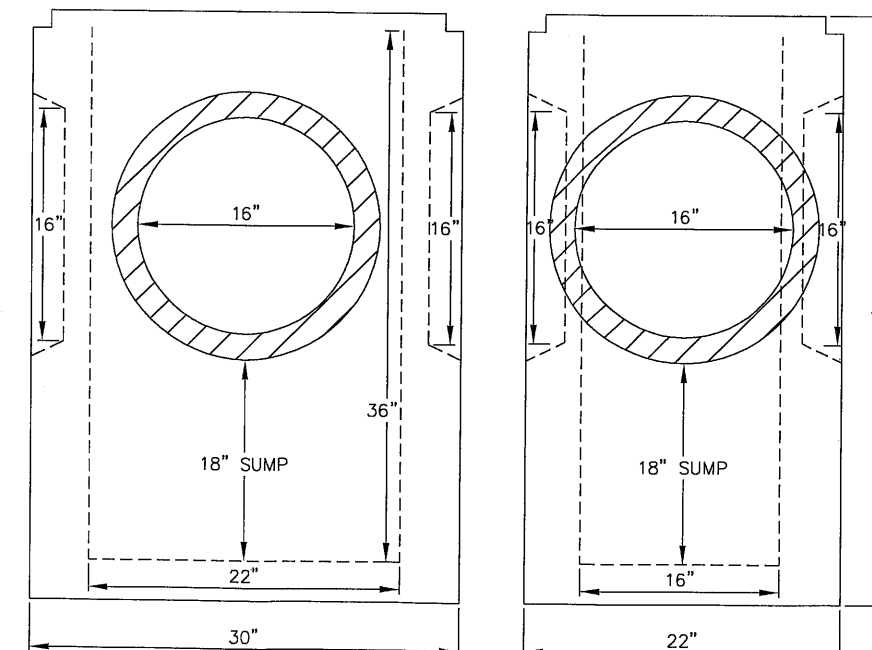

FRONT VIEW

SIDE VIEW

8 WAITE CATCH BASIN  
N.T.S.

BAR IS ONE INCH ON ORIGINAL DRAWING.  
ADJUST SCALE AS SHOWN ACCORDINGLY.

REV.	DESCRIPTION	REVISED BY	DATE

REVISIONS

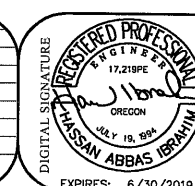

CURRAN-McLEOD, INC.  
CONSULTING ENGINEERS  
6655 S.W. HAMPTON ST., SUITE 210  
PORTLAND, OREGON 97223  
PHONE (503) 684-3478

CITY OF CANBY  
CONSTRUCTION DETAILS  
N. MAPLE STREET IMPROVEMENTS  
CLACKAMAS COUNTY, OREGON

DATE	2/2019
D/N	1716
D/B	HAI
D/S	JVB
CAD	1716-C6

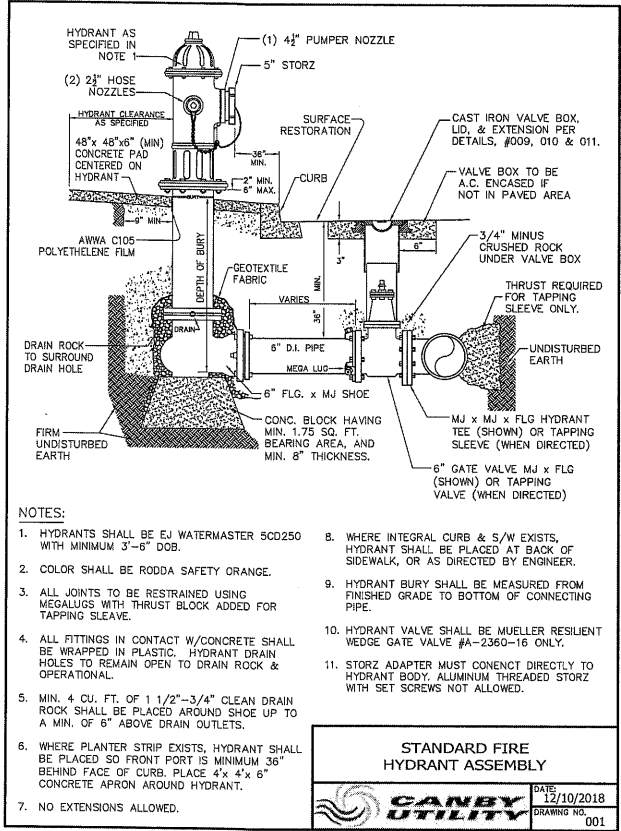

- NOTES:**
- HYDRANTS SHALL BE EJ WATERMASTER 50D250 WITH MINIMUM 3'-6" DOB.
  - COLOR SHALL BE RODDA SAFETY ORANGE.
  - ALL JOINTS TO BE RESTRAINED USING MEGALUGS WITH THRUST BLOCK ADDED FOR TAPPING SLEEVE.
  - ALL FITTINGS IN CONTACT W/CONCRETE SHALL BE WRAPPED IN PLASTIC. HYDRANT DRAIN HOLES TO REMAIN OPEN TO DRAIN ROCK & OPERATIONAL.
  - MIN. 4 CU. FT. OF 1 1/2"-3/4" CLEAN DRAIN ROCK SHALL BE PLACED AROUND SHOULDER UP TO A MIN. OF 6" ABOVE DRAIN OUTLETS.
  - WHERE PLANTER STRIP EXISTS, HYDRANT SHALL BE PLACED SO FRONT PORT IS MINIMUM 36" BEHIND FACE OF CURB. PLACE 4" x 4" x 6" CONCRETE APRON AROUND HYDRANT.
  - NO EXTENSIONS ALLOWED.
  - WHERE INTEGRAL CURB & S/W EXISTS, HYDRANT SHALL BE PLACED AT BACK OF SIDEWALK, OR AS DIRECTED BY ENGINEER.
  - HYDRANT BURY SHALL BE MEASURED FROM FINISHED GRADE TO BOTTOM OF CONNECTING PIPE.
  - HYDRANT VALVE SHALL BE MUELLER RESILIENT WEDGE GATE VALVE #A-2360-16 ONLY.
  - STORZ ADAPTER MUST CONNECT DIRECTLY TO HYDRANT BODY. ALUMINUM THREADED STORZ WITH SET SCREWS NOT ALLOWED.

**STANDARD FIRE HYDRANT ASSEMBLY**

DATE: 12/10/2018  
DRAWING NO: 001

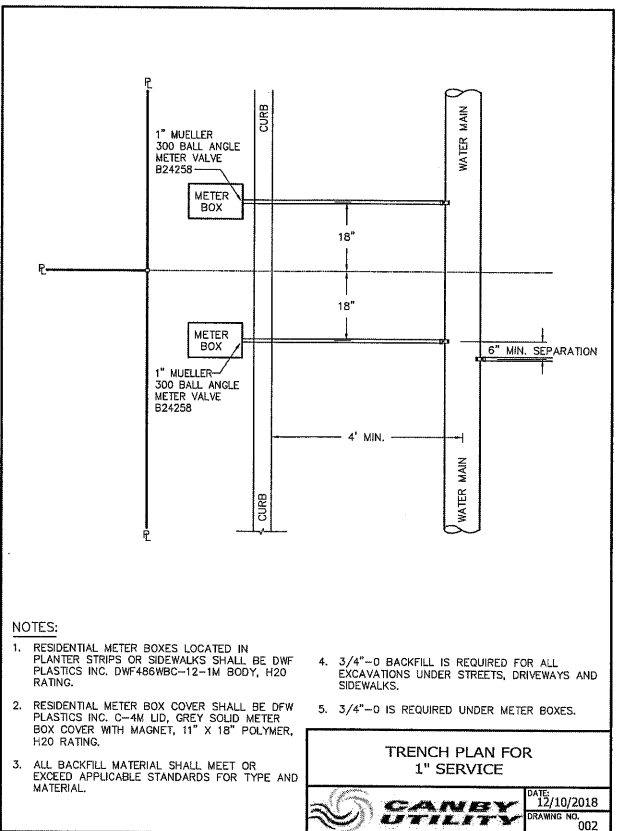

- NOTES:**
- RESIDENTIAL METER BOXES LOCATED IN PLANTER STRIPS OR SIDEWALKS SHALL BE DWF PLASTICS INC. DWF486WBC-12-1M BODY, H20 RATING.
  - RESIDENTIAL METER BOX COVER SHALL BE DWF PLASTICS INC. C-4M LID, GREY SOLID METER BOX COVER WITH MAGNET, 11" x 18" POLYMER, H20 RATING.
  - ALL BACKFILL MATERIAL SHALL MEET OR EXCEED APPLICABLE STANDARDS FOR TYPE AND MATERIAL.
  - 3/4"-0 BACKFILL IS REQUIRED FOR ALL EXCAVATIONS UNDER STREETS, DRIVEWAYS AND SIDEWALKS.
  - 3/4"-0 IS REQUIRED UNDER METER BOXES.

**TRENCH PLAN FOR 1" SERVICE**

DATE: 12/10/2018  
DRAWING NO: 002

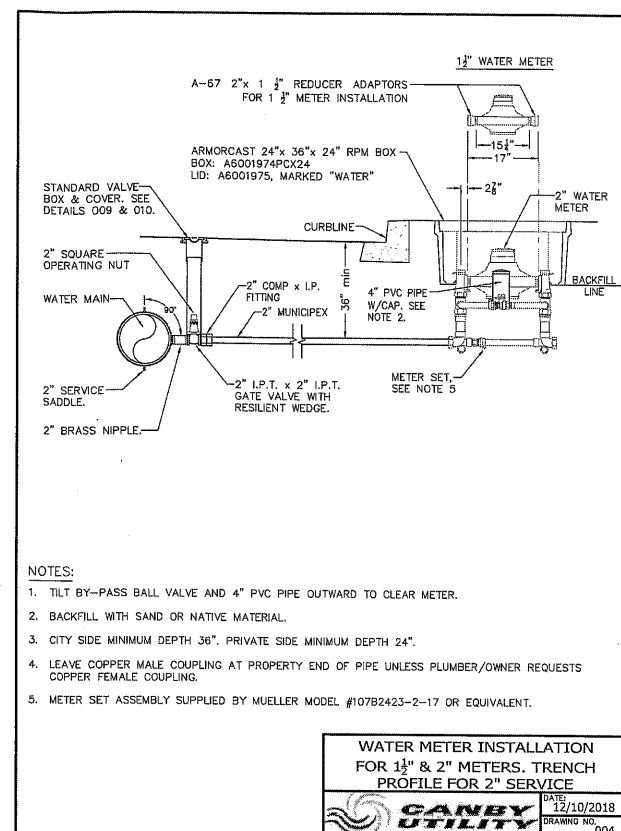

- NOTES:**
- TILT BY-PASS BALL VALVE AND 4" PVC PIPE OUTWARD TO CLEAR METER.
  - BACKFILL WITH SAND OR NATIVE MATERIAL.
  - CITY SIDE MINIMUM DEPTH 36". PRIVATE SIDE MINIMUM DEPTH 24".
  - LEAVE COPPER MALE COUPLING AT PROPERTY END OF PIPE UNLESS PLUMBER/OWNER REQUESTS COPPER FEMALE COUPLING.
  - METER SET ASSEMBLY SUPPLIED BY MUELLER MODEL #107B2423-2-17 OR EQUIVALENT.

**WATER METER INSTALLATION FOR 1 1/2" & 2" METERS. TRENCH PROFILE FOR 2" SERVICE**

DATE: 12/10/2018  
DRAWING NO: 004

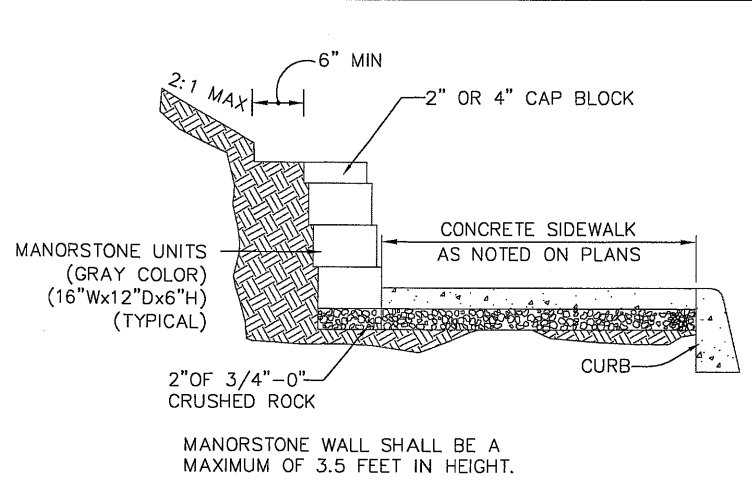

**4 BLOCK RETAINING WALL ABOVE SIDEWALK**  
N.T.S.

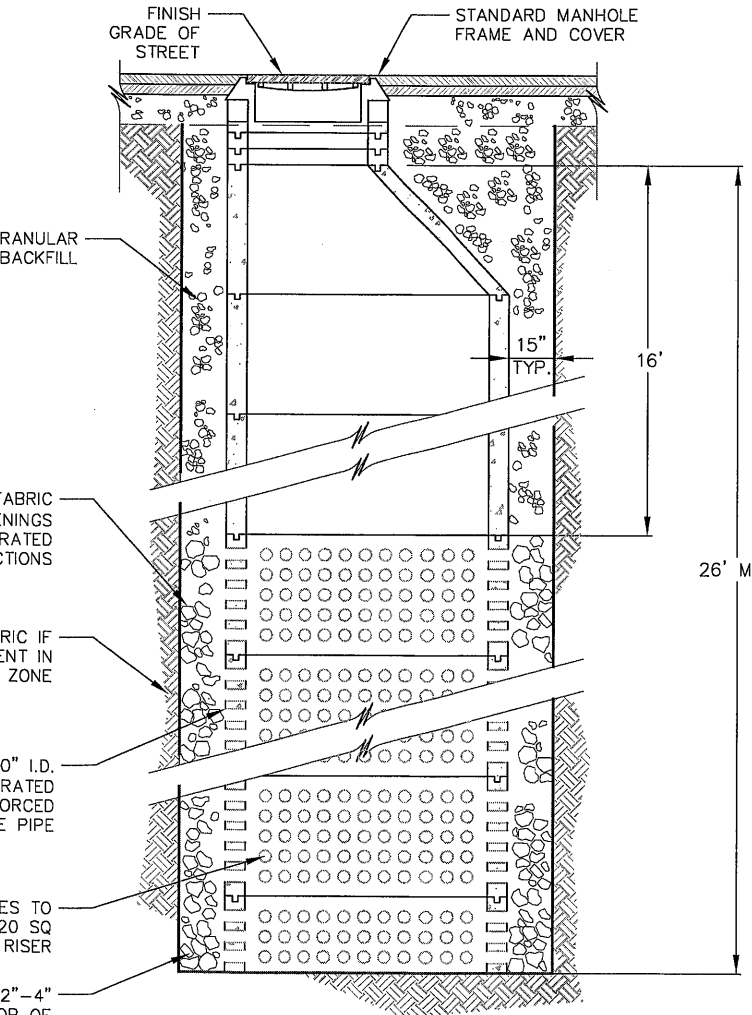

**7 STANDARD DRYWELL**  
N.T.S.

**1 FIRE HYDRANT WITH MECHANICAL JOINT CONNECTIONS**  
NOT TO SCALE

**2 WATER METER INSTALLATION & TRENCH PROFILE FOR 1" SERVICE**  
NOT TO SCALE

**3 WATER METER INSTALLATION & TRENCH PROFILE FOR 2" SERVICE**  
NOT TO SCALE

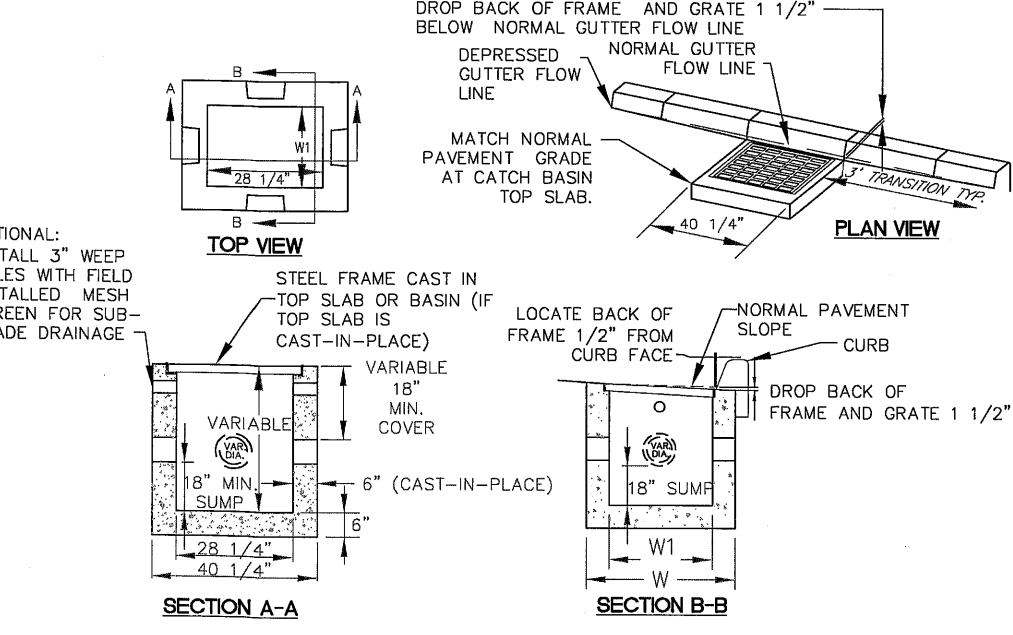

**5 TYPE G-2 CATCH BASIN WITH SUMP**  
N.T.S.

INLET TYPE	W	W	X
G-2	3'-3 3/8"	2' 3 3/8"	16 9/16"

- CATCH BASIN NOTES:**
- CONCRETE STRENGTH SHALL BE 3300 PSI.
  - PRECAST BASE WALLS SHALL BE A MINIMUM 4" THICK. CAST-IN-PLACE BASE WALLS SHALL BE 6" THICK.

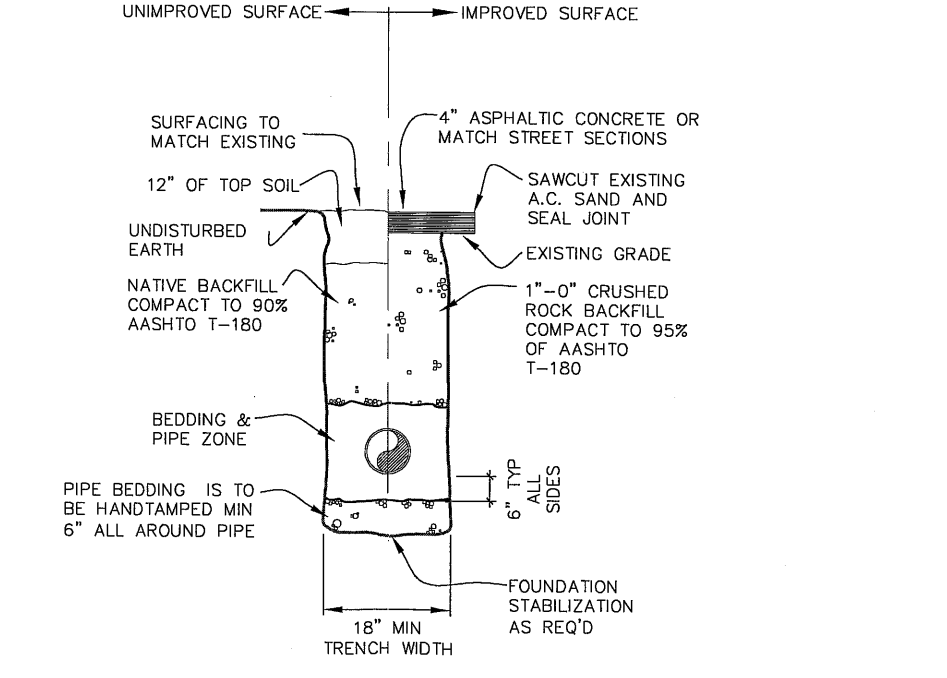

**6 TYPICAL TRENCH DETAIL**  
N.T.S.

BAR IS ONE INCH ON ORIGINAL DRAWING.  
ADJUST SCALE AS SHOWN ACCORDINGLY.

REV.	DESCRIPTION	REVISED BY	DATE

REVISIONS

**CURRAN-McLEOD, INC. CONSULTING ENGINEERS**

6655 S.W. HAMPTON ST., SUITE 210  
PORTLAND, OREGON 97223  
PHONE (503) 684-3478

**CITY OF CANBY**

**CONSTRUCTION DETAILS**

N. MAPLE STREET IMPROVEMENTS  
CLACKAMAS COUNTY, OREGON

DATE: 2/2019  
P/N: 1716  
D/R: HAI  
D/S: JVB  
C/M: 1716-C7

EXPIRES: 6/30/2019

J:\Canby\1716 - N Maple St Improvements\DWG\1716-C6-C9.dwg, 1/24/2019 11:38:59 AM, Kyocera TASKalfa 5501i KX(11x17).pc3

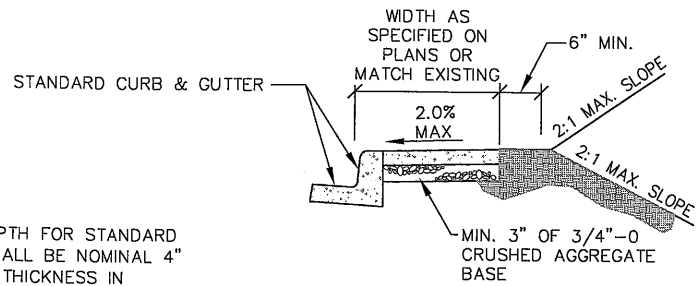

- CONCRETE DEPTH FOR STANDARD SIDEWALKS SHALL BE NOMINAL 4" MIN.; 6" MIN. THICKNESS IN DRIVEWAYS.
- TYPE 'C' CURB AT BACK OF SIDEWALK AS DIRECTED.

**TYPICAL CURB TIGHT SIDEWALK**

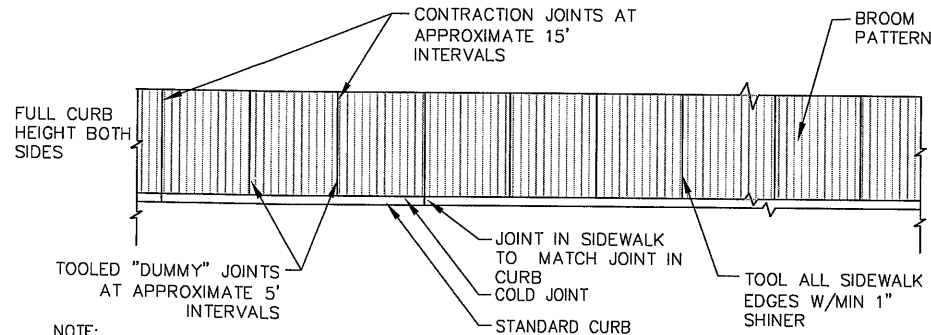

**PLAN VIEW**

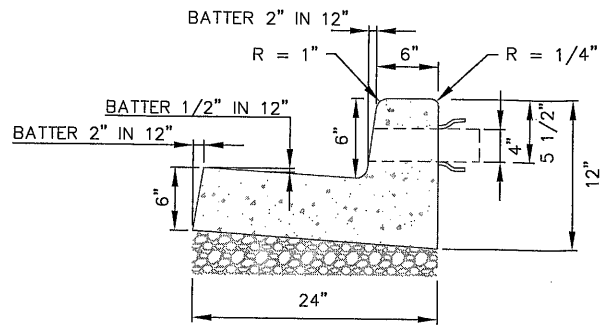

**NOTES:**

- 1) SPECIFICATIONS FOR CONCRETE AND MISCELLANEOUS MATERIALS USED IN CONSTRUCTION SHALL CONFORM TO CURRENT OREGON STANDARD SPECIFICATIONS FOR CONSTRUCTION.
- 2) CONCRETE SHALL HAVE A MINIMUM COMPRESSIVE STRENGTH OF 3300 PSI IN 28 DAYS, 2" TO 4" SLUMP.
- 3) 4" PLASTIC PIPE SHALL HAVE A BELL OR A 3" EXTENSION, FOR FUTURE HOOKUP.
- 4) EXPANSION JOINTS, MAX. 45' SPACING AND AT BEGINNING AND END OF CURVES OR AS DIRECTED.
- 5) CONTRACTION JOINTS, MAX. 15' SPACING AND AT ALL LOCATIONS AS DIRECTED.

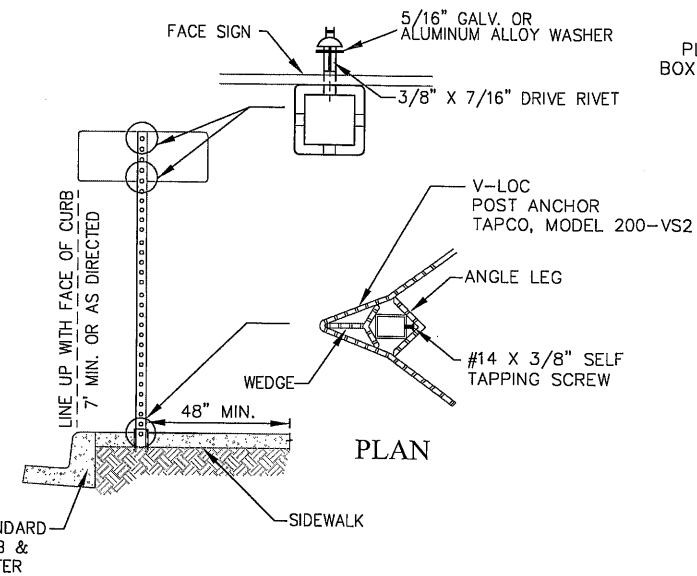

**PLAN**

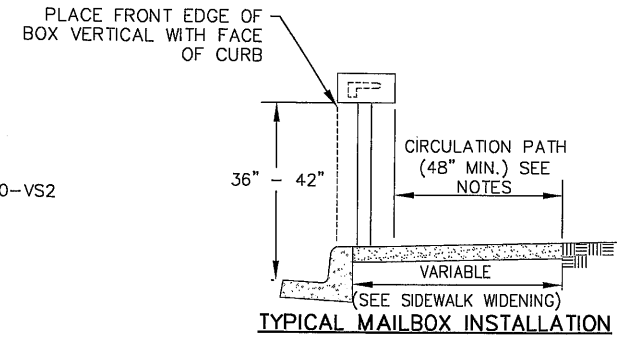

**TYPICAL MAILBOX INSTALLATION**

**NOTES:**

- 1) WHEN OBSTRUCTIONS ARE LOCATED WITHIN THE SIDEWALK THE CLEARANCE DIMENSION ARE APPLIED TO ALL DIRECTIONS.
- 2) EXCEPTIONS TO THE REQUIREMENTS IN THIS DRAWING MUST BE APPROVED BY THE ENGINEER AND MUST COMPLY WITH AMERICANS WITH DISABILITY ACT.
- 3) DEFLECT SIDEWALK AROUND AREA OF OBSTRUCTION

**1 TYPICAL SIDEWALK DETAIL**  
N.T.S.

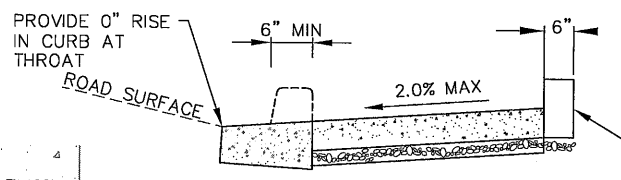

**2 STANDARD CURB AND GUTTER**  
N.T.S.

**DESIGN/FORMWORK**  
7.5% RUNNING SLOPE  
1.5% CROSS SLOPE

**CONSTRUCTED**  
8.0% MAX RUNNING SLOPE  
1.8% MAX CROSS SLOPE

**\*\*AS NECESSARY PROVIDE 1" PER FOOT TRANSITION TO MATCH INTO EXISTING (2' MIN.)**

**3 TYPICAL SIGN INSTALLATION**  
N.T.S.

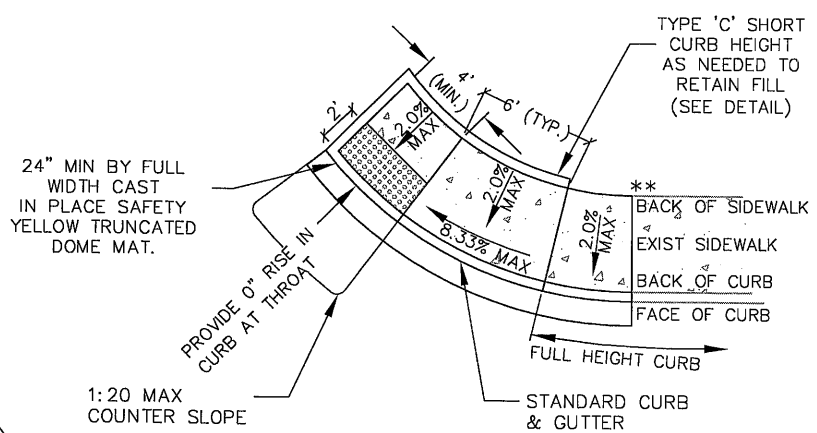

**6 ADA RAMP OPTIONS**  
N.T.S.

**4 MAILBOX PLACEMENT DETAIL**  
N.T.S.

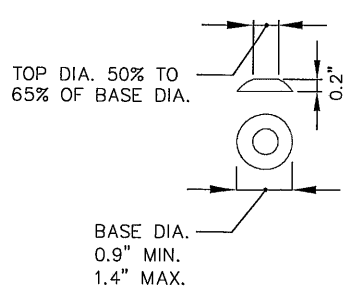

**TRUNCATED DOME DETAIL**

SEE DETAIL FOR INDIVIDUAL TRUNCATED DOME

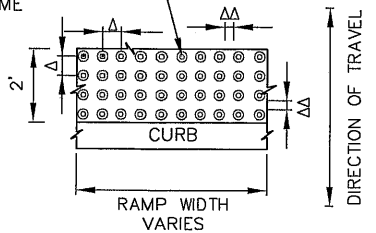

**TRUNCATED DOME PATTERN AND ORIENTATION**

Δ CTR. TO CTR. SPACING  
1.6" MIN.  
2.4" MAX.

ΔΔ BASE TO BASE SPACING 0.65" MIN.

**7 TRUNCATED DOME DETAIL**  
N.T.S.

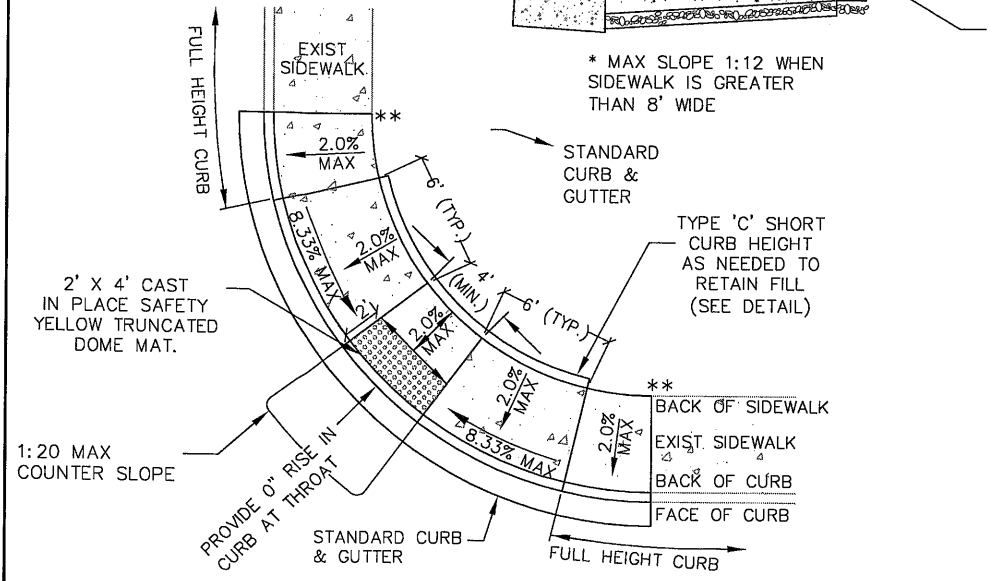

**5 ADA RAMP**  
N.T.S.

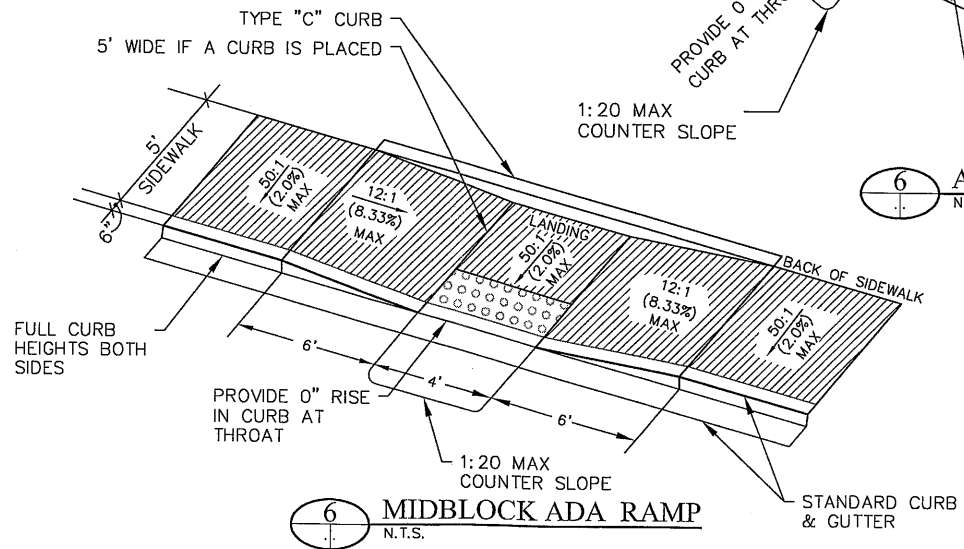

**6 MIDBLOCK ADA RAMP**  
N.T.S.

**\* ALL ADA RAMPS, IF CURB IS INSTALLED AT THE BACK OF THE RAMP, DIMENSIONS SHALL BE 4' X 5' IN THE DIRECTION OF THE RAMP TRAVEL**

BAR IS ONE INCH ON ORIGINAL DRAWING.  
ADJUST SCALE AS SHOWN ACCORDINGLY.

REV.	DESCRIPTION	REVISED BY	DATE

**REVISIONS**

**CURRAN-McLEOD, INC.**  
CONSULTING ENGINEERS

6655 S.W. HAMPTON ST., SUITE 210  
PORTLAND, OREGON 97223  
PHONE (503) 684-3478

DATE: 6/30/2019

CITY OF CANBY

**CONSTRUCTION DETAILS**

N. MAPLE STREET IMPROVEMENTS  
CLACKAMAS COUNTY, OREGON

DATE	2/2019
P/N	1716
D/S	HAL
D/S	JVB
CAD	1716-CB

**C8 OF 9**

J:\Canby\1716 - N Maple St Improvements\DWG\1716-C6-C9.dwg, 1/24/2019 11:39:33 AM, Kyocera TASKalfa 5501i KX(11x17).pc3

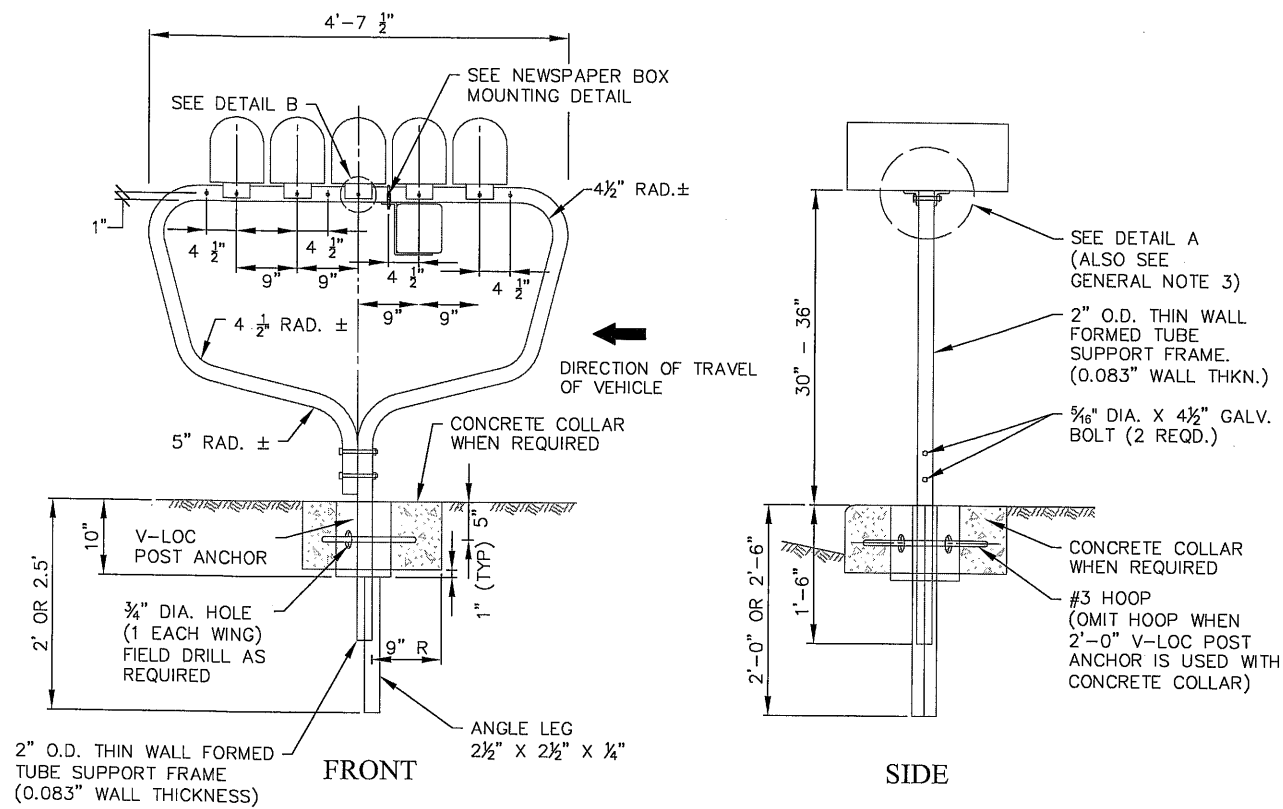

(SUPPORTS 5 STANDARD (SIZES 1 & 1 1/2") MAILBOXES OR 4 LARGE (SIZE 2) MAILBOXES)

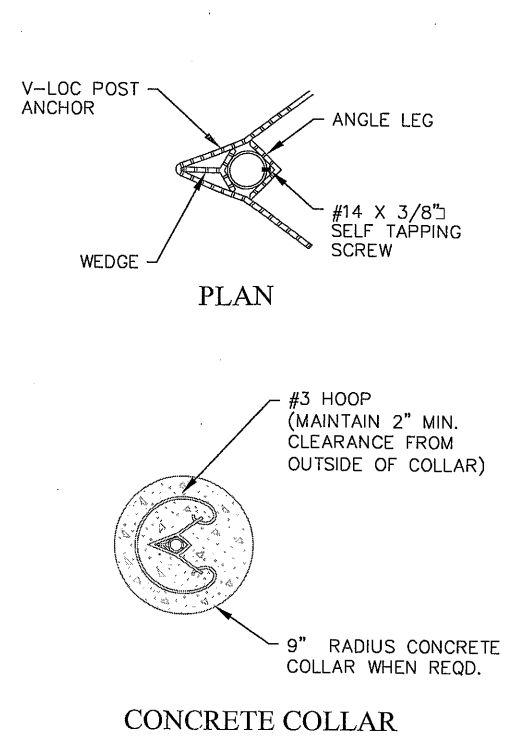

CONCRETE COLLAR

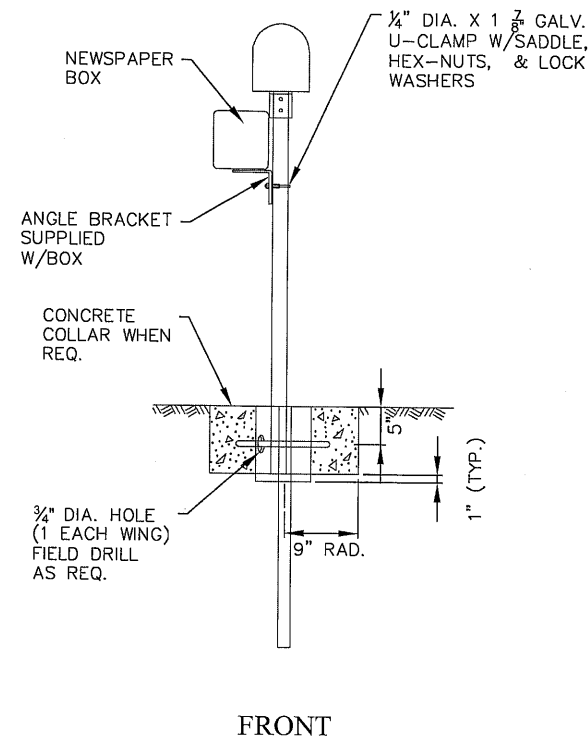

FRONT

SIDE



- GENERAL NOTES FOR ALL DETAILS:**
- ANGLE CONNECTIONS TO BE PARALLEL TO TRAFFIC FLOW FOR SIZE
  - MAILBOX MOUNTED ON SINGLE POST.
  - ALL HOLES IN THE TUBE SUPPORT FRAME ARE TO BE PREDRILLED BY THE MANUFACTURER.
  - SIZE 2 MAILBOX MOUNTED ON A MULTIPLE SUPPORT REQUIRES 2 EACH 3/8" DIA. X 5/8" GALV. BOLTS WITH LOCK WASHERS AND NUTS
  - TO ATTACH THE ADAPTOR PLATE TO THE MOUNTING BRACKET, THE UNIT WILL THEN REQUIRE 4 ANGLE CONNECTIONS TO ATTACH TO THE FORMED TUBE SUPPORT FRAME. SEE DETAIL A.
  - CONCRETE COLLAR, WHEN REQUIRED, TO BE POURED IN PLACE AFTER V-LOC POST ANCHOR HAS BEEN INSTALLED, LEVEL AND PLUMB. DO NOT EXCAVATE BELOW BOTTOM OF V-LOC POST ANCHOR. CARE SHALL BE TAKEN THAT NO CONCRETE IS PLACED WITHIN ANCHOR.
  - OTHER PROPRIETARY PRODUCTS AVAILABLE AS LISTED IN ODOT'S QPL.
  - MOUNTING HEIGHT (H) SHALL BE 42" NOMINAL, MEASURED FROM VEHICLE DRIVING SURFACE.
  - DEFLECT SIDEWALK AROUND AREA OF OBSTRUCTION
  - ALL V-LOC BASES TO BE PROVIDED BY THE CONTRACTOR

V-LOC POST ANCHOR USE CHART		
MAILBOX LOCATION	SINGLE SUPPORT (ft)	MULTIPLE SUPPORT (ft)
THROUGH NEW OR EXISTING A.C.	2'-0"	2'-0"
THROUGH WELL CONSOLIDATED MATERIAL	2'-0" *	2'-6"
THROUGH NEW ROCK SURFACING & SUBGRADE	2'-6"	2'-0" CONC. COLLAR
THROUGH NEW ROCK SURFACING & SUBGRADE, SUBJECT TO SATURATED SOIL OR FREEZE/THAW CONDITIONS.	2'-0"/ **	2'-6"/ CONC. COLLAR

\* USE 2'-6" WITH SIZE 2 MAILBOX.  
\*\* USE IF CONDITIONS ARE SEVERE.

MULTIPLE 2" X 2" X 1/8" X 4" ANGLE & SINGLE 2" X 4" X 1/8" X 4" ANGLE

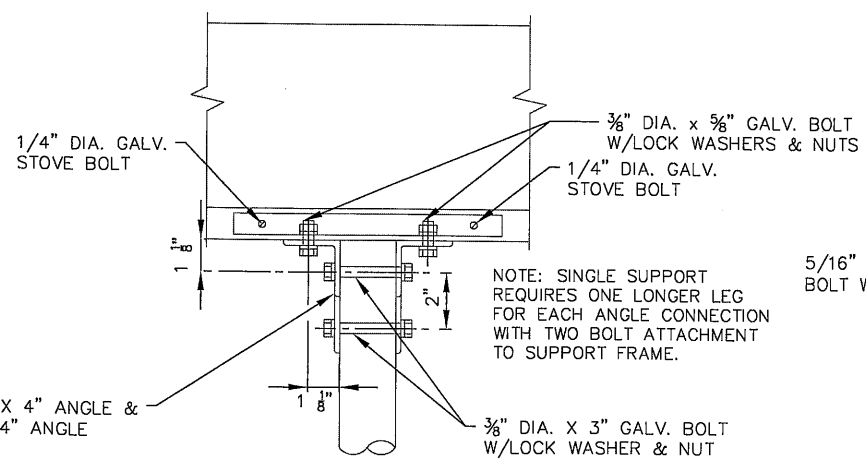

DETAIL A

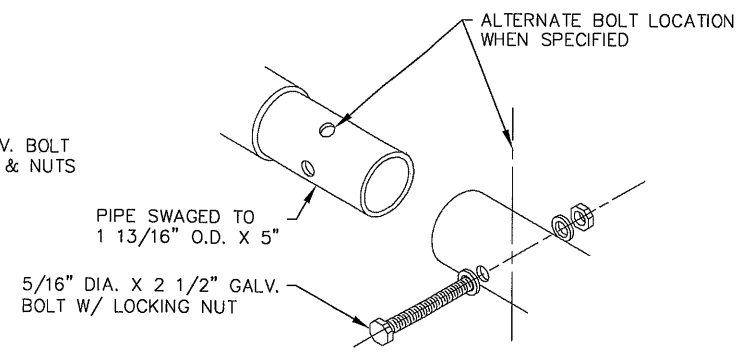

DETAIL B

BAR IS ONE INCH ON ORIGINAL DRAWING.  
ADJUST SCALE AS SHOWN ACCORDINGLY.

REV.	DESCRIPTION	REVISED BY	DATE

REVISIONS

**CURRAN-MCLEOD, INC.**  
CONSULTING ENGINEERS

6655 S.W. HAMPTON ST., SUITE 210  
PORTLAND, OREGON 97223  
PHONE (503) 684-3478

DIGITAL SIGNATURE  
HASAN ABBAS IBRAHIM  
EXPIRES: 6/30/2019

CITY OF CANBY

**CONSTRUCTION DETAILS**

N. MAPLE STREET IMPROVEMENTS  
CLACKAMAS COUNTY, OREGON

DATE	2/2019
P/N	1716
D/R	HAI
D/S	JVB
CAD	1716-C9

C9 OF 9



J:\Canby\1716 - N Maple St Improvements\DWG\1716-C2-EXISTING CONDITIONS.dwg, 1/18/2019 11:55:45 AM, DWG To PDF.pc3

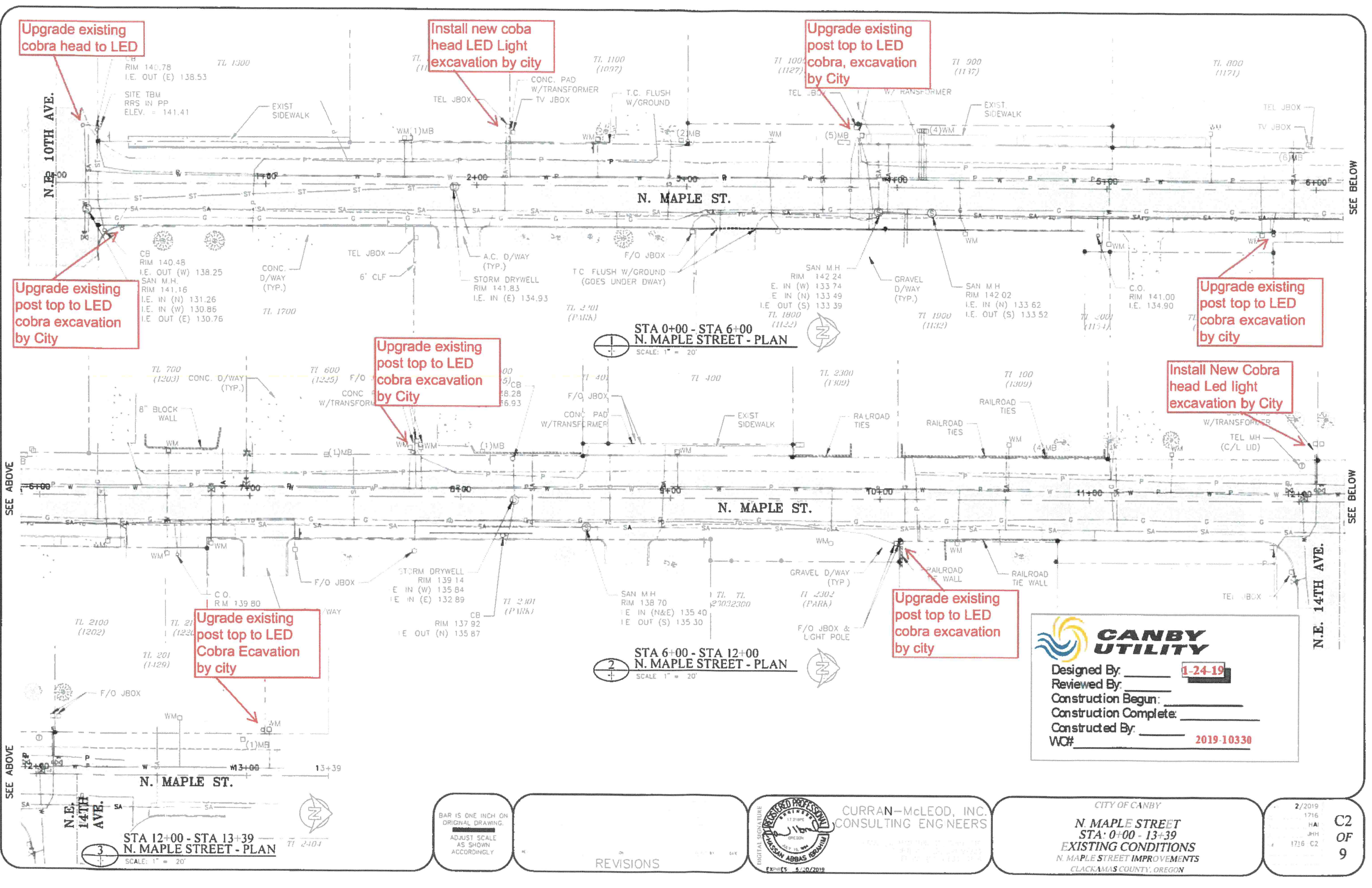

Upgrade existing cobra head to LED

Install new cobra head LED Light excavation by city

Upgrade existing post top to LED cobra, excavation by City

Upgrade existing post top to LED cobra excavation by City

Upgrade existing post top to LED cobra excavation by City

Upgrade existing post top to LED cobra excavation by city

Install New Cobra head Led light excavation by City

Upgrade existing post top to LED Cobra Excavation by city

Upgrade existing post top to LED cobra excavation by city

**CANBY UTILITY**

Designed By: \_\_\_\_\_

Reviewed By: \_\_\_\_\_ **1-24-19**

Construction Begun: \_\_\_\_\_

Construction Complete: \_\_\_\_\_

Constructed By: \_\_\_\_\_

WO# \_\_\_\_\_ **2019-10330**

STA 12+00 - STA 13+39  
N. MAPLE STREET - PLAN  
SCALE: 1" = 20'

BAR IS ONE INCH ON ORIGINAL DRAWING.  
ADJUST SCALE AS SHOWN ACCORDINGLY

REVISIONS

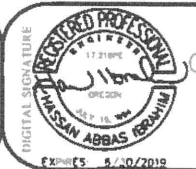

CURRAN-McLEOD, INC.  
CONSULTING ENGINEERS

CITY OF CANBY  
N. MAPLE STREET  
STA: 0+00 - 13+39  
EXISTING CONDITIONS  
N. MAPLE STREET IMPROVEMENTS  
CLACKAMAS COUNTY, OREGON

2/2019  
1716  
HAI  
JMH  
1716 C2  
C2  
OF  
9

**AFFIDAVIT OF POSTING**

**STATE OF OREGON**        )  
  )  
**County of Clackamas**    )        ss:  
  )  
**CITY OF CANBY**            )

I, Kimberly Scheafer, being first duly sworn, depose and say that I am the City Recorder for the City of Canby, Clackamas County, Oregon, a City duly incorporated under and by virtue of the laws of the State of Oregon.

That on the 6<sup>th</sup> day of March 2019 the Council for said City of Canby held a Regular City Council Meeting, at which meeting Ordinance No. 1504 was read for the first time and passed by the vote of said Council and was then and there ordered posted in at least three (3) public and conspicuous places in said City for a period of five (5) days prior to the second reading and final vote on said Ordinance, as provided in Section 2 of Chapter 8 of the Charter of the City of Canby, and

Thereafter, on the 7<sup>th</sup> day of March 2019, I personally posted said Ordinance in the following three (3) conspicuous places, all within the said City of Canby, to wit:

- 1.     Canby Civic Building Bulletin Board (Upstairs)
- 2.     Canby Civic Building Bulletin Board (Downstairs)
- 3.     Canby Post Office
- 4.     City of Canby Web Page

That since said posting on the date aforesaid, the said Ordinance will remain posted in the said three (3) public and conspicuous places continuously for the period of five (5) days and until the very 20<sup>th</sup> day of March 2019.

  
\_\_\_\_\_  
Kimberly Scheafer, MMC  
City Recorder

Subscribed and sworn to before me this 7<sup>th</sup> day of March 2019.

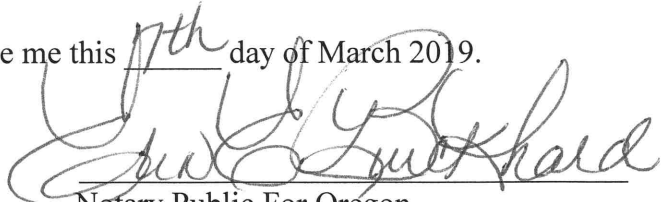
  
\_\_\_\_\_  
Notary Public For Oregon  
My Commission Expires: \_\_\_\_\_

